

**AGENDA
REGULAR SESSION
HIGHLAND CITY COUNCIL
HIGHLAND AREA SENIOR CENTER
187 WOODCREST DRIVE
MONDAY, FEBRUARY 5, 2024
6:30 PM**

NOTE: This is an in person meeting. However, anyone wishing to monitor the meeting via phone may do so by following the instructions on page 3 of this agenda.

CALL TO ORDER / ROLL CALL / PLEDGE OF ALLEGIANCE:

MINUTES:

- A. **MOTION** – Approve Minutes of January 16, 2024 Regular Session (attached)

PUBLIC FORUM:

A. Citizens' Requests and Comments:

1. Leaps of Love - 24 Hour Laps for Leaps - Special Event Application –Traci Riechmann, Representative (attached)
2. Highland Jaycees – Schweizerfest – Special Event Application – Tricia Buehne and John Meadows, Representatives (attached)
3. Business After Hours Street Closure Request – Special Event Application – Chris Ebl, Digital Artz (attached)
4. Madison County Fair Association – Special Event Application -- 2024 Speedway Events – Sue Zobrist, Track Manager (attached)

<p>Anyone wishing to address the Council on any subject may do so at this time. Please come forward to the podium and state your name. Per Ordinance No. 3299, please limit your comments to 4 minutes or less.</p>
--

B. Requests of Council:

C. Staff Reports:

NEW BUSINESS:

- A. **MOTION** – Bill #24-09/RESOLUTION Requesting Road Closure for Schweizerfest Event (attached)
- B. **MOTION** – Bill #24-10/RESOLUTION Requesting Road Closure for Schweizerfest Parade (attached)
- C. **MOTION** – Bill #24-11/RESOLUTION Approving a Construction Funding Agreement for the 6th Street Reconstruction Project (attached)
- D. **MOTION** – Bill #24-12/RESOLUTION Authorizing Approval of Expenditure of Economic Development Funds, Rebuild Illinois Funds, and Motor Fuel Tax Funds for Construction of Matter Drive, PW-05-21 (attached)
- E. **MOTION** – Bill #24-13/RESOLUTION Appropriating Funds for Motor Fuel Tax Maintenance Materials (MFT Section 25-00000-00-GM) (attached)

Continued

- F. **MOTION** – Bill #24-14/ORDINANCE Declaring Personal Property of the City Surplus and Authorizing Its Sale and/or Disposal, Specifically One Salt Spreader (attached)
- G. **MOTION** – Bill #24-15/RESOLUTION Authorizing the Sole Source Purchase of One Used 2021 Chevy $\frac{3}{4}$ Ton Truck From Steve Schmitt, Inc. for \$40,192 and Waiving Customary Bidding Procedures (attached)
- H. **MOTION** – Bill #24-16/ORDINANCE Amending City Code, Chapter 46 – Parks and Recreation, Article IV – Swimming Pool, Section 46-51, Increasing Select Rates for Day and Season Passes (attached)
- I. **MOTION** – Bill #24-17/RESOLUTION Authorizing the Mayor and/or City Manager to Apply for Park Commission Funds From Madison County, Through the Park Enhancement Program (attached)
- J. **MOTION** – Bill #24-18/ORDINANCE Declaring Personal Property of the City Surplus and Authorizing Its Sale and/or Disposal, Specifically Personal Property From City Hall (attached)
- K. **MOTION** – Bill #24-19/RESOLUTION Waiving Competitive Bidding Requirement and Approving and Authorizing the Execution of an Agreement with Indoff, on Behalf of TecCrete, for Purchase of Products, Materials, and all Labor for a Raised Floor Solution System in the City Council Chambers (attached)
- L. **MOTION** – Bill #24-20/RESOLUTION Waiving Competitive Bidding Requirement and Approving and Authorizing the Execution of a Purchase Agreement to Purchase a Palo Alto Security Device Through the State of Illinois Joint Purchasing Program as a Sole Source Purchase (attached)
- M. **MOTION** – Bill #24-21/ORDINANCE Amending Ch. 6 of the Code of Ordinances, Alcoholic Liquor, to Increase the Number of D1 Liquor Licenses to Eight, and to Increase the Number of D2 Liquor Licenses to Twelve (attached)
- N. **MOTION** – Bill #24-22/RESOLUTION Issuing a “D1” Liquor License to Gauchos Argentinian Pursuant to Chapter 6, of the Code Entitled Alcoholic Liquor (attached)
- O. **MOTION** – Bill #24-23/RESOLUTION Issuing a “D2” Liquor License to Eddies Rise N Dine Pursuant to Chapter 6, of the Code Entitled Alcoholic Liquor (attached)
- P. **MOTION** – Bill #24-24/RESOLUTION Issuing a “D2” Liquor License to Korte Meats Pursuant to Chapter 6, of the Code Entitled Alcoholic Liquor (attached)

Continued

REPORTS:

A. **MOTION** – Accepting Expenditures Reports #1259 for Jan. 13, 2024 through Feb. 2, 2024 (attached)

EXECUTIVE SESSION:

The City Council may conduct an Executive Session pursuant to the Illinois Open Meetings Act, only after citing exemptions allowing such meeting.

ADJOURNMENT:

	Anyone requiring accommodations, provided for in the Americans with Disabilities Act (ADA), to attend this public meeting, please contact Jackie Heimbürger, ADA Coordinator, by 9:00 AM on Monday, February 5, 2024.
---	---

BE ADVISED this is a public meeting conducted in accordance with Illinois state law and may be recorded for audio and video content. City reserves the right to broadcast or re-broadcast the content of this meeting at City’s sole discretion. City is not responsible for the content, video quality, or audio quality of any City meeting broadcast or re-broadcast.

Directions for Public Monitoring of Highland City Council Meetings:

The City of Highland is providing the following phone number for use by citizens to call in just before the start of this meeting:

618-882-5625

Once connected, you will be prompted to enter a conference ID number.

Conference ID #: 867900

This will allow a member of the public to hear the city council meeting.

Note: This is for audio monitoring of the meeting, only. Anyone dialing in will not be able make comments.

Anyone wishing to address the city council on any subject during the Public Forum portion of the meeting may submit their questions/comments in advance via email to lhediger@highlandil.gov or, by using the citizens’ portal on the city’s website found here: https://www.highlandil.gov/citizen_request_center_app/index.php.

Any comments received prior to 3:00 PM on the day of the meeting, will be read into the record.

CITY OF HIGHLAND



SPECIAL EVENT APPLICATION

Authorized under City Ordinance Sec. 64-3-1

PURPOSE: The City of Highland supports various community activities and festivals throughout the year. Establishing public safety and coordinating needs between the events and the city are the overall goals of this process. It is the responsibility of the specific event Sponsors to obtain, complete, and follow through the application process for city approval.

DEFINITIONS and FEES:

Special event: A "Special Event" is defined as: (1) any event, race, gathering, demonstration, or service; (2) that occurs partially or completely within the jurisdiction of the City of Highland; (3) is expected to draw crowds in excess of one hundred fifty (150) attendees; and (4) is expected to or could disrupt normal daily functions within the City of Highland including but not limited to traffic congestion and excess noise; or could create a public health/safety concern without proper precautions or prior planning. Specific examples would include (but are not limited to): The Kirchenfest, Schweizerfest, 5K runs, parades, Art in the Park, Fourth of July Festivities, Madison County Fair, etc. The City Manager will make the final determination as to whether an event qualifies. This will be based upon the totality of the circumstances presented.

Ongoing Event: An "Ongoing Event" is defined as any event that occurs partially or completely within the jurisdiction of the City of Highland consecutively for a period of time that exceeds more than two times monthly. Specific examples would include (but are not limited to): automobile races, re-occurring sporting events not affiliated with HUSD5, weekly music festivals, and other weekly reoccurring events). The City Manager will make the final determination as to whether an event qualifies. This will be based on the totality of the circumstances presented and will require approval depending on requests of individual departments by their Directors.

Highland Public Safety Fees for Special Events:

Police Department: The Highland Police Department will be paid at a rate of \$50.00 per officer per race event (runs or bicycle) when required for traffic control. The Highland Police Department will be paid at a rate of \$100.00 per officer per day, per event when officers are requested outside of the normal day-to-day operation.

Emergency Medical Services Department: No additional fees for Special Events unless organizers require service outside of the normal day-to-day operation.

Fire Department:

No additional fees for Special Events unless organizers require service outside of the normal day-to-day operation.

Highland Public Safety Fees for On-Going Events:

Police Department: The Highland Police Department will be reimbursed at a rate of 1 ½ times the rate of the officer working the ongoing event. Scheduling will be arranged and agreed upon by the organizer, the Chief of Police or his/her designee.

Emergency Medical Services Department:

The Highland Emergency Medical Services Department will be paid at a rate of \$75.00 per half hour when requested for an ongoing event. Scheduling will be arranged and agreed upon by the organizer and the EMS Chief or his/her designee. The following are details of provided additional service:

- Two crew members to provide medical services throughout the event.
- Fuel charges consistent with leaded mile rate.
- Medical supplies used during the event
- Wear and tear on the truck for idle state

Trucks must remain in an idle state throughout the course of the event for patient comfort and to maintain moderate temperatures for medications and I.V. fluids. Scheduling will be arranged and agreed upon by the organizer and the Emergency Services Chief or his/her designee.

Fire Department:

The Highland Fire Department will be reimbursed at a rate of \$21.00 per firefighter per hour working the ongoing event. Scheduling will be arranged and agreed upon by the organizer and the Fire Chief or his/her designee.

PROCEDURE:

1. All Requests will be directed to Highland City Hall, to the attention of the Director of Support Services.
2. Applications will be available at Highland City Hall, Monday-Friday, 8:00 am to 5:00 pm or online through the City's web site.
3. Applications will be completed by the Event Sponsor and submitted at least 60 days prior to the event. The application must be signed by the Event Sponsor Responsible Party. Incomplete applications will not be accepted. If an application is accepted and later determined to be incomplete, the applicant will be notified by the Director of Support Services. Failure to provide information will result in denial of application.
4. The Director of Support Services will forward the application to all city departments that have responsibilities relating to the event. If necessary, a committee meeting involving the event Sponsor and city stakeholders may take place to clarify questions, determine specific needs, and address concerns.
5. The event Sponsor is required to obtain final approval for the special event from the City Manager. The City Council may announce the special event to the public at a scheduled Council meeting.

CITY OF HIGHLAND-SPECIAL EVENT APPLICATION

Name of Event: 24 Hour Laps for Leaps

Type of Event: Festival Race Other Fundraiser Service Parade
 Other (please specify): _____

Description of Event: Endurance race with street cars that will compete for 24 hours to accumulate the most laps

Location of Event: Highland Speedway

Sponsoring Organization/Individual: Leaps of Love

Event Responsible Party: Traci Riechmann
Address: 1005 B Broadway, Highland, IL 62249
Phone(s): 618-410-7212
Email: traci@leapsoflove.org

Date(s) of Set-up: 09-22-24

Event Date(s) / Times: 09-27-24 4pm – 09-28-24 10pm

Date(s) of Tear-down: 09-29-24

Expected Attendance: 1000

Alcohol License Required: Yes No (Helvetia Sharpshooters)
If yes, application submitted: Yes No

Sound Amplification System utilized: Yes No (*Only available for the Square*)
If yes, hours of operation: _____

Funding request of the Council: Yes No
Amount requested: \$ _____
Purpose for Funding: _____

Street Dept: Signage, Barricades, Street Closures (Specify): -

Electric Dept: Electrical Service, Lighting (Specify):
Possible (depending on the improvements at the track this race season)

Public Safety: If anything needed in addition to below (Specify):

HCS Services: Wi-Fi or other technological needs (Specify):

Other City Services: Restrooms, City Officials, Refuse Dumpsters-Charges Apply (Specify):

I rented a large dumpster through the city in 2023 and will again in 2024

Signs: Per the City of Highland’s Municipal Code, signs are disallowed on public right-of-way. If you wish to display signs on right-of-way, please indicate the requested location of signs: Bank of Hillsboro round-a-bout

If approval is granted, signs must not be displayed within roundabouts or within any area that is difficult for vehicles to see around and creates a traffic safety issue. All signs within right-of-way must be displayed no more than two weeks prior to the event unless specifically requested and removed within two days after the event.

Specify Special Event or Ongoing Event (as defined above) 24 Hr. Laps for Leaps

Specify Route Option # _____ (listed on attached Maps)

Route must be approved by Public Safety director before application can be brought to council for approval.

Check the boxes below for what Services apply and number of each service needed

(See Page 1&2 and Race Option/Maps provided for more information)

- Police** – Number of officers needed for Event _____
- EMS** – Number of Emergency Medics needed for Event 2
- Fire** – Number of Firefighters needed for Event _____

Application Checklist (Attachments):

- Council Meeting Scheduled for approval
- Certificate of Insurance: (Must attached for approval)
 - Must be General liability
 - \$1 Million per occurrence/\$2 million aggregate
 - City named as “additional insured” If Event is on city property.
- Site Plan Rendering
- Evacuation Plan
- Fire Plan

Parking Plan

City Services Requested: – Please attach additional documents such as maps, flyers or any other detailed information.

Travis J. Beckmann
Event Sponsor Responsible Party

1-12-24
Date

City Manager

Date



CERTIFICATE OF LIABILITY INSURANCE

DATE (MM/DD/YYYY)

1/18/2024

THIS CERTIFICATE IS ISSUED AS A MATTER OF INFORMATION ONLY AND CONFERS NO RIGHTS UPON THE CERTIFICATE HOLDER. THIS CERTIFICATE DOES NOT AFFIRMATIVELY OR NEGATIVELY AMEND, EXTEND OR ALTER THE COVERAGE AFFORDED BY THE POLICIES BELOW. THIS CERTIFICATE OF INSURANCE DOES NOT CONSTITUTE A CONTRACT BETWEEN THE ISSUING INSURER(S), AUTHORIZED REPRESENTATIVE OR PRODUCER, AND THE CERTIFICATE HOLDER.

IMPORTANT: If the certificate holder is an ADDITIONAL INSURED, the policy(ies) must have ADDITIONAL INSURED provisions or be endorsed. If SUBROGATION IS WAIVED, subject to the terms and conditions of the policy, certain policies may require an endorsement. A statement on this certificate does not confer rights to the certificate holder in lieu of such endorsement(s).

PRODUCER Church Asset Management, Inc. 1500 Wall Street Saint Charles MO 63303 License#: L100460 LEAPOFL-01	CONTACT NAME: DeeDee Corsnitz PHONE (A/C, No, Ext): 800-200-7257 E-MAIL ADDRESS: dcorsnitz@LTCAM.com	FAX (A/C, No): 866-608-0600	
	INSURER(S) AFFORDING COVERAGE		NAIC #
INSURED Leaps of Love 1005 Broadway Highland IL 62249	INSURER A: GuideOne Mutual Insurance Company		15032
	INSURER B:		
	INSURER C:		
	INSURER D:		
	INSURER E:		
	INSURER F:		

COVERAGES **CERTIFICATE NUMBER:** 2020361744 **REVISION NUMBER:**

THIS IS TO CERTIFY THAT THE POLICIES OF INSURANCE LISTED BELOW HAVE BEEN ISSUED TO THE INSURED NAMED ABOVE FOR THE POLICY PERIOD INDICATED. NOTWITHSTANDING ANY REQUIREMENT, TERM OR CONDITION OF ANY CONTRACT OR OTHER DOCUMENT WITH RESPECT TO WHICH THIS CERTIFICATE MAY BE ISSUED OR MAY PERTAIN, THE INSURANCE AFFORDED BY THE POLICIES DESCRIBED HEREIN IS SUBJECT TO ALL THE TERMS, EXCLUSIONS AND CONDITIONS OF SUCH POLICIES. LIMITS SHOWN MAY HAVE BEEN REDUCED BY PAID CLAIMS.

INSR LTR	TYPE OF INSURANCE	ADDL INSD	SUBR WVD	POLICY NUMBER	POLICY EFF (MM/DD/YYYY)	POLICY EXP (MM/DD/YYYY)	LIMITS
A	<input checked="" type="checkbox"/> COMMERCIAL GENERAL LIABILITY <input type="checkbox"/> CLAIMS-MADE <input checked="" type="checkbox"/> OCCUR GEN'L AGGREGATE LIMIT APPLIES PER: <input checked="" type="checkbox"/> POLICY <input type="checkbox"/> PRO-JECT <input type="checkbox"/> LOC OTHER:	N	N	010019963	8/31/2023	8/31/2024	EACH OCCURRENCE \$ 1,000,000 DAMAGE TO RENTED PREMISES (Ea occurrence) \$ 1,000,000 MED EXP (Any one person) \$ 20,000 PERSONAL & ADV INJURY \$ 1,000,000 GENERAL AGGREGATE \$ 3,000,000 PRODUCTS - COMP/OP AGG \$ 3,000,000 \$
A	<input type="checkbox"/> ANY AUTO <input type="checkbox"/> OWNED AUTOS ONLY <input type="checkbox"/> SCHEDULED AUTOS <input checked="" type="checkbox"/> HIRED AUTOS ONLY <input checked="" type="checkbox"/> NON-OWNED AUTOS ONLY	N	N	001803664	8/31/2023	8/31/2024	COMBINED SINGLE LIMIT (Ea accident) \$ 1,000,000 BODILY INJURY (Per person) \$ BODILY INJURY (Per accident) \$ PROPERTY DAMAGE (Per accident) \$ \$
	<input type="checkbox"/> UMBRELLA LIAB <input type="checkbox"/> OCCUR <input type="checkbox"/> EXCESS LIAB <input type="checkbox"/> CLAIMS-MADE DED RETENTION \$						EACH OCCURRENCE \$ AGGREGATE \$ \$
	WORKERS COMPENSATION AND EMPLOYERS' LIABILITY ANY PROPRIETOR/PARTNER/EXECUTIVE OFFICER/MEMBER EXCLUDED? (Mandatory in NH) If yes, describe under DESCRIPTION OF OPERATIONS below	Y/N	N/A				<input type="checkbox"/> PER STATUTE <input type="checkbox"/> OTHER E.L. EACH ACCIDENT \$ E.L. DISEASE - EA EMPLOYEE \$ E.L. DISEASE - POLICY LIMIT \$

DESCRIPTION OF OPERATIONS / LOCATIONS / VEHICLES (ACORD 101, Additional Remarks Schedule, may be attached if more space is required)
 Confirmation of insurance.

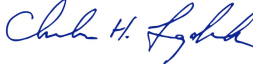
CERTIFICATE HOLDER City Of Highland P.O. Box 218 1115 Broadway Highland IL 62249	CANCELLATION SHOULD ANY OF THE ABOVE DESCRIBED POLICIES BE CANCELLED BEFORE THE EXPIRATION DATE THEREOF, NOTICE WILL BE DELIVERED IN ACCORDANCE WITH THE POLICY PROVISIONS.
	AUTHORIZED REPRESENTATIVE 

© 1988-2015 ACORD CORPORATION. All rights reserved.

CITY OF HIGHLAND



SPECIAL EVENT APPLICATION

Authorized under City Ordinance Sec. 64-3-1

PURPOSE: The City of Highland supports various community activities and festivals throughout the year. Establishing public safety and coordinating needs between the events and the city are the overall goals of this process. It is the responsibility of the specific event Sponsors to obtain, complete, and follow through the application process for city approval.

DEFINITIONS and FEES:

Special event: A "Special Event" is defined as: (1) any event, race, gathering, demonstration, or service; (2) that occurs partially or completely within the jurisdiction of the City of Highland; (3) is expected to draw crowds in excess of one hundred fifty (150) attendees; and (4) is expected to or could disrupt normal daily functions within the City of Highland including but not limited to traffic congestion and excess noise; or could create a public health/safety concern without proper precautions or prior planning. Specific examples would include (but are not limited to): The Kirchenfest, Schweizerfest, 5K runs, parades, Art in the Park, Fourth of July Festivities, Madison County Fair, etc. The City Manager will make the final determination as to whether an event qualifies. This will be based upon the totality of the circumstances presented.

Ongoing Event: An "Ongoing Event" is defined as any event that occurs partially or completely within the jurisdiction of the City of Highland consecutively for a period of time that exceeds more than two times monthly. Specific examples would include (but are not limited to): automobile races, re-occurring sporting events not affiliated with HUSD5, weekly music festivals, and other weekly reoccurring events). The City Manager will make the final determination as to whether an event qualifies. This will be based on the totality of the circumstances presented and will require approval depending on requests of individual departments by their Directors.

Highland Public Safety Fees for Special Events:

Police Department: The Highland Police Department will be paid at a rate of \$50.00 per officer per race event (runs or bicycle) when required for traffic control. The Highland Police Department will be paid at a rate of \$100.00 per officer per day, per event when officers are requested outside of the normal day-to-day operation.

Emergency Medical Services Department: No additional fees for Special Events unless organizers require service outside of the normal day-to-day operation.

Fire Department:

No additional fees for Special Events unless organizers require service outside of the normal day-to-day operation.

Highland Public Safety Fees for On-Going Events:

Police Department: The Highland Police Department will be reimbursed at a rate of 1 ½ times the rate of the officer working the ongoing event. Scheduling will be arranged and agreed upon by the organizer, the Chief of Police or his/her designee.

Emergency Medical Services Department:

The Highland Emergency Medical Services Department will be paid at a rate of \$75.00 per half hour when requested for an ongoing event. Scheduling will be arranged and agreed upon by the organizer and the EMS Chief or his/her designee. The following are details of provided additional service:

- Two crew members to provide medical services throughout the event.
- Fuel charges consistent with leaded mile rate.
- Medical supplies used during the event
- Wear and tear on the truck for idle state

Trucks must remain in an idle state throughout the course of the event for patient comfort and to maintain moderate temperatures for medications and I.V. fluids. Scheduling will be arranged and agreed upon by the organizer and the Emergency Services Chief or his/her designee.

Fire Department:

The Highland Fire Department will be reimbursed at a rate of \$21.00 per firefighter per hour working the ongoing event. Scheduling will be arranged and agreed upon by the organizer and the Fire Chief or his/her designee.

PROCEDURE:

1. All Requests will be directed to Highland City Hall, to the attention of the Director of Support Services.
2. Applications will be available at Highland City Hall, Monday-Friday, 8:00 am to 5:00 pm or online through the City's web site.
3. Applications will be completed by the Event Sponsor and submitted at least 60 days prior to the event. The application must be signed by the Event Sponsor Responsible Party. Incomplete applications will not be accepted. If an application is accepted and later determined to be incomplete, the applicant will be notified by the Director of Support Services. Failure to provide information will result in denial of application.
4. The Director of Support Services will forward the application to all city departments that have responsibilities relating to the event. If necessary, a committee meeting involving the event Sponsor and city stakeholders may take place to clarify questions, determine specific needs, and address concerns.
5. The event Sponsor is required to obtain final approval for the special event from the City Manager. The City Council may announce the special event to the public at a scheduled Council meeting.

CITY OF HIGHLAND-SPECIAL EVENT APPLICATION

Name of Event: Highland Juicee Schweizerfest

Type of Event: Festival Race Other Fundraiser Service Parade
 Other (please specify): _____

Description of Event: Annual festival

Location of Event: Square

Sponsoring Organization/Individual: Highland Juicees

Event Responsible Party: Highland Juicees
Address: PO Box 521, Highland, IL 62249
Phone(s): 618-977-4306
Email: tbuehne@firstmid.com

Date(s) of Set-up: 6/3-6/7

Event Date(s) / Times: 6/7 5pm - 6/9

Date(s) of Tear-down: 6/9 - 6/10

Expected Attendance: 10,000 - 15,000

Alcohol License Required: Yes No
If yes, application submitted: Yes No

Sound Amplification System utilized: Yes No (Only available for the Square)
If yes, hours of operation: _____

Funding request of the Council: Yes No
Amount requested: \$ 5,000
Purpose for Funding: marketing

Street Dept: Signage, Barricades, Street Closures (Specify):
Yes, like every year for normal with the addition of the extra block of Broadway from Laurel to Walnut

Electric Dept: Electrical Service, Lighting (Specify):
Yes, like every year

Public Safety: If anything needed in addition to below (Specify):

Yes, like every year

HCS Services: Wi-Fi or other technological needs (Specify):

Other City Services: Restrooms, City Officials, Refuse Dumpsters-Charges Apply (Specify):

Yes, like every year

Signs: Per the City of Highland’s Municipal Code, signs are disallowed on public right-of-way. If you wish to display signs on right-of-way, please indicate the requested location of signs:

If approval is granted, signs must not be displayed within roundabouts or within any area that is difficult for vehicles to see around and creates a traffic safety issue. All signs within right-of-way must be displayed no more than two weeks prior to the event unless specifically requested and removed within two days after the event.

Specify Special Event or Ongoing Event (as defined above) ongoing

Specify Route Option # _____ (listed on attached Maps)
Route must be approved by Public Safety director before application can be brought to council for approval.

Check the boxes below for what Services apply and number of each service needed
(See Page 1&2 and Race Option/Maps provided for more information)

- Police** – Number of officers needed for Event what you request we will use
- EMS** – Number of Emergency Medics needed for Event what you request we will use
- Fire** – Number of Firefighters needed for Event what you request we will use

Application Checklist (Attachments):

- Council Meeting Scheduled for approval
- Certificate of Insurance: (Must attached for approval)
 - o Must be General liability
 - o \$1 Million per occurrence/\$2 million aggregate
 - o City named as “additional insured” If Event is on city property.
- Site Plan Rendering
- Evacuation Plan
- Fire Plan
- Parking Plan

City Services Requested: – Please attach additional documents such as maps, flyers or any other detailed information.

Chiaia Ruyhne
Event Sponsor Responsible Party

01/23/2024
Date

City Manager

Date

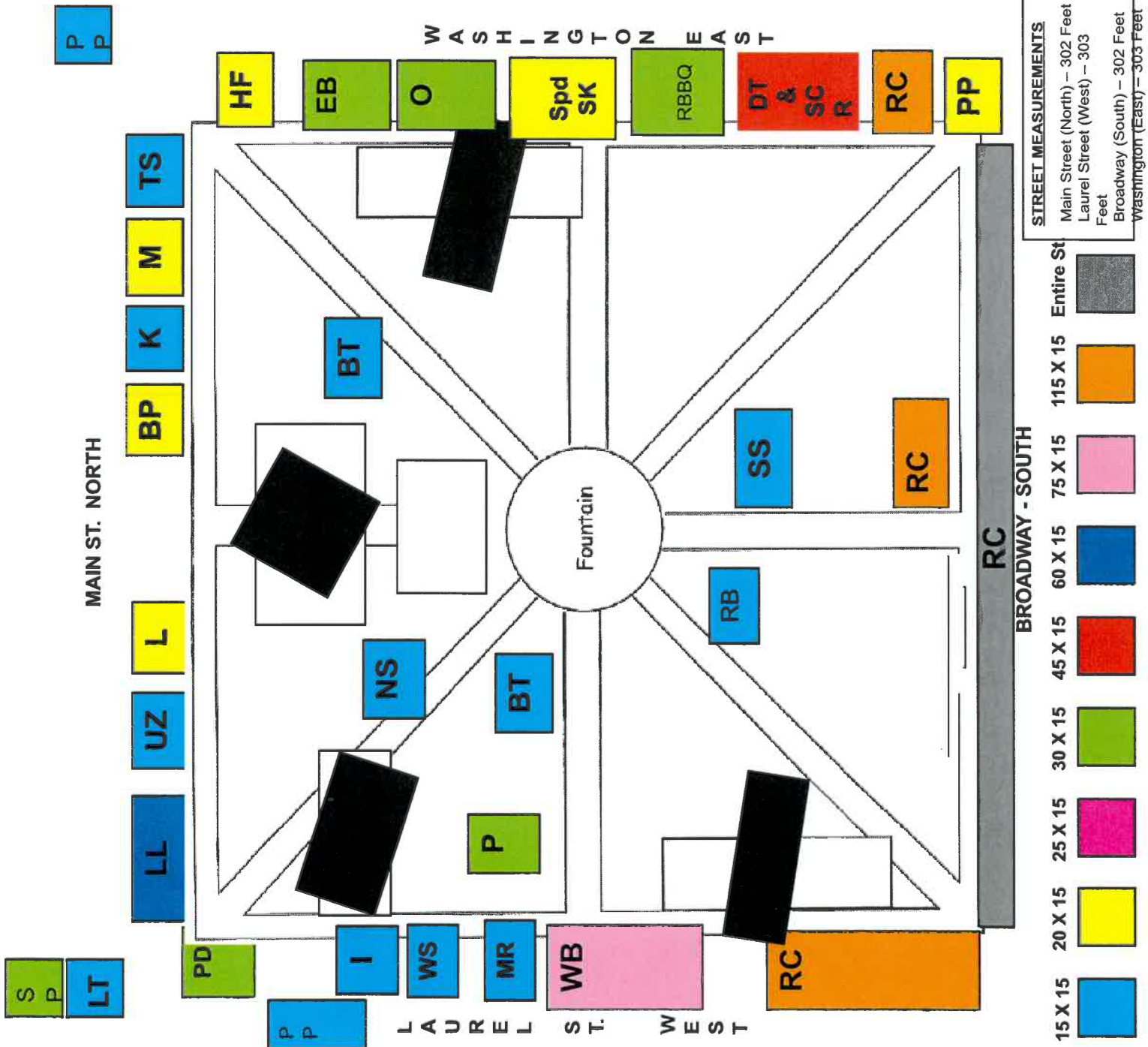

KEY

Outer Ring starting at West Beer going Clockwise

- WB - Highland Jaycees (West Beer) (Elec 110)
- MR - Highland Jaycees Margarita Stand (110)
- WS - Jaycees Welcome Stand (Elec 110)
- I - Twice the Ice (Elec 110)
- PD - Police Department (Elec 110)
- LL - Linenfesler Concessions (Elec 220)
- UZ - Uncle Zorba's (Elec 110)
- L - Highland Lions Club (Elec 110)
- BP - Highland Band Parents (Elec 110)
- K - Kettle Korn Company (Elec 110)
- M - Highland Moose Lodge (Elec 110)
- TS - Tropical Sno (Elec 110)
- HF - Heartland Food Service (Elec 220)
- EB - Highland Jaycees (East Beer) (Elec 110)
- O - Highland Optimist (Elec 220)
- SPD SK - Spud Shack - (Elec 110)
- RBBQ - Randy's - (Elec 110)
- RC - Ride Company still looking for replacement

Inside Square Grounds

- P - Jaycees Poker Stand (Elec 110)
- BT - Beer Tickets West (Elec 110)
- NS - North Soda (Elec 110)
- BT - Beer Tickets East (Elec 110)
- SS - South Soda (Elec 110)
- RB - Ron Beck (Elec 110)

Additional Vendors

- LT - Linenfesler Truck
- SP - Soda Truck
- PP - Whiteside Sanitation
- DT - Dunk Tank and Inflatable Soccer

STREET MEASUREMENTS

- Main Street (North) - 302 Feet
- Laurel Street (West) - 303 Feet
- Broadway (South) - 302 Feet
- Washington (East) - 303 Feet

BROADWAY - SOUTH

- 15 X 15
- 20 X 15
- 25 X 15
- 30 X 15
- 45 X 15
- 60 X 15
- 75 X 15
- 115 X 15
- Entire St



Schweizerfest Emergency Action Plan

GENERAL

The Schweizerfest will be held June 7 – 9th, 2023 on the Highland City Square, Highland, IL.

PURPOSE

- This emergency action plan predetermines actions to take before and during the “Schweizerfest” (hereinafter referred to as the event) in response to an emergency or otherwise, hazardous condition. These actions will be taken by organizers, management, personnel, and attendees. These actions represent those required prior to the event in preparation for and those required during an emergency.
- Flexibility must be exercised when implementing this plan because of the wide variety of potential hazards that exist for this event. These hazards include, but are not limited to, Medical Emergencies, Severe Weather, Fire, or situations where Law Enforcement is required.

ASSUMPTIONS

The possibility of an occurrence of an emergency is present at this event. The types of emergencies possible are various and could require the response of Emergency Management, Emergency Medical Services, Fire and Police.

BASIC PLAN

- EAP Event Representative
 - o The EAP event representative will be identified as the point of contact for all communications regarding the event. This person is identified as Adam Vosholler (2023 Schweizerfest Chairman).
- Emergency Notification

- o In the event of an emergency, notification of the emergency will be through the use of 911. The caller should have the following information available: nature of emergency, location, and contact person with callback number.

- o We will have HFD/EMS Fire Chief's contact information.

- o We will have on-site HPD as scheduled.

- Severe Weather

- o Weather forecasts and current conditions will be monitored through the National Weather Service's Weather Forecast Website.

- o Before the event – If severe weather is predicted prior to the event, the EAP event representative will evaluate the conditions and determine if the event will remain scheduled. The EAP event representative or his/her designee will be identified as such and will be responsible to monitor the weather conditions before and during the event.

- o During the event – If severe weather occurs during the event, the EAP event representative or his/her designee will make notification to those attending the event that a hazardous weather condition exists and direct them to shelter.

- o There are very limited provisions for sheltering participants in the event of severe weather.

- o This event will follow the 30-30 Rule for lightning. If lightning is observed and thunder is heard within 30 seconds, the event will be delayed until 30 minutes have past since thunder was last heard.

- Fire

- o No specific hazard has been identified as an increased risk of fire at this event.

- o All event staff will be instructed on the safe use of Portable Fire Extinguishers.

- o Should an incident occur that requires the Fire Department, 911 will be utilized to request this resource. The caller should have the following information available to the 911 operator: nature of emergency, location, and contact person with callback number.

- Medical Emergencies

- o As with any outdoor event, there is potential for injury to the participants. The

types of injuries are various and include those that are heat related, Medical, as well as traumatic injuries.

- o There are provisions for on-site Emergency Medical Services at this event.

- o Should an incident occur that requires Emergency Medical Services, the EAP event representative or his/her designee will be contacted to request this resource. The caller will have the following information available to 911 dispatch, the nature of emergency, precise location, and contact person with callback number.

- Law Enforcement

- o The need for constant Law Enforcement presence at this event has been identified.

- o Should an incident occur that requires Law Enforcement, the on-site HPD officer will be contacted to request this resource. The caller will have the following information available to the on-site HPD officer, the nature of emergency, precise location, and contact person with callback number.

- Emergency Vehicle Access

- o Access for Emergency Vehicles will be maintained at all times.

- o Fire lanes and fire hydrants will not be obstructed.

- o Participants and spectators will be directed to park in approved areas and not to obstruct protective features, sidewalks or public thoroughways.

- o Crowd control will be managed by on site HPD.

Contact Information:

Primary Contact	Secondary Contact	Emergency
Jon Meadows (618) 791-3721	Zach Resmann (618) 792-5922	911



Schweizerfest 2024
June 7th, 8th, and 9th
Parking Plan



Parking is available at these designated lots in the yellow boxes. Public parking is also available in further lots and additional side street options.

Schweizerfest Parade Route

7th St

NAPA Auto Parts -
McKay Auto Parts

Oberbeck Grain

7th St

8th St
Mulberry St

8th St
First Congregational Church

Highland Police Department

Highland Area Christian Services

John Wildi Masonic Temple

Rosenthal Optometric

9th St
Mulberry St

Klaus Automotive & Diesel Services

It's Party Time

Marx Brothers Lounge
Voegele Photography Studio

Weinheimer Community Center

Main St

Klaus Automotive & Diesel Services

Michael's Restaurant

Don Ole Mexican Restaurant

Wedding Belle Bridal Shoppe

Broadway Bar & Grill

Enterprise Rent-A-Car

Highland's 110 Buy

Highland Community Schools

Nails Pro

Dimaggio's Italian

Shell

U.S. Bank Branch

Nevco

Fastenal

Jerry's Tackle and Guns

Laurel St

Pine St

12th St

Shopper's Review

Water Tower Park

Water Tower Park



5k map



CERTIFICATE OF LIABILITY INSURANCE

OP ID: EK

DATE (MM/DD/YYYY)

01/30/2024

THIS CERTIFICATE IS ISSUED AS A MATTER OF INFORMATION ONLY AND CONFERS NO RIGHTS UPON THE CERTIFICATE HOLDER. THIS CERTIFICATE DOES NOT AFFIRMATIVELY OR NEGATIVELY AMEND, EXTEND OR ALTER THE COVERAGE AFFORDED BY THE POLICIES BELOW. THIS CERTIFICATE OF INSURANCE DOES NOT CONSTITUTE A CONTRACT BETWEEN THE ISSUING INSURER(S), AUTHORIZED REPRESENTATIVE OR PRODUCER, AND THE CERTIFICATE HOLDER.

IMPORTANT: If the certificate holder is an ADDITIONAL INSURED, the policy(ies) must be endorsed. If SUBROGATION IS WAIVED, subject to the terms and conditions of the policy, certain policies may require an endorsement. A statement on this certificate does not confer rights to the certificate holder in lieu of such endorsement(s).

PRODUCER Zimmerman Insurance Agency 1719 Troy Road, PO Box 508 Edwardsville, IL 62025 Eric Kolesa		CONTACT NAME: PHONE (A/C, No, Ext): _____ FAX (A/C, No): _____ E-MAIL ADDRESS: _____ PRODUCER CUSTOMER ID #: HIGHL-1	
INSURED Highland Jaycees P O Box 521 Highland, IL 62249		INSURER(S) AFFORDING COVERAGE INSURER A : Erie Insurance Group NAIC # 26271 INSURER B : _____ INSURER C : _____ INSURER D : _____ INSURER E : _____ INSURER F : _____	

COVERAGES**CERTIFICATE NUMBER:****REVISION NUMBER:**

THIS IS TO CERTIFY THAT THE POLICIES OF INSURANCE LISTED BELOW HAVE BEEN ISSUED TO THE INSURED NAMED ABOVE FOR THE POLICY PERIOD INDICATED. NOTWITHSTANDING ANY REQUIREMENT, TERM OR CONDITION OF ANY CONTRACT OR OTHER DOCUMENT WITH RESPECT TO WHICH THIS CERTIFICATE MAY BE ISSUED OR MAY PERTAIN, THE INSURANCE AFFORDED BY THE POLICIES DESCRIBED HEREIN IS SUBJECT TO ALL THE TERMS, EXCLUSIONS AND CONDITIONS OF SUCH POLICIES. LIMITS SHOWN MAY HAVE BEEN REDUCED BY PAID CLAIMS.

INSR LTR	TYPE OF INSURANCE	ADDL INSR	SUBR WVD	POLICY NUMBER	POLICY EFF (MM/DD/YYYY)	POLICY EXP (MM/DD/YYYY)	LIMITS	
A	<input checked="" type="checkbox"/> GENERAL LIABILITY	X		Q61-0320184	09/16/2023	09/16/2024	EACH OCCURRENCE	\$ 1,000,000
	<input checked="" type="checkbox"/> COMMERCIAL GENERAL LIABILITY						DAMAGE TO RENTED PREMISES (Ea occurrence)	\$ 1,000,000
	<input type="checkbox"/> CLAIMS-MADE <input checked="" type="checkbox"/> OCCUR						MED EXP (Any one person)	\$ 5,000
	GEN'L AGGREGATE LIMIT APPLIES PER:						PERSONAL & ADV INJURY	\$ 1,000,000
	<input type="checkbox"/> POLICY <input type="checkbox"/> PRO-JECT <input type="checkbox"/> LOC						GENERAL AGGREGATE	\$ 2,000,000
	AUTOMOBILE LIABILITY						PRODUCTS - COMP/OP AGG	\$ 2,000,000
	<input type="checkbox"/> ANY AUTO						COMBINED SINGLE LIMIT (Ea accident)	\$
	<input type="checkbox"/> ALL OWNED AUTOS						BODILY INJURY (Per person)	\$
	<input type="checkbox"/> SCHEDULED AUTOS						BODILY INJURY (Per accident)	\$
	<input type="checkbox"/> HIRED AUTOS						PROPERTY DAMAGE (PER ACCIDENT)	\$
	<input type="checkbox"/> NON-OWNED AUTOS							\$
	<input type="checkbox"/> UMBRELLA LIAB <input type="checkbox"/> EXCESS LIAB						EACH OCCURRENCE	\$
	<input type="checkbox"/> OCCUR <input type="checkbox"/> CLAIMS-MADE						AGGREGATE	\$
	<input type="checkbox"/> DEDUCTIBLE							\$
	<input type="checkbox"/> RETENTION \$							\$
	WORKERS COMPENSATION AND EMPLOYERS' LIABILITY						<input type="checkbox"/> WC STATUTORY LIMITS <input type="checkbox"/> OTHER	
	ANY PROPRIETOR/PARTNER/EXECUTIVE OFFICER/MEMBER EXCLUDED? (Mandatory in NH)		Y / N				E.L. EACH ACCIDENT	\$
	If yes, describe under DESCRIPTION OF OPERATIONS below		<input type="checkbox"/> N / A				E.L. DISEASE - EA EMPLOYEE	\$
							E.L. DISEASE - POLICY LIMIT	\$

DESCRIPTION OF OPERATIONS / LOCATIONS / VEHICLES (Attach ACORD 101, Additional Remarks Schedule, if more space is required)

Illinois Department of Transportation is added as an Additional Insured with respect to the Highland Jaycees road closure of IL. State Route 160 from Spindler Park Lane to Cypress St on Saturday, June 8, 2024 from 4:45pm until 6:30pm for the purpose of conducting the annual Schweizerfest Parade

CERTIFICATE HOLDER**CANCELLATION**

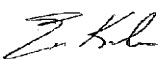
ILLINOI Illinois Department of Transportation Division of Highways District8 1102 Eastport Plaza Dr Collinsville, IL 62234	SHOULD ANY OF THE ABOVE DESCRIBED POLICIES BE CANCELLED BEFORE THE EXPIRATION DATE THEREOF, NOTICE WILL BE DELIVERED IN ACCORDANCE WITH THE POLICY PROVISIONS. AUTHORIZED REPRESENTATIVE 
--	---

© 1988-2009 ACORD CORPORATION. All rights reserved.



CERTIFICATE OF LIABILITY INSURANCE

OP ID: EK

DATE (MM/DD/YYYY)

01/30/2024

THIS CERTIFICATE IS ISSUED AS A MATTER OF INFORMATION ONLY AND CONFERS NO RIGHTS UPON THE CERTIFICATE HOLDER. THIS CERTIFICATE DOES NOT AFFIRMATIVELY OR NEGATIVELY AMEND, EXTEND OR ALTER THE COVERAGE AFFORDED BY THE POLICIES BELOW. THIS CERTIFICATE OF INSURANCE DOES NOT CONSTITUTE A CONTRACT BETWEEN THE ISSUING INSURER(S), AUTHORIZED REPRESENTATIVE OR PRODUCER, AND THE CERTIFICATE HOLDER.

IMPORTANT: If the certificate holder is an ADDITIONAL INSURED, the policy(ies) must be endorsed. If SUBROGATION IS WAIVED, subject to the terms and conditions of the policy, certain policies may require an endorsement. A statement on this certificate does not confer rights to the certificate holder in lieu of such endorsement(s).

PRODUCER Zimmerman Insurance Agency 1719 Troy Road, PO Box 508 Edwardsville, IL 62025 Eric Kolesa		CONTACT NAME: PHONE (A/C, No, Ext): _____ FAX (A/C, No): _____ E-MAIL ADDRESS: _____ PRODUCER CUSTOMER ID #: HIGHL-1	
INSURED Highland Jaycees P O Box 521 Highland, IL 62249		INSURER(S) AFFORDING COVERAGE INSURER A : Erie Insurance Group NAIC # 26271 INSURER B : _____ INSURER C : _____ INSURER D : _____ INSURER E : _____ INSURER F : _____	

COVERAGES**CERTIFICATE NUMBER:****REVISION NUMBER:**

THIS IS TO CERTIFY THAT THE POLICIES OF INSURANCE LISTED BELOW HAVE BEEN ISSUED TO THE INSURED NAMED ABOVE FOR THE POLICY PERIOD INDICATED. NOTWITHSTANDING ANY REQUIREMENT, TERM OR CONDITION OF ANY CONTRACT OR OTHER DOCUMENT WITH RESPECT TO WHICH THIS CERTIFICATE MAY BE ISSUED OR MAY PERTAIN, THE INSURANCE AFFORDED BY THE POLICIES DESCRIBED HEREIN IS SUBJECT TO ALL THE TERMS, EXCLUSIONS AND CONDITIONS OF SUCH POLICIES. LIMITS SHOWN MAY HAVE BEEN REDUCED BY PAID CLAIMS.

INSR LTR	TYPE OF INSURANCE	ADDL INSR	SUBR WVD	POLICY NUMBER	POLICY EFF (MM/DD/YYYY)	POLICY EXP (MM/DD/YYYY)	LIMITS	
A	GENERAL LIABILITY	X		Q61-0320184	09/16/2023	09/16/2024	EACH OCCURRENCE	\$ 1,000,000
	<input checked="" type="checkbox"/> COMMERCIAL GENERAL LIABILITY							
	<input type="checkbox"/> CLAIMS-MADE <input checked="" type="checkbox"/> OCCUR						DAMAGE TO RENTED PREMISES (Ea occurrence)	\$ 1,000,000
							MED EXP (Any one person)	\$ 5,000
							PERSONAL & ADV INJURY	\$ 1,000,000
							GENERAL AGGREGATE	\$ 2,000,000
	GEN'L AGGREGATE LIMIT APPLIES PER:						PRODUCTS - COMP/OP AGG	\$ 2,000,000
	<input type="checkbox"/> POLICY <input type="checkbox"/> PRO-JECT <input type="checkbox"/> LOC							\$
	AUTOMOBILE LIABILITY						COMBINED SINGLE LIMIT (Ea accident)	\$
	<input type="checkbox"/> ANY AUTO						BODILY INJURY (Per person)	\$
	<input type="checkbox"/> ALL OWNED AUTOS						BODILY INJURY (Per accident)	\$
	<input type="checkbox"/> SCHEDULED AUTOS						PROPERTY DAMAGE (PER ACCIDENT)	\$
	<input type="checkbox"/> HIRED AUTOS							\$
	<input type="checkbox"/> NON-OWNED AUTOS							\$
	UMBRELLA LIAB						EACH OCCURRENCE	\$
	<input type="checkbox"/> EXCESS LIAB						AGGREGATE	\$
	<input type="checkbox"/> DEDUCTIBLE							\$
	<input type="checkbox"/> RETENTION \$							\$
	WORKERS COMPENSATION AND EMPLOYERS' LIABILITY						WC STATUTORY LIMITS	OTHER
	ANY PROPRIETOR/PARTNER/EXECUTIVE OFFICER/MEMBER EXCLUDED? (Mandatory in NH)						E.L. EACH ACCIDENT	\$
	If yes, describe under DESCRIPTION OF OPERATIONS below						E.L. DISEASE - EA EMPLOYEE	\$
							E.L. DISEASE - POLICY LIMIT	\$

DESCRIPTION OF OPERATIONS / LOCATIONS / VEHICLES (Attach ACORD 101, Additional Remarks Schedule, if more space is required)

The City of Highland, Illinois is added as additional insured with respect to the Highland Jaycees Schweizerfest Parade Route Saturday, June 8, 2024 covering Broadway from Spindler Park Lane to Walnut, Walnut from Broadway to 9th St, 9th St from Walnut to Cypress, Cypress from 9th St to 12th St, 12th St from Cypress to Spindler Park Lane

CERTIFICATE HOLDER**CANCELLATION**

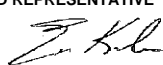
CITY OF HIGHLAND City of Highland 1115 Broadway P O Box 218 Highland, IL 62249	SHOULD ANY OF THE ABOVE DESCRIBED POLICIES BE CANCELLED BEFORE THE EXPIRATION DATE THEREOF, NOTICE WILL BE DELIVERED IN ACCORDANCE WITH THE POLICY PROVISIONS. AUTHORIZED REPRESENTATIVE 
---	---

© 1988-2009 ACORD CORPORATION. All rights reserved.



CERTIFICATE OF LIABILITY INSURANCE

OP ID: EK

DATE (MM/DD/YYYY)
01/30/2024

THIS CERTIFICATE IS ISSUED AS A MATTER OF INFORMATION ONLY AND CONFERS NO RIGHTS UPON THE CERTIFICATE HOLDER. THIS CERTIFICATE DOES NOT AFFIRMATIVELY OR NEGATIVELY AMEND, EXTEND OR ALTER THE COVERAGE AFFORDED BY THE POLICIES BELOW. THIS CERTIFICATE OF INSURANCE DOES NOT CONSTITUTE A CONTRACT BETWEEN THE ISSUING INSURER(S), AUTHORIZED REPRESENTATIVE OR PRODUCER, AND THE CERTIFICATE HOLDER.

IMPORTANT: If the certificate holder is an ADDITIONAL INSURED, the policy(ies) must be endorsed. If SUBROGATION IS WAIVED, subject to the terms and conditions of the policy, certain policies may require an endorsement. A statement on this certificate does not confer rights to the certificate holder in lieu of such endorsement(s).

PRODUCER Zimmerman Insurance Agency 1719 Troy Road, PO Box 508 Edwardsville, IL 62025 Eric Kolesa		CONTACT NAME: PHONE (A/C, No, Ext): _____ FAX (A/C, No): _____ E-MAIL ADDRESS: _____ PRODUCER CUSTOMER ID #: HIGHL-1	
INSURED Highland Jaycees P O Box 521 Highland, IL 62249		INSURER(S) AFFORDING COVERAGE INSURER A: Erie Insurance Group NAIC # 26271 INSURER B: _____ INSURER C: _____ INSURER D: _____ INSURER E: _____ INSURER F: _____	

COVERAGES**CERTIFICATE NUMBER:****REVISION NUMBER:**

THIS IS TO CERTIFY THAT THE POLICIES OF INSURANCE LISTED BELOW HAVE BEEN ISSUED TO THE INSURED NAMED ABOVE FOR THE POLICY PERIOD INDICATED. NOTWITHSTANDING ANY REQUIREMENT, TERM OR CONDITION OF ANY CONTRACT OR OTHER DOCUMENT WITH RESPECT TO WHICH THIS CERTIFICATE MAY BE ISSUED OR MAY PERTAIN, THE INSURANCE AFFORDED BY THE POLICIES DESCRIBED HEREIN IS SUBJECT TO ALL THE TERMS, EXCLUSIONS AND CONDITIONS OF SUCH POLICIES. LIMITS SHOWN MAY HAVE BEEN REDUCED BY PAID CLAIMS.

INSR LTR	TYPE OF INSURANCE	ADDL INSR	SUBR WVD	POLICY NUMBER	POLICY EFF (MM/DD/YYYY)	POLICY EXP (MM/DD/YYYY)	LIMITS	
A	<input checked="" type="checkbox"/> GENERAL LIABILITY <input checked="" type="checkbox"/> COMMERCIAL GENERAL LIABILITY <input type="checkbox"/> CLAIMS-MADE <input checked="" type="checkbox"/> OCCUR GEN'L AGGREGATE LIMIT APPLIES PER: <input type="checkbox"/> POLICY <input type="checkbox"/> PRO-JECT <input type="checkbox"/> LOC	X		Q61-0320184	09/16/2023	09/16/2024	EACH OCCURRENCE	\$ 1,000,000
	DAMAGE TO RENTED PREMISES (Ea occurrence)						\$ 1,000,000	
							MED EXP (Any one person)	\$ 5,000
							PERSONAL & ADV INJURY	\$ 1,000,000
							GENERAL AGGREGATE	\$ 2,000,000
							PRODUCTS - COMP/OP AGG	\$ 2,000,000
								\$
	AUTOMOBILE LIABILITY <input type="checkbox"/> ANY AUTO <input type="checkbox"/> ALL OWNED AUTOS <input type="checkbox"/> SCHEDULED AUTOS <input type="checkbox"/> HIRED AUTOS <input type="checkbox"/> NON-OWNED AUTOS						COMBINED SINGLE LIMIT (Ea accident)	\$
							BODILY INJURY (Per person)	\$
							BODILY INJURY (Per accident)	\$
							PROPERTY DAMAGE (PER ACCIDENT)	\$
								\$
								\$
	UMBRELLA LIAB <input type="checkbox"/> OCCUR EXCESS LIAB <input type="checkbox"/> CLAIMS-MADE DEDUCTIBLE _____ RETENTION \$ _____						EACH OCCURRENCE	\$
							AGGREGATE	\$
								\$
								\$
	WORKERS COMPENSATION AND EMPLOYERS' LIABILITY ANY PROPRIETOR/PARTNER/EXECUTIVE OFFICER/MEMBER EXCLUDED? (Mandatory in NH) <input type="checkbox"/> Y/N <input checked="" type="checkbox"/> N/A If yes, describe under DESCRIPTION OF OPERATIONS below						WC STATUTORY LIMITS	OTHER
							E.L. EACH ACCIDENT	\$
							E.L. DISEASE - EA EMPLOYEE	\$
							E.L. DISEASE - POLICY LIMIT	\$

DESCRIPTION OF OPERATIONS / LOCATIONS / VEHICLES (Attach ACORD 101, Additional Remarks Schedule, if more space is required)

The City of Highland is added as additional insured is added as additional insured with respect to the Highland Jaycees' Schweizerfest Event to be held from Thursday June 6, 2024 through Monday, June 10, 2024.

CERTIFICATE HOLDER**CANCELLATION**

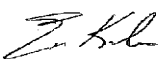
HIGHLAN City of Highland 1115 Broadway Highland, IL 62249	SHOULD ANY OF THE ABOVE DESCRIBED POLICIES BE CANCELLED BEFORE THE EXPIRATION DATE THEREOF, NOTICE WILL BE DELIVERED IN ACCORDANCE WITH THE POLICY PROVISIONS. AUTHORIZED REPRESENTATIVE 
---	---

© 1988-2009 ACORD CORPORATION. All rights reserved.



CERTIFICATE OF LIABILITY INSURANCE

OP ID: EK

DATE (MM/DD/YYYY)

01/30/2024

THIS CERTIFICATE IS ISSUED AS A MATTER OF INFORMATION ONLY AND CONFERS NO RIGHTS UPON THE CERTIFICATE HOLDER. THIS CERTIFICATE DOES NOT AFFIRMATIVELY OR NEGATIVELY AMEND, EXTEND OR ALTER THE COVERAGE AFFORDED BY THE POLICIES BELOW. THIS CERTIFICATE OF INSURANCE DOES NOT CONSTITUTE A CONTRACT BETWEEN THE ISSUING INSURER(S), AUTHORIZED REPRESENTATIVE OR PRODUCER, AND THE CERTIFICATE HOLDER.

IMPORTANT: If the certificate holder is an ADDITIONAL INSURED, the policy(ies) must be endorsed. If SUBROGATION IS WAIVED, subject to the terms and conditions of the policy, certain policies may require an endorsement. A statement on this certificate does not confer rights to the certificate holder in lieu of such endorsement(s).

PRODUCER Zimmerman Insurance Agency 1719 Troy Road, PO Box 508 Edwardsville, IL 62025 Eric Kolesa		CONTACT NAME: PHONE (A/C, No, Ext): _____ FAX (A/C, No): _____ E-MAIL ADDRESS: _____ PRODUCER CUSTOMER ID #: HIGHL-1	
INSURED Highland Jaycees P O Box 521 Highland, IL 62249		INSURER(S) AFFORDING COVERAGE INSURER A : Erie Insurance Group NAIC # 26271 INSURER B : _____ INSURER C : _____ INSURER D : _____ INSURER E : _____ INSURER F : _____	

COVERAGES**CERTIFICATE NUMBER:****REVISION NUMBER:**

THIS IS TO CERTIFY THAT THE POLICIES OF INSURANCE LISTED BELOW HAVE BEEN ISSUED TO THE INSURED NAMED ABOVE FOR THE POLICY PERIOD INDICATED. NOTWITHSTANDING ANY REQUIREMENT, TERM OR CONDITION OF ANY CONTRACT OR OTHER DOCUMENT WITH RESPECT TO WHICH THIS CERTIFICATE MAY BE ISSUED OR MAY PERTAIN, THE INSURANCE AFFORDED BY THE POLICIES DESCRIBED HEREIN IS SUBJECT TO ALL THE TERMS, EXCLUSIONS AND CONDITIONS OF SUCH POLICIES. LIMITS SHOWN MAY HAVE BEEN REDUCED BY PAID CLAIMS.

INSR LTR	TYPE OF INSURANCE	ADDL INSR	SUBR WVD	POLICY NUMBER	POLICY EFF (MM/DD/YYYY)	POLICY EXP (MM/DD/YYYY)	LIMITS	
A	GENERAL LIABILITY <input checked="" type="checkbox"/> COMMERCIAL GENERAL LIABILITY <input type="checkbox"/> CLAIMS-MADE <input checked="" type="checkbox"/> OCCUR GEN'L AGGREGATE LIMIT APPLIES PER: <input type="checkbox"/> POLICY <input type="checkbox"/> PRO-JECT <input type="checkbox"/> LOC	X		Q61-0320184	09/16/2023	09/16/2024	EACH OCCURRENCE	\$ 1,000,000
	DAMAGE TO RENTED PREMISES (Ea occurrence)						\$ 1,000,000	
							MED EXP (Any one person)	\$ 5,000
							PERSONAL & ADV INJURY	\$ 1,000,000
							GENERAL AGGREGATE	\$ 2,000,000
							PRODUCTS - COMP/OP AGG	\$ 2,000,000
								\$
	AUTOMOBILE LIABILITY <input type="checkbox"/> ANY AUTO <input type="checkbox"/> ALL OWNED AUTOS <input type="checkbox"/> SCHEDULED AUTOS <input type="checkbox"/> HIRED AUTOS <input type="checkbox"/> NON-OWNED AUTOS						COMBINED SINGLE LIMIT (Ea accident)	\$
							BODILY INJURY (Per person)	\$
							BODILY INJURY (Per accident)	\$
							PROPERTY DAMAGE (PER ACCIDENT)	\$
								\$
								\$
	UMBRELLA LIAB <input type="checkbox"/> OCCUR EXCESS LIAB <input type="checkbox"/> CLAIMS-MADE DEDUCTIBLE RETENTION \$						EACH OCCURRENCE	\$
							AGGREGATE	\$
								\$
								\$
	WORKERS COMPENSATION AND EMPLOYERS' LIABILITY Y/N ANY PROPRIETOR/PARTNER/EXECUTIVE OFFICER/MEMBER EXCLUDED? (Mandatory in NH) <input type="checkbox"/> N/A If yes, describe under DESCRIPTION OF OPERATIONS below						WC STATUTORY LIMITS	OTHER
							E.L. EACH ACCIDENT	\$
							E.L. DISEASE - EA EMPLOYEE	\$
							E.L. DISEASE - POLICY LIMIT	\$

DESCRIPTION OF OPERATIONS / LOCATIONS / VEHICLES (Attach ACORD 101, Additional Remarks Schedule, if more space is required)

Illinois Department of Transportation is added as additional insured with respect to the Highland Jaycees' Schweizerfest Event to be held from Thursday June 6, 2024 through Monday, June 10, 2024

CERTIFICATE HOLDER**CANCELLATION**

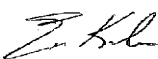
ILLINTR Illinois Department of Transportation Division of Highways Dist. 8 1102 Eastport Plaza Dr. Collinsville, IL 62234	SHOULD ANY OF THE ABOVE DESCRIBED POLICIES BE CANCELLED BEFORE THE EXPIRATION DATE THEREOF, NOTICE WILL BE DELIVERED IN ACCORDANCE WITH THE POLICY PROVISIONS. AUTHORIZED REPRESENTATIVE 
---	---

© 1988-2009 ACORD CORPORATION. All rights reserved.

CITY OF HIGHLAND



SPECIAL EVENT APPLICATION

Authorized under City Ordinance Sec. 64-3-1

PURPOSE: The City of Highland supports various community activities and festivals throughout the year. Establishing public safety and coordinating needs between the events and the city are the overall goals of this process. It is the responsibility of the specific event Sponsors to obtain, complete, and follow through the application process for city approval.

DEFINITIONS and FEES:

Special event: A "Special Event" is defined as: (1) any event, race, gathering, demonstration, or service; (2) that occurs partially or completely within the jurisdiction of the City of Highland; (3) is expected to draw crowds in excess of one hundred fifty (150) attendees; and (4) is expected to or could disrupt normal daily functions within the City of Highland including but not limited to traffic congestion and excess noise; or could create a public health/safety concern without proper precautions or prior planning. Specific examples would include (but are not limited to): The Kirchenfest, Schweizerfest, 5K runs, parades, Art in the Park, Fourth of July Festivities, Madison County Fair, etc. The City Manager will make the final determination as to whether an event qualifies. This will be based upon the totality of the circumstances presented.

Ongoing Event: An "Ongoing Event" is defined as any event that occurs partially or completely within the jurisdiction of the City of Highland consecutively for a period of time that exceeds more than two times monthly. Specific examples would include (but are not limited to): automobile races, re-occurring sporting events not affiliated with HUSD5, weekly music festivals, and other weekly reoccurring events). The City Manager will make the final determination as to whether an event qualifies. This will be based on the totality of the circumstances presented and will require approval depending on requests of individual departments by their Directors.

Highland Public Safety Fees for Special Events:

Police Department: The Highland Police Department will be paid at a rate of \$50.00 per officer per race event (runs or bicycle) when required for traffic control. The Highland Police Department will be paid at a rate of \$100.00 per officer per day, per event when officers are requested outside of the normal day-to-day operation.

Emergency Medical Services Department: No additional fees for Special Events unless organizers require service outside of the normal day-to-day operation.

Fire Department:

No additional fees for Special Events unless organizers require service outside of the normal day-to-day operation.

Highland Public Safety Fees for On-Going Events:

Police Department: The Highland Police Department will be reimbursed at a rate of 1 ½ times the rate of the officer working the ongoing event. Scheduling will be arranged and agreed upon by the organizer, the Chief of Police or his/her designee.

Emergency Medical Services Department:

The Highland Emergency Medical Services Department will be paid at a rate of \$75.00 per half hour when requested for an ongoing event. Scheduling will be arranged and agreed upon by the organizer and the EMS Chief or his/her designee. The following are details of provided additional service:

- Two crew members to provide medical services throughout the event.
- Fuel charges consistent with leaded mile rate.
- Medical supplies used during the event
- Wear and tear on the truck for idle state

Trucks must remain in an idle state throughout the course of the event for patient comfort and to maintain moderate temperatures for medications and I.V. fluids. Scheduling will be arranged and agreed upon by the organizer and the Emergency Services Chief or his/her designee.

Fire Department:

The Highland Fire Department will be reimbursed at a rate of \$21.00 per firefighter per hour working the ongoing event. Scheduling will be arranged and agreed upon by the organizer and the Fire Chief or his/her designee.

PROCEDURE:

1. All Requests will be directed to Highland City Hall, to the attention of the Director of Support Services.
2. Applications will be available at Highland City Hall, Monday-Friday, 8:00 am to 5:00 pm or online through the City's web site.
3. Applications will be completed by the Event Sponsor and submitted at least 60 days prior to the event. The application must be signed by the Event Sponsor Responsible Party. Incomplete applications will not be accepted. If an application is accepted and later determined to be incomplete, the applicant will be notified by the Director of Support Services. Failure to provide information will result in denial of application.
4. The Director of Support Services will forward the application to all city departments that have responsibilities relating to the event. If necessary, a committee meeting involving the event Sponsor and city stakeholders may take place to clarify questions, determine specific needs, and address concerns.
5. The event Sponsor is required to obtain final approval for the special event from the City Manager. The City Council may announce the special event to the public at a scheduled Council meeting.

CITY OF HIGHLAND-SPECIAL EVENT APPLICATION

Name of Event: Highland Chamber of Commerce Business After Hours

Type of Event: Festival Race Other Fundraiser Service Parade
 Other (please specify): Business After Hours

Description of Event: Business After Hours Event
Digital Artz: Clarity Hosting. Want to make sure
Guests can cross the street w/o danger

Location of Event: 305 Forest Dr. / 188 Woodcrest Dr.

Sponsoring Organization/Individual: CHRIS EBL / JOSH HETLEY

Event Responsible Party: CHRIS EBL
Address: 305 FOREST DR
Phone(s): 618-651-1500
Email: chris@digitalartz.us

Date(s) of Set-up: March 21st, 2024

Event Date(s) / Times: Event 5-7 pm / Street Closure 4:00-8pm

Date(s) of Tear-down: March 21st 2024

Expected Attendance: 60-80 people

Alcohol License Required: Yes No
If yes, application submitted: Yes No

Sound Amplification System utilized: Yes No (Only available for the Square)
If yes, hours of operation: _____

Funding request of the Council: Yes No
Amount requested: \$ _____
Purpose for Funding: _____

Street Dept: Signage, Barricades, Street Closures (Specify): Barricades and
Notifications prior @ Woodcrest and Poplar
AND WOODCREST & FOREST DR

Electric Dept: Electrical Service, Lighting (Specify): NONE

Public Safety: If anything needed in addition to below (Specify):

HCS Services: Wi-Fi or other technological needs (Specify):

Other City Services: Restrooms, City Officials, Refuse Dumpsters-Charges Apply (Specify):

Signs: Per the City of Highland's Municipal Code, signs are disallowed on public right-of-way. If you wish to display signs on right-of-way, please indicate the requested location of signs: FOREST & WOODCREST

WOODCREST & POPLAR

If approval is granted, signs must not be displayed within roundabouts or within any area that is difficult for vehicles to see around and creates a traffic safety issue. All signs within right-of-way must be displayed no more than two weeks prior to the event unless specifically requested and removed within two days after the event.

Specify Special Event or Ongoing Event (as defined above) _____

Specify Route Option # _____ (listed on attached Maps)

Route must be approved by Public Safety director before application can be brought to council for approval.

Check the boxes below for what Services apply and number of each service needed
(See Page 1&2 and Race Option/Maps provided for more information)

- Police** – Number of officers needed for Event _____
- EMS** – Number of Emergency Medics needed for Event _____
- Fire** – Number of Firefighters needed for Event _____

Application Checklist (Attachments):

- Council Meeting Scheduled for approval
- Certificate of Insurance: (Must attached for approval)
 - o Must be General liability
 - o \$1 Million per occurrence/\$2 million aggregate
 - o City named as "additional insured" If Event is on city property.
- Site Plan Rendering
- Evacuation Plan
- Fire Plan
- Parking Plan

City Services Requested: – Please attach additional documents such as maps, flyers or any other detailed information.

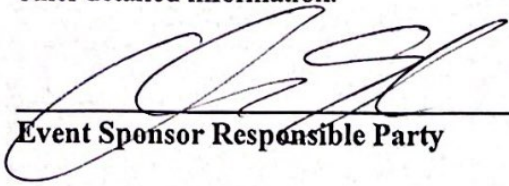

Event Sponsor Responsible Party

1-22-2024
Date

City Manager

Date

CITY OF HIGHLAND



SPECIAL EVENT APPLICATION

Authorized under City Ordinance Sec. 64-3-1

PURPOSE: The City of Highland supports various community activities and festivals throughout the year. Establishing public safety and coordinating needs between the events and the city are the overall goals of this process. It is the responsibility of the specific event Sponsors to obtain, complete, and follow through the application process for city approval.

DEFINITIONS and FEES:

Special event: A "Special Event" is defined as: (1) any event, race, gathering, demonstration, or service; (2) that occurs partially or completely within the jurisdiction of the City of Highland; (3) is expected to draw crowds in excess of one hundred fifty (150) attendees; and (4) is expected to or could disrupt normal daily functions within the City of Highland including but not limited to traffic congestion and excess noise; or could create a public health/safety concern without proper precautions or prior planning. Specific examples would include (but are not limited to): The Kirchenfest, Schweizerfest, 5K runs, parades, Art in the Park, Fourth of July Festivities, Madison County Fair, etc. The City Manager will make the final determination as to whether an event qualifies. This will be based upon the totality of the circumstances presented.

Ongoing Event: An "Ongoing Event" is defined as any event that occurs partially or completely within the jurisdiction of the City of Highland consecutively for a period of time that exceeds more than two times monthly. Specific examples would include (but are not limited to): automobile races, re-occurring sporting events not affiliated with HUSD5, weekly music festivals, and other weekly reoccurring events). The City Manager will make the final determination as to whether an event qualifies. This will be based on the totality of the circumstances presented and will require approval depending on requests of individual departments by their Directors.

Highland Public Safety Fees for Special Events:

Police Department: The Highland Police Department will be paid at a rate of \$50.00 per officer per race event (runs or bicycle) when required for traffic control. The Highland Police Department will be paid at a rate of \$100.00 per officer per day, per event when officers are requested outside of the normal day-to-day operation.

Emergency Medical Services Department: No additional fees for Special Events unless organizers require service outside of the normal day-to-day operation.

Fire Department:

No additional fees for Special Events unless organizers require service outside of the normal day-to-day operation.

Highland Public Safety Fees for On-Going Events:

Police Department: The Highland Police Department will be reimbursed at a rate of 1 ½ times the rate of the officer working the ongoing event. Scheduling will be arranged and agreed upon by the organizer, the Chief of Police or his/her designee.

Emergency Medical Services Department:

The Highland Emergency Medical Services Department will be paid at a rate of \$75.00 per half hour when requested for an ongoing event. Scheduling will be arranged and agreed upon by the organizer and the EMS Chief or his/her designee. The following are details of provided additional service:

- Two crew members to provide medical services throughout the event.
- Fuel charges consistent with leaded mile rate.
- Medical supplies used during the event
- Wear and tear on the truck for idle state

Trucks must remain in an idle state throughout the course of the event for patient comfort and to maintain moderate temperatures for medications and I.V. fluids. Scheduling will be arranged and agreed upon by the organizer and the Emergency Services Chief or his/her designee.

Fire Department:

The Highland Fire Department will be reimbursed at a rate of \$21.00 per firefighter per hour working the ongoing event. Scheduling will be arranged and agreed upon by the organizer and the Fire Chief or his/her designee.

PROCEDURE:

1. All Requests will be directed to Highland City Hall, to the attention of the Director of Support Services.
2. Applications will be available at Highland City Hall, Monday-Friday, 8:00 am to 5:00 pm or online through the City's web site.
3. Applications will be completed by the Event Sponsor and submitted at least 60 days prior to the event. The application must be signed by the Event Sponsor Responsible Party. Incomplete applications will not be accepted. If an application is accepted and later determined to be incomplete, the applicant will be notified by the Director of Support Services. Failure to provide information will result in denial of application.
4. The Director of Support Services will forward the application to all city departments that have responsibilities relating to the event. If necessary, a committee meeting involving the event Sponsor and city stakeholders may take place to clarify questions, determine specific needs, and address concerns.
5. The event Sponsor is required to obtain final approval for the special event from the City Manager. The City Council may announce the special event to the public at a scheduled Council meeting.

CITY OF HIGHLAND-SPECIAL EVENT APPLICATION

Name of Event: Speedway Races

Type of Event: Festival Race Other Fundraiser Service Parade
 Other (please specify): _____

Description of Event: weekly schedule of stock
car races

Location of Event: Madison County Fairgrounds

Sponsoring Organization/Individual: Madison County Fair Assn

Event Responsible Party: Shaun Horstmann

Address: _____

Phone(s): 618-792-8147

Email: Shaun.horstmann54@gmail.com

Date(s) of Set-up: n/a

Event Date(s) / Times: see attached schedule

Date(s) of Tear-down: n/a

Expected Attendance: _____

Alcohol License Required: Yes No

If yes, application submitted: Yes No

Sound Amplification System utilized: Yes No (Only available for the Square)

If yes, hours of operation: 6:00-11:00 pm

Funding request of the Council: Yes No

Amount requested: \$ _____

Purpose for Funding: _____

Street Dept: Signage, Barricades, Street Closures (Specify): _____

n/a

Electric Dept: Electrical Service, Lighting (Specify): _____

n/a

Public Safety: If anything needed in addition to below (Specify):

n/a

HCS Services: Wi-Fi or other technological needs (Specify):

already have cameras and wiFi and telephone

Other City Services: Restrooms, City Officials, Refuse Dumpsters-Charges Apply (Specify):

n/a

Signs: Per the City of Highland's Municipal Code, signs are disallowed on public right-of-way. If you wish to display signs on right-of-way, please indicate the requested location of signs:

other sheet turned in by Kurt Vonder Haar

If approval is granted, signs must not be displayed within roundabouts or within any area that is difficult for vehicles to see around and creates a traffic safety issue. All signs within right-of-way must be displayed no more than two weeks prior to the event unless specifically requested and removed within two days after the event.

Specify Special Event or Ongoing Event (as defined above) stock car races

Specify Route Option # n/a (listed on attached Maps)

Route must be approved by Public Safety director before application can be brought to council for approval.

Check the boxes below for what Services apply and number of each service needed

(See Page 1&2 and Race Option/Maps provided for more information)

- Police – Number of officers needed for Event 2 special events June 29 + Aug 14 and March 16
- EMS – Number of Emergency Medics needed for Event 2 April 20
- Fire – Number of Firefighters needed for Event 2 May 4
May 18

Application Checklist (Attachments):

- Council Meeting Scheduled for approval
- Certificate of Insurance: (Must attached for approval)
 - Must be General liability
 - \$1 Million per occurrence/\$2 million aggregate
 - City named as "additional insured" If Event is on city property.
- Site Plan Rendering
- Evacuation Plan
- Fire Plan
- Parking Plan

June 29
July 20
July 24
Aug 3
Aug 14
Sept 7
Sept 14

Highland Speedway Evacuation/Fire Plan

The Madison County Fairgrounds is an outside venue. The grandstand has exits on the top, the bottom, and each side. If weather is threatening, there is the basement under the grandstands. People may also evacuate to the Expo Building. They can go out up top by the ticket booth and walk down the ramp to the basement of the Expo Building. If needed, people can go up the stairs in the Expo building to the top level.

Highland Speedway Parking Plan

During the weekly races at the Highland Speedway, parking is located on the property of the Madison County Fairgrounds as well as the parking lots at the schools and the 4 diamonds, north of the Highland Elementary Schools.

Site Rendering

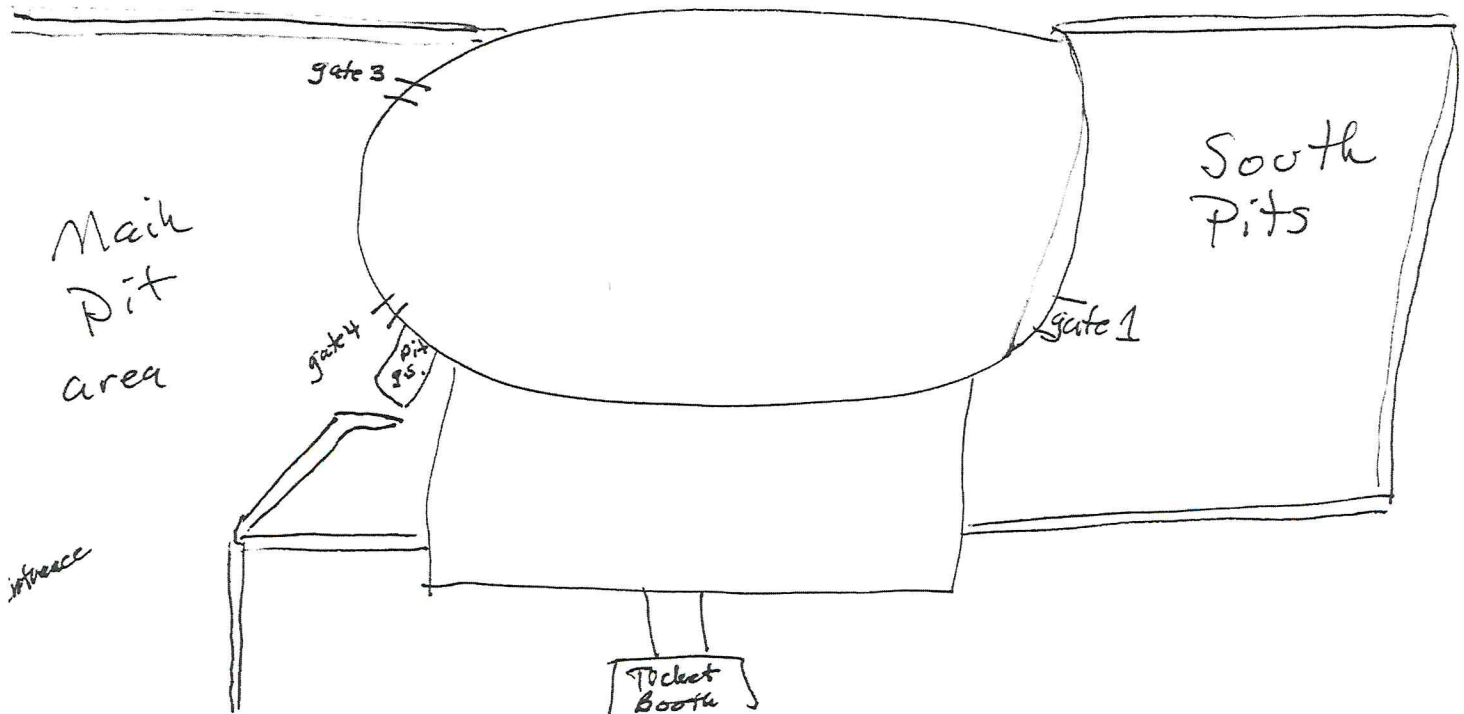

City Services Requested: – Please attach additional documents such as maps, flyers or any other detailed information.

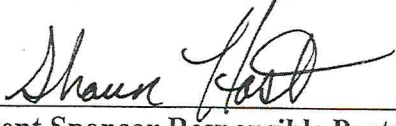

Event Sponsor Responsible Party

Jan 30, 2024
Date

City Manager

Date

JUN 1	SATURDAY, 01 JUNE 2024 Points Night DIRTcar UMP Modifieds, UMP ProModifieds, Street Stocks, Micros	DETAILS
JUN 4	TUESDAY, 04 JUNE 2024 Test n Tune DIRTcar Late Models, DIRTcar UMP Modifieds, UMP ProModifieds, Street Stocks, Micros, Warriors, Vintage Cars	DETAILS
JUN 8	SATURDAY, 08 JUNE 2024 Points Night DIRTcar Late Models, DIRTcar UMP Modifieds, UMP ProModifieds, Street Stocks	DETAILS
JUN 15	SATURDAY, 15 JUNE 2024 Points Night DIRTcar Late Models, DIRTcar UMP Modifieds, UMP ProModifieds, Street Stocks, Economy Sprints - Non Winged	DETAILS
JUN 22	SATURDAY, 22 JUNE 2024 Pit Stop	DETAILS
JUN 29	SATURDAY, 29 JUNE 2024 Summer Nationals DIRTcar Summer Nationals, DIRTcar UMP Modifieds	DETAILS
JUL 2	TUESDAY, 02 JULY 2024 Test n Tune DIRTcar Late Models, DIRTcar UMP Modifieds, UMP ProModifieds, Street Stocks, Micros, Warriors, Vintage Cars	DETAILS
JUL 6	SATURDAY, 06 JULY 2024 Points Night DIRTcar Late Models, DIRTcar UMP Modifieds, UMP ProModifieds, Street Stocks	DETAILS
JUL 13	SATURDAY, 13 JULY 2024 Points Night DIRTcar UMP Modifieds, UMP ProModifieds, Street Stocks, Micros, Warriors	DETAILS
JUL 20	SATURDAY, 20 JULY 2024 Josh Melton Memorial Race DIRTcar UMP Modifieds, UMP ProModifieds, Street Stocks, Warriors	DETAILS
JUL 24	WEDNESDAY, 24 JULY 2024 Challenge of Champions DIRTcar Late Models, DIRTcar UMP Modifieds, UMP ProModifieds	DETAILS
JUL 27	SATURDAY, 27 JULY 2024 Pit Stop - Madison County Fair	DETAILS
AUG 3	SATURDAY, 03 AUGUST 2024 Leaps of Love Race DIRTcar Late Models, DIRTcar UMP Modifieds, UMP ProModifieds, Street Stocks	DETAILS
AUG 6	TUESDAY, 06 AUGUST 2024 Test n Tune DIRTcar Late Models, DIRTcar UMP Modifieds, UMP ProModifieds, Street Stocks, Micros, Warriors, Vintage Cars	DETAILS
AUG 10	SATURDAY, 10 AUGUST 2024 Points Night DIRTcar UMP Modifieds, UMP ProModifieds, Street Stocks, Micros, Warriors	DETAILS
AUG 14	WEDNESDAY, 14 AUGUST 2024 World of Outlaws Race DIRTcar UMP Modifieds	DETAILS
AUG 17	SATURDAY, 17 AUGUST 2024 Points Night DIRTcar UMP Modifieds, UMP ProModifieds, Street Stocks, Micros, Warriors	DETAILS



HIGHLAND SPEEDWAY

HIGHLAND, IL

Schedule & Results

2024 EVENTS

2024 ▾

MAR 10	SUNDAY, 10 MARCH 2024 Play Day DIRTcar Late Models, DIRTcar UMP Modifieds, UMP ProModifieds, Street Stocks, Micros, Warriors, Vintage Cars	DETAILS
MAR 16	SATURDAY, 16 MARCH 2024 Opening Night DIRTcar Late Models, DIRTcar UMP Modifieds, UMP ProModifieds, Street Stocks	DETAILS
MAR 23	SATURDAY, 23 MARCH 2024 Points Night DIRTcar UMP Modifieds, UMP ProModifieds, Street Stocks, Micros, Warriors	DETAILS
MAR 30	SATURDAY, 30 MARCH 2024 Points Night DIRTcar Late Models, DIRTcar UMP Modifieds, UMP ProModifieds, Street Stocks	DETAILS
APR 2	TUESDAY, 02 APRIL 2024 Test n Tune DIRTcar Late Models, DIRTcar UMP Modifieds, UMP ProModifieds, Street Stocks, Micros, Warriors, Vintage Cars	DETAILS
APR 6	SATURDAY, 06 APRIL 2024 Points Night DIRTcar UMP Modifieds, UMP ProModifieds, Street Stocks, Throwback Sprints	DETAILS
APR 13	SATURDAY, 13 APRIL 2024 Points Night DIRTcar Late Models, DIRTcar UMP Modifieds, UMP ProModifieds, Street Stocks, Warriors	DETAILS
APR 20	SATURDAY, 20 APRIL 2024 MARS Racing Nght MARS - Midwest Auto Racing Series, DIRTcar UMP Modifieds, UMP ProModifieds, Street Stocks, Micros	DETAILS
APR 27	SATURDAY, 27 APRIL 2024 Points Night DIRTcar Late Models, DIRTcar UMP Modifieds, UMP ProModifieds, Street Stocks	DETAILS
MAY 4	SATURDAY, 04 MAY 2024 MOWA Sprints Night DIRTcar UMP Modifieds, UMP ProModifieds, Street Stocks, Micros, Warriors	DETAILS
MAY 7	TUESDAY, 07 MAY 2024 Test n Tune DIRTcar Late Models, DIRTcar UMP Modifieds, UMP ProModifieds, Street Stocks, Micros, Warriors, Vintage Cars	DETAILS
MAY 11	SATURDAY, 11 MAY 2024 Pit Stop	DETAILS
MAY 18	SATURDAY, 18 MAY 2024 Points Night MARS - Midwest Auto Racing Series, DIRTcar UMP Modifieds, UMP ProModifieds, Street Stocks, Micros	DETAILS
MAY 25	SATURDAY, 25 MAY 2024 Points Night DIRTcar Late Models, DIRTcar UMP Modifieds, UMP ProModifieds, Street Stocks, Warriors	DETAILS

AUG
24

SATURDAY, 24 AUGUST 2024

Points Night

DIRTcar Late Models, DIRTcar UMP Modifieds, UMP ProModifieds, Street Stocks

[DETAILS](#)

AUG
31

SATURDAY, 31 AUGUST 2024

Pit Stop

[DETAILS](#)

SEP
3

TUESDAY, 03 SEPTEMBER 2024

Test n Tune

DIRTcar Late Models, DIRTcar UMP Modifieds, UMP ProModifieds, Street Stocks, Micros, Warriors, Vintage Cars

[DETAILS](#)

SEP
7

SATURDAY, 07 SEPTEMBER 2024

Championship Night

DIRTcar Late Models, DIRTcar UMP Modifieds, UMP ProModifieds, Street Stocks

[DETAILS](#)

SEP
14

SATURDAY, 14 SEPTEMBER 2024

The Great Wide Open Night

WFO Winged Outlaw Micro Series

[DETAILS](#)

Providing motorsports marketing tools for drivers, teams, and promoters.

©2024 MyRacePass All rights reserved.

ACORD™

CERTIFICATE OF LIABILITY INSURANCE

USINGH1

DATE (MM/DD/YYYY) 3/24/23

THIS CERTIFICATE IS ISSUED AS A MATTER OF INFORMATION ONLY AND CONFERS NO RIGHTS UPON THE CERTIFICATE HOLDER. THIS CERTIFICATE DOES NOT AFFIRMATIVELY OR NEGATIVELY AMEND, EXTEND OR ALTER THE COVERAGE AFFORDED BY THE POLICIES BELOW. THIS CERTIFICATE OF INSURANCE DOES NOT CONSTITUTE A CONTRACT BETWEEN THE ISSUING INSURER(S), AUTHORIZED REPRESENTATIVE OR PRODUCER, AND THE CERTIFICATE HOLDER.

IMPORTANT: If the certificate holder is an ADDITIONAL INSURED, the policy(ies) must have ADDITIONAL INSURED provisions or be endorsed. If SUBROGATION IS WAIVED, subject to the terms and conditions of the policy, certain policies may require an endorsement. A statement on this certificate does not confer rights to the certificate holder in lieu of such endorsement(s).

PRODUCER: K & K Insurance Group, Inc. CONTACT NAME: MOTORSPORTS. INSURED: MADISON COUNTY FAIR ASSOCIATION. INSURER A: MARKEL INSURANCE COMPANY.

COVERAGES CERTIFICATE NUMBER: 2074284 REVISION NUMBER:

THIS IS TO CERTIFY THAT THE POLICIES OF INSURANCE LISTED BELOW HAVE BEEN ISSUED TO THE INSURED NAMED ABOVE FOR THE POLICY PERIOD INDICATED. NOTWITHSTANDING ANY REQUIREMENT, TERM OR CONDITION OF ANY CONTRACT OR OTHER DOCUMENT WITH RESPECT TO WHICH THIS CERTIFICATE MAY BE ISSUED OR MAY PERTAIN, THE INSURANCE AFFORDED BY THE POLICIES DESCRIBED HEREIN IS SUBJECT TO ALL THE TERMS, EXCLUSIONS AND CONDITIONS OF SUCH POLICIES. LIMITS SHOWN MAY HAVE BEEN REDUCED BY PAID CLAIMS.

Table with columns: INSR LTR, TYPE OF INSURANCE, ADDL INSD, SUBR WVD, POLICY NUMBER, POLICY EFF, POLICY EXP, LIMITS. Includes Commercial General Liability, Automobile Liability, Umbrella Liab, Workers Compensation, and Participant Accident.

DESCRIPTION OF OPERATIONS / LOCATIONS / VEHICLES (Attach ACORD 101, Additional Remarks Schedule, may be attached if more space is required) TYPE OF EVENT: PARKING FOR HIGHLAND SPEEDWAY

CERTIFICATE HOLDER: MADISON COUNTY FAIR ASSOCIATION. CANCELLATION: SHOULD ANY OF THE ABOVE DESCRIBED POLICIES BE CANCELLED BEFORE THE EXPIRATION DATE THEREOF, NOTICE WILL BE DELIVERED IN ACCORDANCE WITH THE POLICY PROVISIONS.

AGENCY CUSTOMER ID: _____

CERTIFICATE: 2074284 LOC # _____ DATE ISSUED: 3/24/23

ACORDTM

ADDITIONAL REMARKS SCHEDULE

Page 1 of 1

AGENCY K & K INSURANCE GROUP, INC.		NAMED INSURED MADISON COUNTY FAIR ASSOCIATION D/B/A HIGHLAND SPEEDWAY P.O. BOX 541 HIGHLAND, IL 62249	
POLICY NUMBER GL MKM0500339000 PA MKC0500339100			
CARRIER SEE ACORD 25	NAIC CODE	EFFECTIVE DATE: SEE ACORD 25	

ADDITIONAL REMARKS

THIS ADDITIONAL REMARKS FORM IS A SCHEDULE TO ACORD FORM,
FORM NUMBER: ACORD 25 FORM TITLE: CERTIFICATE OF LIABILITY INSURANCE

ADDITIONAL INSURED PER POLICY

- A. ANY PERSON OR ORGANIZATION ENGAGED IN OPERATING, MANAGING, SANCTIONING OR SPONSORING THE "COVERED PROGRAM," OR PROVIDING THE "PREMISES FOR A "COVERED PROGRAM," INCLUDING OFFICIALS OF THE "COVERED PROGRAM".
- B. ANY "PARTICIPANT" (EXCLUDING DRIVERS), "COMPETITION VEHICLE" OWNER AND "COMPETITION VEHICLE" SPONSOR.
- C. ANY "PARTICIPANT" DRIVER BUT ONLY WITH RESPECT TO "BODILY INJURY" OR "PROPERTY DAMAGE" TO PERSONS OTHER THAN OTHER DRIVER.

BUT ONLY AS RESPECTS TO THE OPERATIONS OF THE NAMED INSURED.

RESOLUTION NO. _____

WHEREAS, the Highland Jaycees is sponsoring their annual Schweizerfest in the City of Highland which event constitutes a public purpose;

WHEREAS, this event will require the temporary closure of IL Route 160, a State Highway in the City of Highland, IL from Walnut St. to Washington St.

WHEREAS, Section 4-408 of the Illinois Highway Code authorizes the Department of Transportation to issue permits to local authorities to temporarily close portions of State Highways for such public purposes.

NOW, THEREFORE, BE IT RESOLVED by the City Council of the City of Highland that permission to close off Illinois Route 160 from Walnut St. to Washington St. on (Thursday, June 6th, Friday, June 7th; Saturday, June 8th and Sunday, June 9th, 2024) as above designated, be requested of the Illinois Department of Transportation.

BE IT FURTHER RESOLVED, that this closure shall occur during the approximate time period between 6:00 PM on Thursday, June 6th, 2024, and 11:59 PM on Sunday, June 9th, 2024.

BE IT FURTHER RESOLVED, that this closure is for the public purpose of conducting the annual Schweizerfest event.

BE IT FURTHER RESOLVED, that traffic from that closed portion of highway shall be detoured over routes with an all-weather surface that can accept the anticipated traffic, which will be maintained to the satisfaction of the Department and which is conspicuously marked for the benefit of traffic diverted from the State highway. (The parking of vehicles shall be prohibited on the detour routes to allow an uninterrupted flow of two-way traffic, when appropriate.) The detour route shall be as follows: **Eastbound:** Detour west on Highland Rd. from IL Rte. 160 to Hemlock St., north on Hemlock to US Rte. 40, East on US Rte. 40 to IL Rte. 160. **Westbound:** Detour west on US Rte. 40 to Hemlock, south on Hemlock to Highland Rd., east on Highland Rd. to IL Rte. 160.

BE IT FURTHER RESOLVED, that the Highland Jaycees assumes full responsibility for the direction, protection and regulation of the traffic during the time the detour is in effect.

BE IT FURTHER RESOLVED, that police officers or authorized flaggers shall be positioned at each end of the closed section and at other points (such as intersections) as may be necessary to assist in directing traffic through the detour.

BE IT FURTHER RESOLVED, that police officers, flaggers and officials shall permit emergency vehicles in emergency situations to pass through the closed area as swiftly as is safe for all concerned.

BE IT FURTHER RESOLVED, that all debris shall be removed by the Highland Jaycees prior to reopening the State Highway.

BE IT FURTHER RESOLVED, that such signs, flags, barricades, etc., shall be used by the Highland Jaycees as may be approved by the Illinois Department of Transportation. These items shall be provided by the Highland Jaycees.

BE IT FURTHER RESOLVED, that the closure and detour shall be marked according to the Illinois Manual on Uniform Traffic Control Devices.

BE IT FURTHER RESOLVED, that an occasional break shall be made in the procession so that traffic may pass through. In any event, adequate provisions will be made for traffic on intersecting highways pursuant to conditions noted above. (Note: This paragraph is applicable when the Resolution pertains to a Parade or when no detour is required.)

BE IT FURTHER RESOLVED, that the Highland Jaycees hereby agrees to assume all liabilities and pay all claims for any damage which shall be occasioned by the closing described above.

BE IT FURTHER RESOLVED, that the Highland Jaycees shall provide a comprehensive general liability insurance policy or an additional insured endorsement in the amount of \$100,000 per person and \$500,000 aggregate which has the Illinois Department of Transportation and its officials, employees, and agents as additional insureds and which protects them from all claims arising from the requested road

closing.

BE IT FURTHER RESOLVED, that a copy of this Resolution be forwarded to the Illinois Department of Transportation to serve as a formal request for the permission sought in this resolution and to operate as part of the conditions of said permission.

ADOPTED by the City Council of the City of Highland on the ____ day of _____, 2024, and filed in the Office of the City Clerk this _____ day of _____, 2024.

AYES:

NOES:

ABSENT:

APPROVED:

Kevin B. Hemann
Mayor
City of Highland
Madison County, Illinois

ATTEST:

Barbara Bellm
City Clerk
City of Highland
Madison County, Illinois

RESOLUTION NO. _____

WHEREAS, the Highland Jaycees are sponsoring a parade in the City of Highland which event constitutes a public purpose;

WHEREAS, this parade will require the temporary closure of IL Route 160, a State Highway in the City of Highland, IL from Spindler Lane to Cypress Street.

WHEREAS, Section 4-408 of the Illinois Highway Code authorizes the Department of Transportation to issue permits to local authorities to temporarily close portions of State Highways for such public purposes.

NOW, THEREFORE, BE IT RESOLVED by the City Council of the City of Highland that permission to close off Illinois Route 160 from Spindler Lane to Cypress St. on Saturday, June 8th 2024, as above designated, be requested of the Illinois Department of Transportation.

BE IT FURTHER RESOLVED that this closure shall occur during the approximate time period between 4:45 PM and 6:30 PM on Saturday, June 8th, 2024.

BE IT FURTHER RESOLVED that this closure is for the public purpose of conducting a parade.

BE IT FURTHER RESOLVED, that traffic from that closed portion of highway shall be detoured over routes with an all-weather surface that can accept the anticipated traffic, which will be maintained to the satisfaction of the Department and which is conspicuously marked for the benefit of traffic diverted from the State highway. (The parking of vehicles shall be prohibited on the detour routes to allow an uninterrupted flow of two-way traffic, when appropriate.) The detour route shall be as follows: **Eastbound:** Detour west on Highland Rd. from IL Rte. 160 to Hemlock St., north on Hemlock to US Rte. 40, East on US Rte. 40 to IL Rte. 160. **Westbound:** Detour west on US Rte. 40 to Hemlock, south on Hemlock to Highland Rd., east on Highland Rd. to IL Rte. 160.

BE IT FURTHER RESOLVED that the Highland Jaycees assume full responsibility for the

direction, protection and regulation of the traffic during the time the detour is in effect.

BE IT FURTHER RESOLVED that police officers or authorized flaggers shall be positioned at each end of the closed section and at other points (such as intersections) as may be necessary to assist in directing traffic through the detour.

BE IT FURTHER RESOLVED, that police officers, flaggers and officials shall permit emergency vehicles in emergency situations to pass through the closed area as swiftly as is safe for all concerned.

BE IT FURTHER RESOLVED that all debris shall be removed by the Highland Jaycees prior to reopening the State Highway.

BE IT FURTHER RESOLVED that such signs, flags, barricades, etc., shall be used by the Highland Jaycees as may be approved by the Illinois Department of Transportation. These items shall be provided by the Highland Jaycees.

BE IT FURTHER RESOLVED that the closure and detour shall be marked according to the Illinois Manual on Uniform Traffic Control Devices.

BE IT FURTHER RESOLVED that an occasional break shall be made in the procession so that traffic may pass through. In any event, adequate provisions will be made for traffic on intersecting highways pursuant to conditions noted above. (Note: This paragraph is applicable when the Resolution pertains to a Parade or when no detour is required.)

BE IT FURTHER RESOLVED that the Highland Jaycees hereby agrees to assume all liabilities and pay all claims for any damage which shall be occasioned by the closing described above.

BE IT FURTHER RESOLVED, that the Highland Jaycees shall provide a comprehensive general liability insurance policy or an additional insured endorsement in the amount of \$100,000 per person and \$500,000 aggregate which has the Illinois Department of Transportation and its officials, employees, and agents as additional insureds and which protects them from all claims arising from the requested road

closing.

BE IT FURTHER RESOLVED that a copy of this Resolution be forwarded to the Illinois Department of Transportation to serve as a formal request for the permission sought in this resolution and to operate as part of the conditions of said permission.

ADOPTED by the City Council of the City of Highland on the ____ day of _____, 2024, and filed in the Office of the City Clerk this _____ day of _____, 2024.

AYES:

NOES:

ABSENT:

APPROVED:

Kevin B. Hemann
Mayor
City of Highland
Madison County, Illinois

ATTEST:

Barbara Bellm
City Clerk
City of Highland
Madison County, Illinois

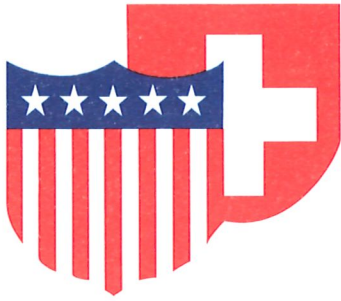

City of Highland

MEMO TO: Christopher Conrad, City Manager
FROM: Joe Gillespie, Director of Public Works
DATE: January 26, 2024
SUBJECT: 6th Street Reconstruction, PW-04-22
Recommendation for Approval of Joint Funding Agreement for
Construction Work, Section Numbers 19-00061-01-PV and 20-00061-02-RS

RECOMMENDATION

I recommend that you request council approval of a Joint Funding Agreement for Construction Work between the state of Illinois and the city of Highland, appropriating \$1,151,000 for the local share of the project as attached.

DISCUSSION

The project will correct settlement issues, reconstruct the pavement, construct new ADA curb ramps, sidewalks, add storm sewer and inlets, and curbing for the entire length of the project from Pine Street to Poplar Street.

We received Surface Transportation Program and State of Illinois funds in 2019 for this project. At that time, the estimated construction cost was \$1,258,000. Inflation has increased the construction costs by approximately \$670,000 to an estimated \$2,058,000. The federal and state funds will account for \$907,000 and the city is responsible for \$1,151,000.

FISCAL IMPACT

The project is funded by the Non Home Rule Sales Tax account for the City's portion.

CONCURRENCE

Recommended by: _____
Joe Gillespie
Joe Gillespie, Director of Public Works

Approved by: _____
Christopher Conrad
Christopher Conrad, City Manager



Joint Funding Agreement for Construction Work

LOCAL PUBLIC AGENCY

Local Public Agency: City of Highland; County: Madison; Section Number: 19-00061-01-PV; Fund Type: STU & STATE; ITEP, SRTS, HSIP Number(s): N/A; MPO Name: EWGCG; MPO TIP Number: 6985J-23; 7141F-24

Construction

State Job Number: C-98-015-23; Project Number: 6YZU(675)

- State-Let Construction (checked), Locally Let Construction, Construction Engineering, Utilities, Railroad Work

This Agreement is made and entered into between the above local public agency, hereinafter referred to as the "LPA" and the State of Illinois, acting by and through its Department of Transportation, hereinafter referred to as "STATE".

LOCATION

Local Street/Road Name: 6th Street; Key Route: FAU 8842; Length: 0.34 mile; Stationing: From 00.17 To 00.51

Location Termini: From Pine Street to Poplar Street

Current Jurisdiction: City of Highland; Existing Structure Number(s): N/A; Add Location/Remove buttons

PROJECT DESCRIPTION

Project is being combined with Section 20-00061-02-RS. Reconstruction on 6th Street and all work necessary to complete the project.

LOCAL PUBLIC AGENCY APPROPRIATION - REQUIRED FOR STATE LET CONTRACTS

By execution of this Agreement the LPA attests that sufficient moneys have been appropriated or reserved by resolution or ordinance to fund the LPA share of project costs.

METHOD OF FINANCING - (State-Let Contract Work Only)

Check One

- METHOD A - Lump Sum (80% of LPA Obligation)
METHOD B - Monthly Payments of due by the of each successive month.
METHOD C - LPA's Share BALANCE divided by estimated total cost multiplied by actual progress payment. (checked)

Failure to remit the payment(s) in a timely manner as required under Methods A, B, or C shall allow the **STATE** to internally offset, reduce, or deduct the arrearage from any payment or reimbursement due or about to become due and payable from the **STATE** to the **LPA** on this or any other contract. The **STATE** at its sole option, upon notice to the **LPA**, may place the debit into the Illinois Comptroller's Offset System (15 ILCS 405/10.05) or take such other and further action as may be required to recover the debt.

THE LPA AGREES:

1. To acquire in its name, or in the name of the **STATE** if on the **STATE** highway system, all right-of-way necessary for this project in accordance with the requirements of Titles II and III of the Uniform Relocation Assistance and Real Property Acquisition Policies Act of 1970, and established State policies and procedures. Prior to advertising for bids, the **LPA** shall certify to the **STATE** that all requirements of Titles II and III of said Uniform Act have been satisfied. The disposition of encroachments, if any, will be cooperatively determined by representatives of the **LPA**, the **STATE**, and the **FHWA** if required.
2. To provide for all utility adjustments and to regulate the use of the right-of-way of this improvement by utilities, public and private, in accordance with the current Utility Accommodation Policy for Local Public Agency Highway and Street Systems.
3. To provide for surveys and the preparation of plans for the proposed improvement and engineering supervision during construction of the proposed improvement.
4. To retain jurisdiction of the completed improvement unless specified otherwise by addendum (addendum should be accompanied by a location map). If the improvement location is currently under road district jurisdiction, a jurisdictional addendum is required.
5. To maintain or cause to be maintained the completed improvement (or that portion within its jurisdiction as established by addendum referred to in item 4 above) in a manner satisfactory to the **STATE** and the **FHWA**.
6. To comply with all applicable Executive Orders and Federal Highway Acts pursuant to the Equal Employment Opportunity and Nondiscrimination Regulations required by the U.S. Department of Transportation.
7. To maintain for a minimum of 3 years after final project close out by the **STATE**, adequate books, records and supporting documents to verify the amounts, recipients and uses of all disbursements of funds passing in conjunction with the contract. The contract and all books, records, and supporting documents related to the contract shall be available for review and audit by the Auditor General and the **STATE**. The **LPA** agrees to cooperate fully with any audit conducted by the Auditor General, the **STATE**, and to provide full access to all relevant materials. Failure to maintain the books, records, and supporting documents required by this section shall establish presumption in favor of the **STATE** for recovery of any funds paid by the **STATE** under the contract for which adequate books, records and supporting documentation are not available to support their purported disbursement.
8. To provide if required, for the improvement of any railroad-highway grade crossing and rail crossing protection within the limits of the proposed improvement.
9. To comply with Federal requirements or possibly lose (partial or total) Federal participation as determined by the **FHWA**.
10. To provide or cause to be provided all of the initial funding, equipment, labor, material, and services necessary to complete locally administered portions of the project.
11. (Railroad Related Work) The **LPA** is responsible for the payment of the railroad related expenses in accordance with the **LPA**/railroad agreement prior to requesting reimbursement from the **STATE**. Requests for reimbursement should be sent to the appropriate IDOT District Bureau of Local Roads and Streets Office. Engineer's Payment Estimates shall be in accordance with the Division of Cost.
12. Certifies to the best of its knowledge and belief that its officials:
 - a. are not presently debarred, suspended, proposed for debarment, declared ineligible or voluntarily excluded from covered transactions by any Federal department or agency;
 - b. have not within a three-year period preceding this agreement been convicted of or had a civil judgment rendered against them for commission of fraud or a criminal offense in connection with obtaining, attempting to obtain, or performing a public (Federal, State or local) transaction or contract under a public transaction; violation of Federal or State anti-trust statutes or commission of embezzlement, theft, forgery, bribery, falsification or destruction of records, making false statements receiving stolen property;
 - c. are not presently indicted for or otherwise criminally or civilly charged by a governmental entity (Federal, State, Local) with commission of any of the offenses enumerated in item (b) of this certification; and
 - d. have not within a three-year period preceding the agreement had one or more public transactions (Federal, State, Local) terminated for cause or default.
13. To include the certifications, listed in item 12 above, and all other certifications required by State statutes, in every contract, including procurement of materials and leases of equipment.
14. That execution of this agreement constitutes the **LPA**'s concurrence in the award of the construction contract to the responsible low bidder as determined by the **STATE**.
15. That for agreements exceeding \$100,000 in federal funds, execution of this agreement constitutes the **LPA**'s certification that:
 - a. No federal appropriated funds have been paid or will be paid, by or on behalf of the undersigned, to any person for influencing or attempting to influence an officer or employee of any agency, a member of congress, an officer or employee of congress, or any employee of a member of congress in connection with the awarding of any federal contract, the making of any cooperative agreement, and the extension, continuation, renewal, amendment or

modification of any Federal contract, grant, loan or cooperative agreement.

- b. If any funds other than federal appropriated funds have been paid or will be paid to any person for influencing or attempting to influence an officer or employee of any agency, a member of congress, an officer or employee of congress or an employee of a member of congress in connection with this federal contract, grant, loan, or cooperative agreement, the undersigned shall complete and submit standard form - LLL, "Disclosure Form to Report Lobbying", in accordance with its instructions.
- c. The LPA shall require that the language of this certification be included in the award documents for all subawards (including subcontracts, subgrants and contracts under grants, loans, and cooperative agreements), and that all subrecipients shall certify and disclose accordingly

16. To regulate parking and traffic in accordance with the approved project report.

17. To regulate encroachments on public rights-of-way in accordance with current Illinois Compiled Statutes.

18. To regulate the discharge of sanitary sewage into any storm water drainage system constructed with this improvement in accordance with the current Illinois Compiled Statutes.

THE STATE AGREES:

1. To provide such guidance, assistance, and supervision to monitor and perform audits to the extent necessary to assure validity of the LPA's certification of compliance with Title II and III Requirements.
2. To receive bids for construction of the proposed improvement when the plans have been approved by the STATE (and FHWA, if required) and to award a contract for construction of the proposed improvement after receipt of a satisfactory bid.
3. To provide all initial funding and payments to the contractor for construction work let by the STATE. The LPA will be invoiced for their share of contract costs per the method of payment selected under Method of Financing based on the Division of Costs shown on Addendum 2.
4. For agreements with federal and/or state funds in construction engineering, utility work and/or railroad work:
 - a. To reimburse the LPA for federal and/or state share on the basis of periodic billings, provided said billings contain sufficient cost information and show evidence of payments by the LPA;
 - b. To provide independent assurance sampling and furnish off-site material inspection and testing at sources normally visited by STATE inspectors for steel, cement, aggregate, structural steel, and other materials customarily tested by the STATE.

IT IS MUTUALLY AGREED:

1. Construction of the project will utilize domestic steel as required by Section 106.01 of the current edition of the Standard Specifications for Road and Bridge Construction and federal Buy America provisions
2. That this Agreement and the covenants contained herein shall become null and void in the event that the FHWA does not approve the proposed improvement for Federal-aid participation within one (1) year of the date of execution of this agreement.
3. This agreement shall be binding upon the parties, their successors, and assigns.
4. For contracts awarded by the LPA, the LPA shall not discriminate on the basis of race, color, national origin or sex in the award and performance of any USDOT - assisted contract or in the administration of its DBE program or the requirements of 49 CFR part 26. The LPA shall take all necessary and reasonable steps under 49 CFR part 26 to ensure nondiscrimination in the award and administration of USDOT - assisted contracts. The LPA's DBE program, as required by 49 CFR part 26 and as approved by USDOT, is incorporated by reference in this agreement. Upon notification to the recipient of its failure to carry out its approved program, the STATE may impose sanctions as provided for under part 26 and may, in appropriate cases, refer the matter for enforcement under 18 U.S. C 1001 and/or the Program Fraud Civil Remedies Act of 1986 (31 U.S.C 3801 et seq.). In the absence of a USDOT - approved LPA DBE Program or on state awarded contracts, this agreement shall be administered under the provisions of the STATE'S USDOT approved Disadvantaged Business Enterprise Program.
5. In cases where the STATE is reimbursing the LPA, obligation of the STATE shall cease immediately without penalty or further payment being required if, in any fiscal year, the Illinois General Assembly or applicable federal funding source fails to appropriate or otherwise make available funds for the work contemplated herein.
6. All projects for the construction of fixed works which are financed in whole or in part with funds provided by this agreement and/or amendment shall be subject to the Prevailing Wage Act (820 ILCS 130/0.01 et seq.) unless the provisions of the act exempt its application.

FISCAL RESPONSIBILITIES:

1. **Reimbursement Requests:** For reimbursement requests the LPA will submit supporting documentation with each invoice. Supporting documentation is defined as verification of payment, certified time sheets or summaries, vendor invoices, vendor receipts, cost plus fix fee invoice, progress report, personnel and direct cost summaries, and other documentation supporting the requested reimbursement amount (Form BLR 05621 should be used for consultant invoicing purposes). LPA invoice requests to the STATE will be submitted with sequential invoice numbers by project.
2. **Financial Integrity Review and Evaluation (FIRE) program:** LPA's and the STATE must justify continued federal funding on inactive projects. 23 CFR 630.106(a)(5) defines an inactive project as a project which no expenditures have been charged against Federal funds for the past twelve (12) months. To keep projects active, invoicing must occur a minimum of one time within any given twelve (12) month period. However, to ensure adequate processing time, the first invoice shall be submitted to

the **STATE** within six (6) months of the federal authorization date. Subsequent invoices will be submitted in intervals not to exceed six (6) months.

3. **Final Invoice:** The **LPA** will submit to the **STATE** a complete and detailed final invoice with applicable supporting documentation of all incurred costs, less previous payments, no later than twelve (12) months from the date of completion of work or from the date of the previous invoice, whichever occurs first. If a final invoice is not received within this time frame, the most recent invoice may be considered the final invoice and the obligation of the funds closed. Form BLR 05613 (Engineering Payment Record) is required to be submitted with the final invoice for engineering projects.
4. **Project Closeout:** The **LPA** shall provide the final report to the appropriate **STATE** district office within twelve (12) months of the physical completion date of the project so that the report may be audited and approved for payment. If the deadline cannot be met, a written explanation must be provided to the district prior to the end of the twelve (12) months documenting the reason and the new anticipated date of completion. If the extended deadline is not met, this process must be repeated until the project is closed. Failure to follow this process may result in the immediate close-out of the project and loss of further funding.
5. **Project End Date:** The period of performance (end date) for state and federal obligation purposes is five (5) years for projects under \$1,000,000 or seven (7) years for projects over \$1,000,000 from the execution date of the agreement.

Requests for time extensions and joint agreement amendments must be received and approved prior to expiration of the project end date. Failure to extend the end date may result in the immediate close-out of the project and loss of further funding.
6. **Single Audit Requirements:** If the **LPA** expends \$750,000 or more a year in federal financial assistance, they shall have an audit made in accordance with 2 CFR 200. **LPA's** expending less than \$750,000 a year shall be exempt from compliance. A copy of the audit report must be submitted to the **STATE** (IDOT's Office of Internal Audit, Room 201, 2300 South Dirksen Parkway, Springfield, Illinois, 62764) within 30 days after the completion of the audit, but no later than one year after the end of the **LPA's** fiscal year. The ALN number for all highway planning and construction activities is 20.205. Federal funds utilized for construction activities on projects let and awarded by the **STATE** (federal amounts shown as "Participating Construction" on Addendum 2) are not included in a **LPA's** calculation of federal funds expended by the **LPA** for Single Audit purposes..
7. **Federal Registration:** **LPA's** are required to register with the System for Award Management or SAM, which is a web-enabled government-wide application that collects, validates, stores, and disseminates business information about the federal government's trading partners in support of the contract award and the electronic payment processes. To register or renew, please use the following website: <https://www.sam.gov/SAM/>

ADDENDA

Additional information and/or stipulations are hereby attached and identified below as being a part of this agreement.

<input checked="" type="checkbox"/>	1.	Location Map
<input checked="" type="checkbox"/>	2.	Division of Cost
<input checked="" type="checkbox"/>	3.	Resolution*
<input type="checkbox"/>	4.	

*Appropriation and signature authority resolution must be in effect on, or prior to, the execution date of the agreement.

The LPA further agrees as a condition of payment, that it accepts and will comply with the applicable provisions set forth in this agreement and all Addenda indicated above.

APPROVED

Local Public Agency

Name of Official (Print or Type Name)

Mr. Kevin Hemann

Title of Official

Mayor

Signature

Date

--	--

The above signature certifies the agency's TIN number is 300003900 conducting business as a Governmental Entity.

DUNS Number 071998876

UEI _____

APPROVED

State of Illinois
Department of Transportation

Omer Osman, P.E., Secretary of Transportation

Date

--	--

By:

George A. Tapas, P.E., S.E., Engineer of Local Roads & Streets

Date

--	--

Stephen M. Travia, P.E., Director of Highways PI/Chief Engineer

Date

--	--

Yangsung Kim, Chief Counsel

Date

--	--

Vicki Wilson, Chief Fiscal Officer

Date

--	--

NOTE: A resolution authorizing the local official (or their delegate) to execute this agreement and appropriation of local funds is required to be attached as an addendum. The resolution must be approved prior to, or concurrently with, the execution of this agreement. If BLR 09110 or BLR 09120 are used to appropriate local matching funds, attach these forms to the signature authorization resolution.

Please check this box to open a fillable Resolution Form within this Addenda.

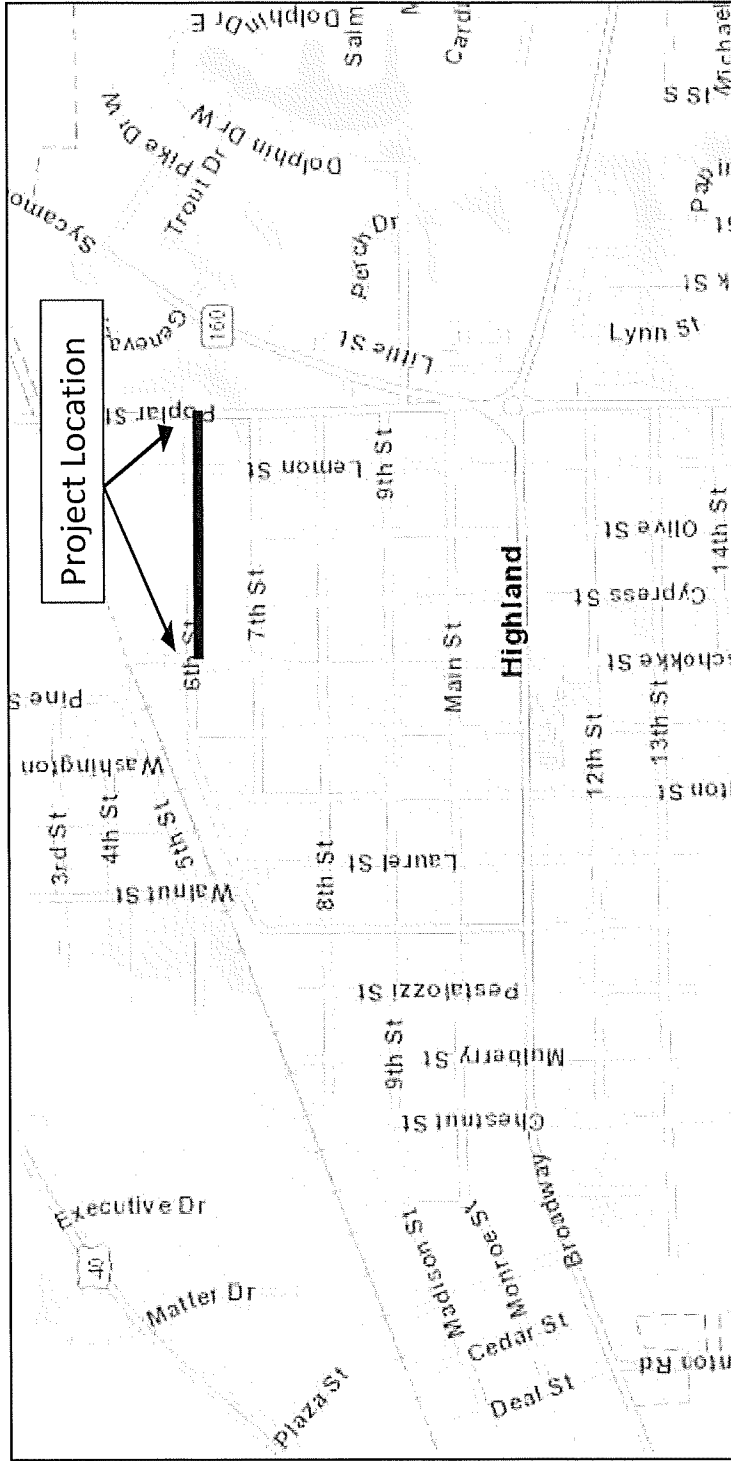

Addendum 1 - Location Map
 Highland
 19-00061-01-RS, 20-00061-02-RS
 C-98-015-23

ADDENDA NUMBER 2

Local Public Agency City of Highland	County Madison	Section Number 19-00061-01-PV	State Job Number C-98-015-23	Project Number 6YZU(675)
--	--------------------------	---	--	------------------------------------

DIVISION OF COST

Type of Work	Federal Funds			State Funds			Local Public Agency			Totals
	Fund Type	Amount	%	Fund Type	Amount	%	Fund Type	Amount	%	
Participating Construction	STU			STATE	\$61,000.00	*				\$61,000.00
Participating Construction	STU	\$846,000.00	**				Local	\$1,151,000.00	BAL	\$1,997,000.00
Total				Total	\$61,000.00		Total	\$1,151,000.00		\$2,058,000.00

If funding is not a percentage of the total place an asterisk (*) in the space provided for the percentage and explain below:

- * 100% State funds (formerly COVID funds) to be used first NTE \$61,000.00
- ** 80% STU Funds NTE \$846,000.00

NOTE: The costs shown in the Division of Cost table are approximate and subject to change. The final LPA share is dependent on the final Federal and State participation. The actual costs will be used in the final division of cost for billing and reimbursement.



Resolution for Improvement Under the Illinois Highway Code

Is this project a bondable capital improvement?

Yes No

Table with Resolution Type (Original), Resolution Number, and Section Number (19-00061-01-PV)

BE IT RESOLVED, by the Council of the City of Highland

Illinois that the following described street(s)/road(s)/structure be improved under the Illinois Highway Code. Work shall be done by Contract

For Roadway/Street Improvements:

Table with columns: Name of Street(s)/Road(s), Length (miles), Route, From, To. Row 1: 6th Street, 0.34, FAU 8842, Pine Street, Poplar Street

For Structures:

Table with columns: Name of Street(s)/Road(s), Existing Structure No., Route, Location, Feature Crossed

BE IT FURTHER RESOLVED,

1. That the proposed improvement shall consist of

Reconstruction on 6th Street and all work necessary to complete the project.

2. That there is hereby appropriated the sum of \$1,151,000.00

One Million One Hundred Fifty One Thousand Dollars (\$0.00) for the improvement of said section from the Local Public Agency's allotment of Motor Fuel Tax funds.

BE IT FURTHER RESOLVED, that the Clerk is hereby directed to transmit four (4) certified originals of this resolution to the district office of the Department of Transportation.

I, Barbara Bellm, Clerk in and for said City of Highland

do hereby certify the foregoing to be a true, perfect and complete original of a resolution adopted by

Council of Highland at a meeting held on February 05, 2024

IN TESTIMONY WHEREOF, I have hereunto set my hand and seal this Day of Month, Year

(SEAL, if required by the LPA)

Clerk Signature & Date

Approved Regional Engineer Signature & Date Department of Transportation



Resolution for Improvement Under the Illinois Highway Code

Is this project a bondable capital improvement?
[] Yes [] No

Table with Resolution Type (Original), Resolution Number, and Section Number (19-00061-01-PV)

BE IT RESOLVED, by the Council of the City of Highland Illinois that the following described street(s)/road(s)/structure be improved under the Illinois Highway Code. Work shall be done by Contract.

For Roadway/Street Improvements:

Table with columns: Name of Street(s)/Road(s), Length (miles), Route, From, To. Row 1: 6th Street, 0.34, FAU 8842, Pine Street, Poplar Street

For Structures:

Table with columns: Name of Street(s)/Road(s), Existing Structure No., Route, Location, Feature Crossed

BE IT FURTHER RESOLVED,

1. That the proposed improvement shall consist of

Reconstruction on 6th Street and all work necessary to complete the project.

2. That there is hereby appropriated the sum of \$1,151,000.00

One Million One Hundred Fifty One Thousand Dollars (\$0.00) for the improvement of said section from the Local Public Agency's allotment of Motor Fuel Tax funds.

BE IT FURTHER RESOLVED, that the Clerk is hereby directed to transmit four (4) certified originals of this resolution to the district office of the Department of Transportation.

I, Barbara Bellm City Clerk in and for said City

of Highland in the State aforesaid, and keeper of the records and files thereof, as provided by statute, do hereby certify the foregoing to be a true, perfect and complete original of a resolution adopted by

Council of Highland at a meeting held on February 05, 2024

IN TESTIMONY WHEREOF, I have hereunto set my hand and seal this 5th day of February 2024

(SEAL, if required by the LPA)

Clerk Signature & Date

Approved

Regional Engineer Signature & Date
Department of Transportation

LOCAL PUBLIC AGENCY

Local Public Agency		County	Section Number
City of Highland		Madison	19-00061-01-PV
Fund Type	ITEP, SRTS, HSIP Number(s)	MPO Name	MPO TIP Number
STU & STATE	N/A	EWGCG	6985J-23; 7141F-24

Construction

State Job Number	Project Number
C-98-015-23	6YZU(675)

State-Let Construction
 Locally Let Construction
 Construction Engineering
 Utilities
 Railroad Work

This Agreement is made and entered into between the above local public agency, hereinafter referred to as the "LPA" and the State of Illinois, acting by and through its Department of Transportation, hereinafter referred to as "STATE". The STATE and LPA jointly propose to improve the designated location as described below. The improvement shall be consulted in accordance with plans prepared by, or on behalf of the LPA and approved by the STATE using the STATE's policies and procedures approved and/or required by the Federal Highway Administration, hereinafter referred to as "FHWA".

LOCATION

Local Street/Road Name	Key Route	Length	Stationing	
6th Street	FAU 8842	0.34 mile	From	To
			00.17	00.51

Location Termini

From Pine Street to Poplar Street

Current Jurisdiction	Existing Structure Number(s)	Add Location
City of Highland	N/A	Remove

PROJECT DESCRIPTION

Project is being combined with Section 20-00061-02-RS Reconstruction on 6th Street and all work necessary to complete the project.

LOCAL PUBLIC AGENCY APPROPRIATION - REQUIRED FOR STATE LET CONTRACTS

By execution of this Agreement the LPA attests that sufficient moneys have been appropriated or reserved by resolution or ordinance to fund the LPA share of project costs. A copy of the authorizing resolution or ordinance is attached as an addendum.

METHOD OF FINANCING - (State-Let Contract Work Only)

Check One

- METHOD A - Lump Sum** (80% of LPA Obligation _____)
 Lump Sum Payment - Upon award of the contract for this improvement, the LPA will pay the STATE within thirty (30) calendar days of billing, in lump sum, an amount equal to 80% of the LPA's estimated obligation incurred under this agreement. The LPA will pay to the STATE the remainder of the LPA's obligation (including any nonparticipating costs) in a lump sum within thirty (30) calendar days of billing in a lump sum, upon completion of the project based on final costs.
- METHOD B - _____ Monthly Payments of _____** due by the _____ of each successive month.
 Monthly Payments - Upon award of the contract for this improvement, the LPA will pay to the STATE a specified amount each month for an estimated period of months, or until 80% of the LPA's estimated obligation under the provisions of the agreement has been paid. The LPA will pay to the STATE the remainder of the LPA's obligation (including any nonparticipating costs) in a lump sum, upon completion of the project based upon final costs.
- METHOD C - LPA's Share _____ BALANCE _____** divided by estimated total cost multiplied by actual progress payment.
 Progress Payments - Upon receipt of the contractor's first and subsequent progressive bills for this improvement, the LPA will pay to the STATE within thirty (30) calendar days of receipt, an amount equal to the LPA's share of the construction cost divided by the estimated total cost multiplied by the actual payment (appropriately adjust for nonparticipating costs) made to the contractor until the entire obligation incurred under this agreement has been paid.

Failure to remit the payment(s) in a timely manner as required under Methods A, B, or C shall allow the **STATE** to internally offset, reduce, or deduct the arrearage from any payment or reimbursement due or about to become due and payable from the **STATE** to the **LPA** on this or any other contract. The **STATE** at its sole option, upon notice to the **LPA**, may place the debit into the Illinois Comptroller's Offset System (15 ILCS 405/10.05) or take such other and further action as may be required to recover the debt.

THE LPA AGREES:

1. To acquire in its name, or in the name of the **STATE** if on the **STATE** highway system, all right-of-way necessary for this project in accordance with the requirements of Titles II and III of the Uniform Relocation Assistance and Real Property Acquisition Policies Act of 1970, and established State policies and procedures. Prior to advertising for bids, the **LPA** shall certify to the **STATE** that all requirements of Titles II and III of said Uniform Act have been satisfied. The disposition of encroachments, if any, will be cooperatively determined by representatives of the **LPA**, the **STATE**, and the **FHWA** if required.
2. To provide for all utility adjustments and to regulate the use of the right-of-way of this improvement by utilities, public and private, in accordance with the current Utility Accommodation Policy for Local Public Agency Highway and Street Systems.
3. To provide for surveys and the preparation of plans for the proposed improvement and engineering supervision during construction of the proposed improvement.
4. To retain jurisdiction of the completed improvement unless specified otherwise by addendum (addendum should be accompanied by a location map). If the improvement location is currently under road district jurisdiction, a jurisdictional addendum is required.
5. To maintain or cause to be maintained the completed improvement (or that portion within its jurisdiction as established by addendum referred to in item 4 above) in a manner satisfactory to the **STATE** and the **FHWA**.
6. To comply with all applicable Executive Orders and Federal Highway Acts pursuant to the Equal Employment Opportunity and Nondiscrimination Regulations required by the U.S. Department of Transportation.
7. To maintain for a minimum of 3 years after final project close out by the **STATE**, adequate books, records and supporting documents to verify the amounts, recipients and uses of all disbursements of funds passing in conjunction with the contract. The contract and all books, records, and supporting documents related to the contract shall be available for review and audit by the Auditor General and the **STATE**. The **LPA** agrees to cooperate fully with any audit conducted by the Auditor General, the **STATE**, and to provide full access to all relevant materials. Failure to maintain the books, records, and supporting documents required by this section shall establish presumption in favor of the **STATE** for recovery of any funds paid by the **STATE** under the contract for which adequate books, records and supporting documentation are not available to support their purported disbursement.
8. To provide if required, for the improvement of any railroad-highway grade crossing and rail crossing protection within the limits of the proposed improvement.
9. To comply with Federal requirements or possibly lose (partial or total) Federal participation as determined by the **FHWA**.
10. To provide or cause to be provided all of the initial funding, equipment, labor, material, and services necessary to complete locally administered portions of the project.
11. (Railroad Related Work) The **LPA** is responsible for the payment of the railroad related expenses in accordance with the LPA/ railroad agreement prior to requesting reimbursement from the **STATE**. Requests for reimbursement should be sent to the appropriate IDOT District Bureau of Local Roads and Streets Office. Engineer's Payment Estimates shall be in accordance with the Division of Cost.
12. Certifies to the best of its knowledge and belief that it's officials:
 - a. are not presently debarred, suspended, proposed for debarment, declared ineligible or voluntarily excluded from covered transactions by any Federal department or agency;
 - b. have not within a three-year period preceding this agreement been convicted of or had a civil judgment rendered against them for commission of fraud or a criminal offense in connection with obtaining, attempting to obtain, or performing a public (Federal, State or local) transaction or contract under a public transaction; violation of Federal or State anti-trust statutes or commission of embezzlement, theft, forgery, bribery, falsification or destruction of records, making false statements receiving stolen property;
 - c. are not presently indicted for or otherwise criminally or civilly charged by a governmental entity (Federal, State, Local) with commission of any of the offenses enumerated in item (b) of this certification; and
 - d. have not within a three-year period preceding the agreement had one or more public transactions (Federal, State, Local) terminated for cause or default.
13. To include the certifications, listed in item 12 above, and all other certifications required by State statutes, in every contract, including procurement of materials and leases of equipment.
14. That execution of this agreement constitutes the **LPA's** concurrence in the award of the construction contract to the responsible low bidder as determined by the **STATE**.
15. That for agreements exceeding \$100,000 in federal funds, execution of this agreement constitutes the LPA's certification that:
 - a. No federal appropriated funds have been paid or will be paid, by or on behalf of the undersigned, to any person for influencing or attempting to influence an officer or employee of any agency, a member of congress, an officer or employee of congress, or any employee of a member of congress in connection with the awarding of any federal contract, the making of any cooperative agreement, and the extension, continuation, renewal, amendment or

modification of any Federal contract, grant, loan or cooperative agreement.

- b. If any funds other than federal appropriated funds have been paid or will be paid to any person for influencing or attempting to influence an officer or employee of any agency, a member of congress, an officer or employee of congress or an employee of a member of congress in connection with this federal contract, grant, loan, or cooperative agreement, the undersigned shall complete and submit standard form - LLL, "Disclosure Form to Report Lobbying", in accordance with its instructions.
- c. The LPA shall require that the language of this certification be included in the award documents for all subawards (including subcontracts, subgrants and contracts under grants, loans, and cooperative agreements), and that all subrecipients shall certify and disclose accordingly

16. To regulate parking and traffic in accordance with the approved project report.

17. To regulate encroachments on public rights-of-way in accordance with current Illinois Compiled Statutes.

18. To regulate the discharge of sanitary sewage into any storm water drainage system constructed with this improvement in accordance with the current Illinois Compiled Statutes.

THE STATE AGREES:

1. To provide such guidance, assistance, and supervision to monitor and perform audits to the extent necessary to assure validity of the **LPA's** certification of compliance with Title II and III Requirements.
2. To receive bids for construction of the proposed improvement when the plans have been approved by the **STATE** (and **FHWA**, if required) and to award a contract for construction of the proposed improvement after receipt of a satisfactory bid.
3. To provide all initial funding and payments to the contractor for construction work let by the **STATE**. The **LPA** will be invoiced for their share of contract costs per the method of payment selected under Method of Financing based on the Division of Costs shown on Addendum 2.
4. For agreements with federal and/or state funds in construction engineering, utility work and/or railroad work:
 - a. To reimburse the **LPA** for federal and/or state share on the basis of periodic billings, provided said billings contain sufficient cost information and show evidence of payments by the **LPA**;
 - b. To provide independent assurance sampling and furnish off-site material inspection and testing at sources normally visited by **STATE** inspectors for steel, cement, aggregate, structural steel, and other materials customarily tested by the **STATE**.

IT IS MUTUALLY AGREED:

1. Construction of the project will utilize domestic steel as required by Section 106.01 of the current edition of the Standard Specifications for Road and Bridge Construction and federal Buy America provisions
2. That this Agreement and the covenants contained herein shall become null and void in the event that the **FHWA** does not approve the proposed improvement for Federal-aid participation within one (1) year of the date of execution of this agreement.
3. This agreement shall be binding upon the parties, their successors, and assigns.
4. For contracts awarded by the **LPA**, the **LPA** shall not discriminate on the basis of race, color, national origin or sex in the award and performance of any USDOT - assisted contract or in the administration of its DBE program or the requirements of 49 CFR part 26. The **LPA** shall take all necessary and reasonable steps under 49 CFR part 26 to ensure nondiscrimination in the award and administration of USDOT - assisted contracts. The **LPA's** DBE program, as required by 49 CFR part 26 and as approved by USDOT, is incorporated by reference in this agreement. Upon notification to the recipient of its failure to carry out its approved program, the **STATE** may impose sanctions as provided for under part 26 and may, in appropriate cases, refer the matter for enforcement under 18 U.S. C 1001 and/or the Program Fraud Civil Remedies Act of 1986 (31 U.S.C 3801 et seq.). In the absence of a USDOT - approved **LPA** DBE Program or on **state** awarded contracts, this agreement shall be administered under the provisions of the **STATE'S** USDOT approved Disadvantaged Business Enterprise Program.
5. In cases where the **STATE** is reimbursing the **LPA**, obligation of the **STATE** shall cease immediately without penalty or further payment being required if, in any fiscal year, the Illinois General Assembly or applicable federal funding source fails to appropriate or otherwise make available funds for the work contemplated herein.
6. All projects for the construction of fixed works which are financed in whole or in part with funds provided by this agreement and/or amendment shall be subject to the Prevailing Wage Act (820 ILCS 130/0.01 et seq.) unless the provisions of the act exempt its application.

FISCAL RESPONSIBILITIES:

1. **Reimbursement Requests:** For reimbursement requests the **LPA** will submit supporting documentation with each invoice. Supporting documentation is defined as verification of payment, certified time sheets or summaries, vendor invoices, vendor receipts, cost plus fix fee invoice, progress report, personnel and direct cost summaries, and other documentation supporting the requested reimbursement amount (Form BLR 05621 should be used for consultant invoicing purposes). **LPA** invoice requests to the **STATE** will be submitted with sequential invoice numbers by project.
2. **Financial Integrity Review and Evaluation (FIRE) program:** **LPA's** and the **STATE** must justify continued federal funding on inactive projects. 23 CFR 630.106(a)(5) defines an inactive project as a project which no expenditures have been charged against Federal funds for the past twelve (12) months. To keep projects active, invoicing must occur a minimum of one time within any given twelve (12) month period. However, to ensure adequate processing time, the first invoice shall be submitted to

the **STATE** within six (6) months of the federal authorization date. Subsequent invoices will be submitted in intervals not to exceed six (6) months.

3. **Final Invoice:** The **LPA** will submit to the **STATE** a complete and detailed final invoice with applicable supporting documentation of all incurred costs, less previous payments, no later than twelve (12) months from the date of completion of work or from the date of the previous invoice, whichever occurs first. If a final invoice is not received within this time frame, the most recent invoice may be considered the final invoice and the obligation of the funds closed. Form BLR 05613 (Engineering Payment Record) is required to be submitted with the final invoice for engineering projects.
4. **Project Closeout:** The **LPA** shall provide the final report to the appropriate **STATE** district office within twelve (12) months of the physical completion date of the project so that the report may be audited and approved for payment. If the deadline cannot be met, a written explanation must be provided to the district prior to the end of the twelve (12) months documenting the reason and the new anticipated date of completion. If the extended deadline is not met, this process must be repeated until the project is closed. Failure to follow this process may result in the immediate close-out of the project and loss of further funding.
5. **Project End Date:** The period of performance (end date) for state and federal obligation purposes is five (5) years for projects under \$1,000,000 or seven (7) years for projects over \$1,000,000 from the execution date of the agreement.

Requests for time extensions and joint agreement amendments must be received and approved prior to expiration of the project end date. Failure to extend the end date may result in the immediate close-out of the project and loss of further funding.

6. **Single Audit Requirements:** If the **LPA** expends \$750,000 or more a year in federal financial assistance, they shall have an audit made in accordance with 2 CFR 200. **LPA's** expending less than \$750,000 a year shall be exempt from compliance. A copy of the audit report must be submitted to the **STATE** (IDOT's Office of Internal Audit, Room 201, 2300 South Dirksen Parkway, Springfield, Illinois, 62764) within 30 days after the completion of the audit, but no later than one year after the end of the LPA's fiscal year. The ALN number for all highway planning and construction activities is 20.205. Federal funds utilized for construction activities on projects let and awarded by the **STATE** (federal amounts shown as "Participating Construction" on Addendum 2) are not included in a **LPA's** calculation of federal funds expended by the LPA for Single Audit purposes..
7. **Federal Registration:** **LPA's** are required to register with the System for Award Management or SAM, which is a web-enabled government-wide application that collects, validates, stores, and disseminates business information about the federal government's trading partners in support of the contract award and the electronic payment processes. To register or renew, please use the following website: <https://www.sam.gov/SAM/>

ADDENDA

Additional information and/or stipulations are hereby attached and identified below as being a part of this agreement.

<input checked="" type="checkbox"/>	1.	Location Map
<input checked="" type="checkbox"/>	2.	Division of Cost
<input checked="" type="checkbox"/>	3.	Resolution*
<input type="checkbox"/>	4.	

*Appropriation and signature authority resolution must be in effect on, or prior to, the execution date of the agreement.

The **LPA** further agrees as a condition of payment, that it accepts and will comply with the applicable provisions set forth in this agreement and all Addenda indicated above.

APPROVED

Local Public Agency

Name of Official (Print or Type Name)

Mr. Kevin Hemann

Title of Official

Mayor

Signature

Date

[Signature and Date boxes]

The above signature certifies the agency's TIN number is 300003900 conducting business as a Governmental Entity.

DUNS Number 071998876

UEI _____

APPROVED

State of Illinois
Department of Transportation

Omer Osman, P.E., Secretary of Transportation

Date

[Signature and Date boxes]

By:
George A. Tapas, P.E., S.E., Engineer of Local Roads & Streets

Date

[Signature and Date boxes]

Stephen M. Travia, P.E., Director of Highways PI/Chief Engineer

Date

[Signature and Date boxes]

Yangsu Kim, Chief Counsel

Date

[Signature and Date boxes]

Vicki Wilson, Chief Fiscal Officer

Date

[Signature and Date boxes]

NOTE: A resolution authorizing the local official (or their delegate) to execute this agreement and appropriation of local funds is required to be attached as an addendum. The resolution must be approved prior to, or concurrently with, the execution of this agreement. If BLR 09110 or BLR 09120 are used to appropriate local matching funds, attach these forms to the signature authorization resolution.

Please check this box to open a fillable Resolution Form within this Addenda.



Addendum 1 - Location Map
Highland
19-00061-01-RS, 20-00061-02-RS
C-98-015-23

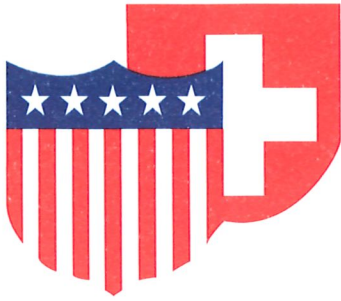

City of Highland

MEMO TO: Christopher Conrad, City Manager
FROM: Joe Gillespie, Director of Public Works
DATE: January 26, 2024
SUBJECT: Matter Drive Reconstruction, PW-05-21
Recommendation for Approval of Expenditure of
Rebuild Illinois and Motor Fuel Tax Funds

RECOMMENDATION

I recommend that you request council approval to use Illinois Rebuild Funds and Motor Fuel Tax funds, for the City's portion of the project as attached.

DISCUSSION

We successfully received an economic development program grant from the state of Illinois in conjunction with the Trow plant expansion. The grant pays up to \$510,000 for construction with the remaining from the Rebuild Illinois funds. We received \$653,701.14 in Rebuild Illinois Funds from the state of Illinois through our MFT account. The resolution document is requesting the use of those funds and \$58,234.95 from our MFT account. These amounts will pay for the city's portion of the construction and engineering for the project.

FISCAL IMPACT

We reserved the Rebuild Illinois Funds specifically for this work.

CONCURRENCE

Recommended by: _____

Joe Gillespie, Director of Public Works

Approved by: _____

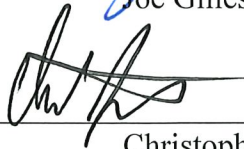

Christopher Conrad, City Manager



**Request for Expenditure/Authorization
of Motor Fuel Tax Funds**

Local Public Agency Highland	Type City	County Madison	Section Number 21-00073-00-PV
---------------------------------	--------------	-------------------	----------------------------------

I hereby request authorization to expend Motor Fuel Tax Funds as indicated below:

Purpose	Motor Fuel Tax Amount	Rebuild Illinois Amount
County Engineer/Superintendent Salary & Expenses		n/a
Contract Construction		\$480,718.09
Day Labor Construction		
Engineering	\$58,234.95	\$172,983.05
Engineering Investigations		
IMRF/Social Security		n/a
Maintenance		
Maintenance Engineering		
Obligation Retirement		n/a
Other		
Right-of-Way (Itemized on 2nd page)		
TOTAL	\$58,234.95	\$653,701.14

Comments

Local Public Agency Official Signature & Date

Title

Mayor

Approved

Regional Engineer Signature & Date
Department of Transportation

Department of Transportation Use

Entered By	Date

Itemization of Right-of-Way Request

Location of Property			Property Owner	Acres Right-of- Way	Relocation Costs	Cost of Land Acquired	Cost of Damage to Land not Acquired	Total
Street/Road	Parcel Number	Address of Property Involved						
							TOTAL	
Add Item								

RESOLUTION NO. _____

**RESOLUTION AUTHORIZING APPROVAL OF EXPENDITURE OF
ECONOMIC DEVELOPMENT FUNDS, REBUILD ILLINOIS FUNDS,
AND MOTOR FUEL TAX FUNDS FOR
CONSTRUCTION OF MATTER DRIVE, PW-05-21**

WHEREAS, the City of Highland, Madison County, Illinois (hereinafter "City"), is a non-home rule municipality duly established, existing and operating in accordance with the provisions of the Illinois Municipal Code (Section 5/1-1-1 *et seq.* of Chapter 65 of the Illinois Compiled Statutes); and

WHEREAS, the Director of Public Works has informed the City Council that the City received an economic development grant in the amount of \$510,000.00 for construction of Matter Drive; and

WHEREAS, the Director of Public Works has informed the City Council that the City received \$653,701.14 in Rebuild Illinois funds for construction of Matter Drive; and

WHEREAS, the Director of Public Works has informed the City Council that the City may use \$58,234.95 from Motor Fuel Tax funds for engineering related to construction of Matter Drive; and

WHEREAS, the City has determined it would be in the best interests of public health, safety, general welfare, and economic welfare to authorize the City to spend \$711,936.09 under the Illinois Department of Transportation ("IDOT") Request for Expenditure/Authorization of Motor Fuel Tax Funds for construction and engineering of Matter Drive (*See Exhibit A*); and

WHEREAS, the City authorizes and directs the City Manager and/or Mayor to execute any documents necessary to spend \$711,936.09 under the IDOT Request for Expenditure/Authorization of Motor Fuel Tax Funds for construction and engineering of Matter Drive (*See Exhibit A*).

NOW, THEREFORE, BE IT RESOLVED, by the Mayor and City Council of the City of Highland, Illinois, as follows:

- Section 1.* The foregoing recitals are incorporated herein as findings of the City Council of the City of Highland, Illinois.
- Section 2.* The expenditure of \$711,936.09 under the IDOT Request for Expenditure/Authorization of Motor Fuel Tax Funds for construction and engineering of Matter Drive (*See Exhibit A*) is approved.
- Section 3.* The City Manager and/or Mayor is directed and authorized, on behalf

of the City of Highland, to execute any documents necessary to give effect to this Resolution (*See Exhibit A*).

Section 4. This Resolution shall be known as Resolution No. _____, and shall be effective upon its passage and approval in accordance with Illinois law.

Passed by the City Council of the City of Highland, Illinois, and deposited and filed in the Office of the City Clerk, on the ____ day of _____, 2024, the vote being taken by ayes and noes, and entered upon the legislative records, as follows:

AYES:

NOES:

APPROVED:

Kevin B. Hemann
Mayor
City of Highland
Madison County, Illinois

ATTEST:

Barbara Bellm
City Clerk
City of Highland
Madison County, Illinois



**Request for Expenditure/Authorization
of Motor Fuel Tax Funds**

Local Public Agency Highland	Type City	County Madison	Section Number 21-00073-00-PV
---------------------------------	--------------	-------------------	----------------------------------

I hereby request authorization to expend Motor Fuel Tax Funds as indicated below:

Purpose	Motor Fuel Tax Amount	Rebuild Illinois Amount
County Engineer/Superintendent Salary & Expenses		n/a
Contract Construction		\$480,718.09
Day Labor Construction		
Engineering	\$58,234.95	\$172,983.05
Engineering Investigations		
IMRF/Social Security		n/a
Maintenance		
Maintenance Engineering		
Obligation Retirement		n/a
Other		
Right-of-Way (Itemized on 2nd page)		
TOTAL	\$58,234.95	\$653,701.14

Comments

Local Public Agency Official Signature & Date

Title

Mayor

Approved

Regional Engineer Signature & Date
Department of Transportation

Department of Transportation Use

Entered By

Date

Itemization of Right-of-Way Request

Location of Property			Property Owner	Acres Right-of-Way	Relocation Costs	Cost of Land Acquired	Cost of Damage to Land not Acquired	Total
Street/Road	Parcel Number	Address of Property Involved						
							TOTAL	

Add Item



City of Highland

Memo to: Christopher Conrad, City Manager
From: Joe Gillespie, Director of Public Works
Date: January 26, 2024
Subject: Motor Fuel Tax (MFT) Section 25-00000-00-GM
Recommendation for Approval

RECOMMENDATION

I recommend that you request council approval to adopt the 2024-2025 Motor Fuel Tax Resolution and Municipal Estimate of Maintenance Costs for general maintenance materials for \$390,000 as attached.

DISCUSSION

The State requires us to pass a resolution appropriating the estimated funds. The Municipal Estimate of Maintenance Costs form outlines our intended purchases for materials and is subject to their approval. It is similar to previous years.

FISCAL IMPACT

The materials are funded through Motor Fuel Tax from the state of Illinois.

CONCURRENCE

Recommended by: Joe Gillespie
Joe Gillespie, Director of Public Works

Approved by: Christopher Conrad
Christopher Conrad, City Manager



District	County	Resolution Number	Resolution Type	Section Number
8	Madison		Original	25-00000-00-GM

BE IT RESOLVED, by the Council of the City of Highland Illinois that there is hereby appropriated the sum of _____

Three hundred ninety thousand Dollars (\$390,000.00)

of Motor Fuel Tax funds for the purpose of maintaining streets and highways under the applicable provisions of Illinois Highway Code from

05/01/24 to 04/30/25
Beginning Date Ending Date

BE IT FURTHER RESOLVED, that only those operations as listed and described on the approved Estimate of Maintenance Costs, including supplemental or revised estimates approved in connection with this resolution, are eligible for maintenance with Motor Fuel Tax funds during the period as specified above.

BE IT FURTHER RESOLVED, that City of Highland shall submit within three months after the end of the maintenance period as stated above, to the Department of Transportation, on forms available from the Department, a certified statement showing expenditures and the balances remaining in the funds authorized for expenditure by the Department under this appropriation, and

BE IT FURTHER RESOLVED, that the Clerk is hereby directed to transmit four (4) certified originals of this resolution to the district office of the Department of Transportation.

I Barbara Bellm City Clerk in and for said City

of Highland in the State of Illinois, and keeper of the records and files thereof, as

provided by statute, do hereby certify the foregoing to be a true, perfect and complete copy of a resolution adopted by the

Council of Highland at a meeting held on 02/05/24

IN TESTIMONY WHEREOF, I have hereunto set my hand and seal this _____ day of _____ Month, Year

(SEAL, if required by the LPA)

Clerk Signature & Date

APPROVED

Regional Engineer Signature & Date
Department of Transportation



Local Public Agency General Maintenance

Submittal Type Original

Estimate of Maintenance Costs

District 8 Estimate of Cost For Municipality

Local Public Agency	County	Section Number	Maintenance Period Beginning	Ending
City of Highland	Madison	25-00000-00-GM	05/01/24	04/30/25

Maintenance Items

Maintenance Operation	Maint Eng Category	Insp. Req.	Material Categories/ Point of Delivery or Work Performed by an Outside Contractor	Unit	Quantity	Unit Cost	Cost	Total Maintenance Operation Cost
Snow Control			Treated Rock Salt	TON	1,000	\$76.00	\$76,000.00	
			Grit (CM-13 slag)	TON	25	\$16.00	\$400.00	\$76,400.00
Pavement Replacement			PCC Pvmt, 6-bag	CY	85	\$155.00	\$13,175.00	
			PCC Pvmt, 7-bag	CY	65	\$175.00	\$11,375.00	
			Reinforcing Bars, #6	LF	1,000	\$3.00	\$3,000.00	
Pavement Patching			Expansion Material	LF	450	\$1.10	\$495.00	\$28,045.00
			Bituminous Cold Patch	TON	40	\$150.00	\$6,000.00	
			Hot Mix Asphalt	TON	200	\$80.00	\$16,000.00	
			Hot Pour Tar (IL spec)	LB	6,750	\$0.80	\$5,400.00	\$27,400.00
Signs			Stop, St., No Prk, Spd Lmt	EA	240	\$65.00	\$15,600.00	\$15,600.00
Base			CA-6 Aggregate	TON	1,000	\$13.00	\$13,000.00	
			CA-7 Aggregate	TON	400	\$18.00	\$7,200.00	\$20,200.00
Seal Coat Opr.			MC-800	TON	40	\$1,400.00	\$56,000.00	
			HFRS-2	TON	120	\$700.00	\$84,000.00	
			CM-13 slag Furn/Del	TON	1,400	\$27.00	\$37,800.00	
			CM-13 slag Haul/Spred	TON	1,400	\$27.00	\$37,800.00	\$215,600.00
Pavement Marking			Yellow Paint	GAL	25	\$35.00	\$875.00	
			White Paint	GAL	120	\$35.00	\$4,200.00	\$5,075.00
Total Operation Cost								\$388,320.00

Estimate of Maintenance Costs Summary

	MFT Funds	RBI Funds	Other Funds	Estimated Costs
Maintenance				
Local Public Agency Labor				
Local Public Agency Equipment				
Materials/Contracts(Non Bid Items)	\$76,120.00			\$76,120.00
Materials/Deliver & Install/Materials Quotations (Bid Items)				
Formal Contract (Bid Items)	\$312,200.00			\$312,200.00
Maintenance Total	\$388,320.00			\$388,320.00

Estimated Maintenance Eng Costs Summary

	MFT Funds	RBI Funds	Other Funds	Total Est Costs
Maintenance Engineering				
Preliminary Engineering				
Engineering Inspection				
Material Testing				
Advertising				
Bridge Inspection Engineering				
Maintenance Engineering Total				
Total Estimated Maintenance	\$388,320.00			\$388,320.00

Estimate of Maintenance Costs

Submittal Type

Maintenance Period

Beginning

Ending

Local Public Agency

County

Section

Remarks

SUBMITTED

Local Public Agency Official Signature & Date

Title

County Engineer/Superintendent of Highways Signature & Date

APPROVED

Regional Engineer Signature & Date

Department of Transportation

IDOT Department Use Only

Received Location

Received Date

Additional Location?

WMFT Entry By

Entry Date



City of Highland

MEMO TO: Christopher Conrad, City Manager
FROM: Joe Gillespie, Director of Public Works
DATE: February 1, 2024
SUBJECT: Declaring Surplus Property for Street and Alley
Flink Stainless Steel Salt Spreader
Recommendation for Surplus Property Approval

RECOMMENDATION

I recommend you request council approval to declare a Flink salt spreader as surplus property.

DISCUSSION

The division received approval in December to surplus a dump truck. The salt spreader for that truck is no longer useful. We have received a new truck and spreader. A buyer is interested in the truck and spreader together.

Make: Flink
Dimensions: 6.4 Cubic Yard, length 10-foot
Construction: V-box hopper, chain driven, stainless steel construction
Serial No.: 924XXX (the last digits of the number are unreadable)

FISCAL IMPACT

Funds from the sale will go into the division account.

CONCURRENCE

Recommended by: _____
Joe Gillespie, Director of Public Works

Approved by: _____
Christopher Conrad, City Manager

ORDINANCE NO. _____

**ORDINANCE DECLARING PERSONAL PROPERTY OF THE CITY OF HIGHLAND
SURPLUS AND AUTHORIZING ITS SALE AND/OR DISPOSAL, SPECIFICALLY A
SALT SPREADER**

WHEREAS, the City of Highland, Madison County, Illinois (hereinafter “City”), is a non-home rule municipality duly established, existing and operating in accordance with the provisions of the Illinois Municipal Code (Section 5/1-1-1 et seq. of Chapter 65 of the Illinois Compiled Statutes); and

WHEREAS, 65 ILCS 5/11-76-4 provides that whenever a municipality in the state of Illinois owns any personal property which, in the opinion of a simple majority of the corporate authorities then holding office, is no longer necessary or useful to, or in the best interests of the municipality to keep, a majority of the corporate authorities at any regular or special meeting called for that purpose, may: (1) by Ordinance authorize the sale of such personal property in whatever manner they designate with or without advertising the sale; or (2) may authorize any municipal officer to convert that personal property to the use of the City; or (3) may authorize any municipal officer to convey or turn in any specified article of personal property as part payment on a new purchase of any similar article; and

WHEREAS, the City currently owns personal property, including:

Salt Spreader	
Manufacturer: Flink	V-box hopper with chain driven
Year: Unknown	Stainless steel construction
Dimensions/size: 10’ length, 6.4 cy capacity	Serial number beginning 924 . . .

(“Salt Spreader”); and

WHEREAS, in the opinion of this City Council, the Salt Spreader is no longer necessary or useful to, or in the best interests of the City to retain, and should be declared surplus personal property; and

WHEREAS, the City Manager has informed the City Council the Salt Spreader will be sold for the highest value possible, or disposed of if they are deemed to have little or no value; and

WHEREAS, City has determined the City Manager, or his designee, is permitted to sell the surplus personal property, specifically the Salt Spreader, for the maximum value that can be obtained, or to dispose of the surplus personal property where appropriate, to be determined solely by the City Manager, or his designee; and

WHEREAS, City has determined it to be in the best interest of public health, safety, general welfare and economic welfare to declare the aforementioned personal property surplus, and sell and/or dispose of the same.

NOW, THEREFORE, BE IT ORDAINED by the City Council of the City of Highland, Illinois, as follows:

Section 1. The foregoing recitals are incorporated herein as findings of the City Council of the City of Highland, Illinois.

Section 2. The City personal property, specifically the Salt Spreader, is hereby declared no longer useful to the City or necessary for City purposes, that the City personal property is declared surplus, and that it is in the best interest of the City to sell and/or dispose of the same.

Section 3. The City Manager, or his designee, is directed and authorized to sell and/or dispose of the surplus personal property, as the City Manager, or his designee, sees fit.

Section 4. The City Manager, or his designee, is directed and authorized to sell the surplus personal property for the maximum value that can be obtained, or to dispose of the surplus personal property where appropriate, to be determined solely by the City Manager, or his designee.

Section 5. This Ordinance shall be known as Ordinance No. _____ and shall be in full force and effect from and after its passage, approval, and publication in pamphlet form as provided by law.

Passed by the City Council and approved by the Mayor of the city of Highland, Illinois and deposited and filed in the office of the City Clerk on the _____ day of _____, 2024, the vote being taken by ayes and noes and entered upon the legislative record as follows:

AYES:

NOES:

ABSENT:

APPROVED:

Kevin Hemann, Mayor
City of Highland
Madison County, Illinois

ATTEST:

Barbara Bellm, City Clerk
City of Highland
Madison County, Illinois



HIGHLAND

PARKS & RECREATION... The *FUN* Theory!

To: Chris Conrad, City Manager

From: Mark Rosen, Director of Parks & Recreation
Brad Koehnemann, Parks & Athletics Mgr.
Ryan Hummert, Natural Resources Mgr.

Date: February 5, 2024

Subject: Sole Source Truck Purchase

Recommendation

I am recommending city council approval for a sole source quote to purchase a used, ¾ ton pickup truck for the department from Steve Schmitt Inc.

Discussion

The Parks and Recreation Department is in desperate need of a newer pickup truck. In addition, knowing the circumstances of the long delays of purchasing new vehicles over the past few years, we have an opportunity to purchase a gently used ¾ ton 4x4 pickup with 41,000 miles.

Currently, the dump truck used at the cemetery is in disrepair, and a second truck is unsafe to drive due to a large hole in the floorboard. We would sell these as surplus should the City Council agree to my request.

Fiscal Impact

The purchase price is \$40,192. I feel it is important to remind the City Council that we received a \$45,000 grant from T-Mobile for the recent playground installed at Silver Lake Park resulting in a savings.

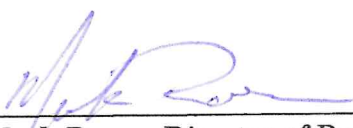

Recommended By: Mark Rosen, Director of Parks & Recreation

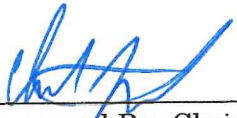

Approved By: Chris Conrad, City Manager

Steve Schmitt



GMC



www.steveschmittauto.com



STEVE SCHMITT INC.
12631 State Route 143
Highland, IL 62249
(618) 654-2181

STEVE SCHMITT OF LITCHFIELD
1 Galaxy Lane
Litchfield, IL 62056
(217) 324-3932

DATE 01/17/2024

PURCHASER'S NAME: **CITY OF HIGHLAND** PHONE #: **(618) 651-1386**
EMAIL: **bvazquez@highlandil.gov** S.S. #:
PURCHASER'S NAME:

ADDRESS: **1115 BROADWAY**
PO BOX 218
CITY: **HIGHLAND** STATE: **IL** ZIP: **62249-0218**

VEHICLE BEING PURCHASED

PLEASE ENTER MY ORDER FOR THE FOLLOWING: NEW CAR USED TRUCK STOCK NO. **P36943**

YEAR: **2021** MAKE: **CHEVROLET** TRUCK

MODEL OR SERIES: **SILVERADO 2500H** BODY TYPE: **4WD REG CAB 142**

COLOR: **WHITE** TRIM: **WORK TRUCK**

M.V.I. OR SERIAL NO.: **1GC3YLE74MF178462**

TO BE DELIVERED ON OR ABOUT: **01/17/2024** SALESMAN: **JEFFREY F CROAK**

I state that the odometer mileage on the vehicle being described above now reads miles/kilometers: **41011**

CHECK ONE BOX ONLY

- (1) I HEREBY CERTIFY THAT TO THE BEST OF MY KNOWLEDGE THE ODOMETER READING AS STATED ABOVE REFLECTS THE ACTUAL MILEAGE OF THE VEHICLE DESCRIBED BELOW.
- (2) I HEREBY CERTIFY THAT TO THE BEST OF MY KNOWLEDGE THE ODOMETER READING AS STATED ABOVE REFLECTS THE AMOUNT OF MILEAGE IN EXCESS OF DESIGNED MECHANICAL ODOMETER LIMIT OF 99,999 MILES/KILOMETERS OF THE VEHICLE DESCRIBED BELOW.
- (3) I HEREBY CERTIFY THAT TO THE BEST OF MY KNOWLEDGE THE ODOMETER READING AS STATED ABOVE IS NOT THE ACTUAL MILEAGE OF THE VEHICLE DESCRIBED BELOW AND SHOULD NOT BE RELIED UPON.

CHECK ONE BOX ONLY

- (1) I HEREBY CERTIFY THAT THE ODOMETER OF SAID VEHICLE WAS NOT ALTERED, SET BACK OR DISCONNECTED WHILE IN MY POSSESSION, AND I HAVE NO KNOWLEDGE OF ANYONE ELSE DOING SO.
- (2) I HEREBY CERTIFY THAT THE ODOMETER WAS ALTERED FOR REPAIR OR REPLACEMENT PURPOSES WHILE IN MY POSSESSION, AND THAT THE MILEAGE REGISTERED ON THE REPAIRED OR REPLACEMENT ODOMETER WAS IDENTICAL TO THAT BEFORE SUCH SERVICE.
- (3) I HEREBY CERTIFY THAT THE REPAIRED OR REPLACEMENT ODOMETER WAS INCAPABLE OF REGISTERING THE SAME MILEAGE, THAT IT WAS RESET TO ZERO, AND THAT THE MILEAGE ON THE ORIGINAL ODOMETER OR THE ODOMETER BEFORE REPAIR WAS

MILES/KILOMETERS: **41011** DATE: **01/17/2024**

USED VEHICLE TRADED-IN AND/OR OTHER CREDITS

YEAR: MAKE: MODEL OR SERIES: BODY TYPE: COLOR: TRIM: CODE: M.V.I. OR SERIAL NO. BALANCE OWED TO: ADDRESS:

I state that the odometer reading on the used vehicle traded-in described above was miles/kilometers at the time of transfer.

CHECK ONE BOX ONLY

- (1) I HEREBY CERTIFY THAT TO THE BEST OF MY KNOWLEDGE THE ODOMETER READING AS STATED ABOVE REFLECTS THE ACTUAL MILEAGE OF THE VEHICLE DESCRIBED BELOW.
- (2) I HEREBY CERTIFY THAT TO THE BEST OF MY KNOWLEDGE THE ODOMETER READING AS STATED ABOVE REFLECTS THE AMOUNT OF MILEAGE IN EXCESS OF DESIGNED MECHANICAL ODOMETER LIMIT OF 99,999 MILES/KILOMETERS OF THE VEHICLE DESCRIBED BELOW.
- (3) I HEREBY CERTIFY THAT TO THE BEST OF MY KNOWLEDGE THE ODOMETER READING AS STATED ABOVE IS NOT THE ACTUAL MILEAGE OF THE VEHICLE DESCRIBED BELOW AND SHOULD NOT BE RELIED UPON.

CHECK ONE BOX ONLY

- (1) I HEREBY CERTIFY THAT THE ODOMETER OF SAID VEHICLE WAS NOT ALTERED, SET BACK OR DISCONNECTED WHILE IN MY POSSESSION, AND I HAVE NO KNOWLEDGE OF ANYONE ELSE DOING SO.
- (2) I HEREBY CERTIFY THAT THE ODOMETER WAS ALTERED FOR REPAIR OR REPLACEMENT PURPOSES WHILE IN MY POSSESSION, AND THAT THE MILEAGE REGISTERED ON THE REPAIRED OR REPLACEMENT ODOMETER WAS IDENTICAL TO THAT BEFORE SUCH SERVICE.
- (3) I HEREBY CERTIFY THAT THE REPAIRED OR REPLACEMENT ODOMETER WAS INCAPABLE OF REGISTERING THE SAME MILEAGE, THAT IT WAS RESET TO ZERO, AND THAT THE MILEAGE ON THE ORIGINAL ODOMETER OR THE ODOMETER BEFORE REPAIR WAS

MILES/KILOMETERS: DATE:

Federal regulations require the odometer mileage to be stated upon transfer of ownership. An inaccurate statement may make the transferor liable for damages to the transferee, pursuant to section 409(a) of the Motor Vehicle Information and Cost Savings Act of 1972, Public Law 92-513.

CASH DELIVERED PRICE OF VEHICLE	\$ 39483.00
1. TOTAL VEHICLE PRICE	39483.00
TRADE IN ALLOWANCE OR DISCOUNT	N/A
3. TOTAL DIFFERENCE (1 - 2)	39483.00
4. LICENSE TRANSFER TITLE DOC FEE	150.00 N/A 165.00 358.00 674.00
6. OPTIONAL ERT FEE	35.00
7. TOTAL DIFFERENCE INCL TAX	40192.00
8. BALANCE OWED ON TRADE IN	N/A
9. OTHER CHARGES EXTENDED WARRANTY	N/A
10. UNPAID BALANCE	40192.00
11. CASH DOWN PAYMENT	DEPOSIT ON ORDER: N/A CASH ON DELIVERY: N/A TOTAL CASH DOWN: N/A
12. UNPAID BALANCE OF CASH PRICE	40192.00

HIGHWAY
 150.00
 N/A 165.00 358.00 674.00

Purchaser agrees that this Order includes all of the terms and conditions on both the face and reverse side hereof, that this Order cancels and supersedes any prior agreement and as of the date hereof comprises the complete and exclusive statement of the terms of the agreement relating to the subject matters covered hereby, and that THIS ORDER SHALL NOT BECOME BINDING UNTIL ACCEPTED BY DEALER OR HIS AUTHORIZED REPRESENTATIVE. Purchaser by his execution of this Order certifies he is of majority age and acknowledges that he has read its terms and conditions and has received a true copy of this order.

DISCLAIMER OF WARRANTIES

The Seller, STEVE SCHMITT AUTO GROUP, herein expressly disclaims all warranties, either express or implied, including any implied warranty of merchantability or fitness for a particular purpose, and neither assumes nor authorizes any other person to assume for it any liability in connection with the sale. Signing this retail order authorizes STEVE SCHMITT AUTO GROUP to do a credit check.

PURCHASER'S SIGNATURE: _____
PER: _____ (NAME AND TITLE) DATE: **01/17/24**

RESOLUTION NO. _____

**RESOLUTION AUTHORIZING THE SOLE SOURCE PURCHASE OF A USED
2021 CHEVY ¾ TON TRUCK FROM
STEVE SCHMITT, INC. FOR \$40,192.00, AND
WAIVING CUSTOMARY BIDDING PROCEDURES**

WHEREAS, the City of Highland, Madison County, Illinois (hereinafter "City"), is a non-home rule municipality duly established, existing and operating in accordance with the provisions of the Illinois Municipal Code (Section 5/1-1-1 *et seq.* of Chapter 65 of the Illinois Compiled Statutes); and

WHEREAS, the Director of Parks and Recreation has represented to the City Council that the Parks and Recreation Department is in dire need of a new truck; and

WHEREAS, the Director of Parks and Recreation has represented to the City Council that the dump truck at the cemetery is in disrepair and another truck used is not safe due to a hole in the floorboard; and

WHEREAS, the Director of Parks and Recreation has represented to the City Council that a used 2021 Chevy ¾ Ton truck with approximately 41,000 miles on the odometer has been located and would be sufficient for the Parks and Recreation Department's needs; and

WHEREAS, Steve Schmitt, Inc. has provided a proposed agreement (*See Exhibit A*; hereinafter "Steve Schmitt Agreement") for City's consideration; and

WHEREAS, the Steve Schmitt Agreement will allow City to purchase a used Chevy ¾ Ton Truck with 41,000 miles for \$40,192.00 (*See Exhibit A*); and

WHEREAS, City has determined it would be in the best interests of public health, safety, general welfare, and economic welfare to enter the Steve Schmitt Agreement (*See Exhibit A*); and

WHEREAS, City has determined this purchase is a sole source purchase because the Steve Schmitt Agreement allows City to purchase a used truck (*See Exhibit A*); and

WHEREAS, City has determined it to be appropriate to waive the customary bidding procedures and purchase the used Chevy ¾ Ton Truck from Steve Schmitt as a sole source purchase, and according to the Steve Schmitt Agreement (*See Exhibit A*); and

WHEREAS, City authorizes and directs the City Manager and/or Mayor to execute any documents necessary to waive customary bidding procedures and enter the Steve Schmitt Agreement (*See Exhibit A*).

NOW, THEREFORE, BE IT RESOLVED, by the Mayor and City Council of the City of Highland, Illinois, as follows:

Section 1. The foregoing recitals are incorporated herein as findings of the City Council of the City of Highland, Illinois.

Section 2. The Steve Schmitt Agreement (*See Exhibit A*) is approved.

Section 3. The City Manager and/or Mayor is directed and authorized, on behalf of the City of Highland, to execute any documents necessary to enter the Steve Schmitt Agreement (*See Exhibit A*).

Section 4. This Resolution shall be known as Resolution No. _____, and shall be effective upon its passage and approval in accordance with Illinois law.

Passed by the City Council of the City of Highland, Illinois, and deposited and filed in the Office of the City Clerk, on the ____ day of _____, 2024, the vote being taken by ayes and noes, and entered upon the legislative records, as follows:

AYES:

NOES:

ABSENT:

APPROVED:

Kevin B. Hemann
Mayor
City of Highland
Madison County, Illinois

ATTEST:

Barbara Bellm
City Clerk
City of Highland
Madison County, Illinois



STEVE SCHMITT INC. **STEVE SCHMITT OF LITCHFIELD**
 12631 State Route 143 1 Galaxy Lane
 Highland, IL 62249 Litchfield, IL 62056
 (618) 654-2181 (217) 324-3932

DATE **01/17/2024**

PURCHASER'S NAME PHONE #
CITY OF HIGHLAND **(618) 651-1386**

EMAIL S.S. #
bvazquez@highlandil.gov

PURCHASER'S NAME
 EMAIL S.S. #

ADDRESS **1115 BROADWAY**
PO BOX 218
 CITY STATE ZIP
HIGHLAND **IL** **62249-0218**

VEHICLE BEING PURCHASED

PLEASE ENTER MY ORDER NEW CAR STOCK NO.
 FOR THE FOLLOWING USED TRUCK **P36943**

YEAR **2021** MAKE **CHEVROLET TRUCK**

MODEL OR BODY
 SERIES TYPE
SILVERADO 2500H **4WD REG CAB 142**

COLOR **WHITE** TRIM **WORK TRUCK**

M.V.I. OR
 SERIAL NO. **1GC3YLE74MF178462**

TO BE DELIVERED
 ON OR ABOUT **01/17/2024** SALESMAN **JEFFREY F. CROAK**

I state that the odometer mileage on the vehicle
 being described above now reads miles/kilometers. **41011**

CHECK ONE BOX ONLY

- (1) I HEREBY CERTIFY THAT TO THE BEST OF MY KNOWLEDGE THE ODOMETER READING AS STATED ABOVE REFLECTS THE ACTUAL MILEAGE OF THE VEHICLE DESCRIBED BELOW.
- (2) I HEREBY CERTIFY THAT TO THE BEST OF MY KNOWLEDGE THE ODOMETER READING AS STATED ABOVE REFLECTS THE AMOUNT OF MILEAGE IN EXCESS OF DESIGNED MECHANICAL ODOMETER LIMIT OF 99,999 MILES/KILOMETERS OF THE VEHICLE DESCRIBED BELOW.
- (3) I HEREBY CERTIFY THAT TO THE BEST OF MY KNOWLEDGE THE ODOMETER READING AS STATED ABOVE IS NOT THE ACTUAL MILEAGE OF THE VEHICLE DESCRIBED BELOW AND SHOULD NOT BE RELIED UPON.

CHECK ONE BOX ONLY

- (1) I HEREBY CERTIFY THAT THE ODOMETER OF SAID VEHICLE WAS NOT ALTERED, SET BACK OR DISCONNECTED WHILE IN MY POSSESSION, AND I HAVE NO KNOWLEDGE OF ANYONE ELSE DOING SO.
- (2) I HEREBY CERTIFY THAT THE ODOMETER WAS ALTERED FOR REPAIR OR REPLACEMENT PURPOSES WHILE IN MY POSSESSION, AND THAT THE MILEAGE REGISTERED ON THE REPAIRED OR REPLACEMENT ODOMETER WAS IDENTICAL TO THAT BEFORE SUCH SERVICE.
- (3) I HEREBY CERTIFY THAT THE REPAIRED OR REPLACEMENT ODOMETER WAS INCAPABLE OF REGISTERING THE SAME MILEAGE, THAT IT WAS RESET TO ZERO, AND THAT THE MILEAGE ON THE ORIGINAL ODOMETER OR THE ODOMETER BEFORE REPAIR WAS

MILES/KILOMETERS.
 X _____ DATE **01/17/2024**

USED VEHICLE TRADED-IN AND/OR OTHER CREDITS

YEAR MAKE STOCK NO.

MODEL OR BODY
 SERIES TYPE

COLOR TRIM CODE #

M.V.I. OR
 SERIAL NO.

BALANCE
 OWED TO

ADDRESS

I state that the odometer reading on the used vehicle traded-in
 described above was miles/kilometers at the time of transfer.

CHECK ONE BOX ONLY

- (1) I HEREBY CERTIFY THAT TO THE BEST OF MY KNOWLEDGE THE ODOMETER READING AS STATED ABOVE REFLECTS THE ACTUAL MILEAGE OF THE VEHICLE DESCRIBED BELOW.
- (2) I HEREBY CERTIFY THAT TO THE BEST OF MY KNOWLEDGE THE ODOMETER READING AS STATED ABOVE REFLECTS THE AMOUNT OF MILEAGE IN EXCESS OF DESIGNED MECHANICAL ODOMETER LIMIT OF 99,999 MILES/KILOMETERS OF THE VEHICLE DESCRIBED BELOW.
- (3) I HEREBY CERTIFY THAT TO THE BEST OF MY KNOWLEDGE THE ODOMETER READING AS STATED ABOVE IS NOT THE ACTUAL MILEAGE OF THE VEHICLE DESCRIBED BELOW AND SHOULD NOT BE RELIED UPON.

CHECK ONE BOX ONLY

- (1) I HEREBY CERTIFY THAT THE ODOMETER OF SAID VEHICLE WAS NOT ALTERED, SET BACK OR DISCONNECTED WHILE IN MY POSSESSION, AND I HAVE NO KNOWLEDGE OF ANYONE ELSE DOING SO.
- (2) I HEREBY CERTIFY THAT THE ODOMETER WAS ALTERED FOR REPAIR OR REPLACEMENT PURPOSES WHILE IN MY POSSESSION, AND THAT THE MILEAGE REGISTERED ON THE REPAIRED OR REPLACEMENT ODOMETER WAS IDENTICAL TO THAT BEFORE SUCH SERVICE.
- (3) I HEREBY CERTIFY THAT THE REPAIRED OR REPLACEMENT ODOMETER WAS INCAPABLE OF REGISTERING THE SAME MILEAGE, THAT IT WAS RESET TO ZERO, AND THAT THE MILEAGE ON THE ORIGINAL ODOMETER OR THE ODOMETER BEFORE REPAIR WAS

MILES/KILOMETERS.
 X _____ DATE _____

Federal regulations require the odometer mileage to be stated upon transfer of ownership. An inaccurate statement may make the transferor liable for damages to the transferee, pursuant to section 409(a) of the Motor Vehicle Information and Cost Savings Act of 1972, Public Law 92-513.

CASH DELIVERED PRICE OF VEHICLE	\$	39483	00
1. TOTAL VEHICLE PRICE		39483	00
2. TRADE IN ALLOWANCE OR DISCOUNT		N/A	
3. TOTAL DIFFERENCE (1 - 2)		39483	00
4. TAX		N/A	
LICENSE	TRANSFER	TITLE	DOC FEE
151.00	N/A	165.00	358.00
6. OPTIONAL ERT FEE		35	00
7. TOTAL DIFFERENCE INCL. TAX		40192	00
8. BALANCE OWED ON TRADE IN		N/A	
9. OTHER CHARGES	EXTENDED WARRANTY		N/A
10. UNPAID BALANCE		40192	00
11. CASH DOWN PAYMENT	DEPOSIT ON ORDER	N/A	
	CASH ON DELIVERY	N/A	
TOTAL CASH DOWN			N/A
12. UNPAID BALANCE OF CASH PRICE		40192	00

Purchaser agrees that this Order includes all of the terms and conditions on both the face and reverse side hereof, that this Order cancels and supersedes any prior agreement and as of the date hereof comprises the complete and exclusive statement of the terms of the agreement relating to the subject matters covered hereby, and that THIS ORDER SHALL NOT BECOME BINDING UNTIL ACCEPTED BY DEALER OR HIS AUTHORIZED REPRESENTATIVE. Purchaser by his execution of this Order certifies he is of majority age and acknowledges that he has read its terms and conditions and has received a true copy of this order.

DISCLAIMER OF WARRANTIES

The Seller, STEVE SCHMITT AUTO GROUP, herein expressly disclaims all warranties, either express or implied, including any implied warranty of merchantability or fitness for a particular purpose, and neither assumes nor authorizes any other person to assume for it any liability in connection with the sale. Signing this retail order authorizes STEVE SCHMITT AUTO GROUP to do a credit check.

PURCHASER'S SIGNATURE

PER _____ DATE **01/17/24**
 (NAME AND TITLE)



HIGHLAND

PARKS & RECREATION... The *FUN* Theory!

To: Chris Conrad, City Manager

From: Mark Rosen, Director of Parks & Recreation
Brad Koehnemann, Parks & Athletics Mgr.
Ryan Hummert, Natural Resources Mgr.

Date: February 5, 2024

Subject: Outdoor Pool Fee Increase

Recommendation

I am recommending city council approval for a sole source quote to purchase a used, ¾ ton pickup truck for the department from Steve Schmitt Inc.

Discussion

The Parks and Recreation Department is in desperate need of a newer pickup truck. In addition, knowing the circumstances of the long delays of purchasing new vehicles over the past few years, we have an opportunity to purchase a gently used ¾ ton 4x4 pickup with 41,000 miles.

Currently, the dump truck used at the cemetery is in disrepair, and a second truck is unsafe to drive due to a large hole in the floorboard. We would sell these as surplus should the City Council agree to my request.

Fiscal Impact

The purchase price is \$40,192. I feel it is important to remind the City Council that we received a \$45,000 grant from T-Mobile for the recent playground installed at Silver Lake Park resulting in a savings.

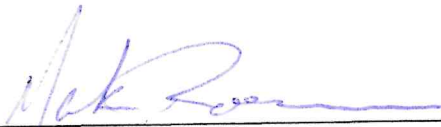

Recommended By: Mark Rosen, Director of Parks & Recreation

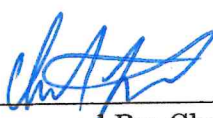

Approved By: Chris Conrad, City Manager

Highland Community Pool 2024 Proposed Rates

Current Proposed

DAILY RATES

Youth (3-17)	\$3.00	\$4.00
Adult (18-59)	\$4.00	\$5.00
Senior (60+)	\$2.00	\$3.00

SEASON PASS

Resident

Youth	\$55	\$60
Adult	\$75	\$80
Senior	\$37.50	\$45
Family of 5	\$105	\$120
Add'l Family Members	\$10	\$10

Non-resident

Youth	\$80	\$85
Adult	\$95	\$100
Senior	\$47.50	\$55
Family of 5	\$140	\$155
Add'l Family Members	\$10	\$10

ORDINANCE NO. _____

**ORDINANCE AMENDING CITY CODE, CHAPTER 46 – PARKS AND RECREATION,
ARTICLE IV – SWIMMING POOL, SECTION 46-51, INCREASING SELECT RATES
FOR DAY AND SEASON PASSES**

WHEREAS, the City of Highland, Madison County, Illinois (hereinafter “City”), is a non-home rule municipality duly established, existing and operating in accordance with the provisions of the Illinois Municipal Code (Section 5/1-1-1 et seq. of Chapter 65 of the Illinois Compiled Statutes); and

WHEREAS, City has determined it necessary to amend the City Code and increase the rates for use of the City Outdoor Pool as follows:

	<u>Current</u>	<u>Proposed</u>
DAILY RATES		
Youth (3-17)	\$3.00	\$4.00
Adult (18-59)	\$4.00	\$5.00
Senior (60+)	\$2.00	\$3.00
SEASON PASS		
Resident		
Youth	\$55	\$60
Adult	\$75	\$80
Senior	\$37.50	\$45
Family of 5	\$105	\$120
Add’l Family Members	\$10	\$10
Non-resident		
Youth	\$80	\$85
Adult	\$95	\$100
Senior	\$47.50	\$55
Family of 5	\$140	\$155
Add’l Family Members	\$10	\$10

and

WHEREAS, the City Council finds that the City Manager and/or Mayor should be authorized and directed, on behalf of the City, to execute whatever documents are necessary to amend the City Code to reflect the changes in rates charged for the City Outdoor Pool as stated herein.

NOW, THEREFORE, BE IT ORDAINED, by the City Council of the City of Highland, Illinois, as follows:

Section 1. The foregoing recitals are incorporated herein as findings of the City Council of the City of Highland, Illinois.

Section 2. Chapter 46 – Parks and Recreation, Article IV – Swimming Pool, Section 46-51 – Outdoor Swimming Pool, shall be amended as follows:

Sec. 46-51. - Outdoor swimming pool.

(a)Purpose. To promote health, safety, general welfare, and economic welfare, the City of Highland ("City") shall set the following rate schedule for use of the City outdoor swimming pool:

(b)Definitions.

(1)Resident - any individual living within the corporate limits of City.

(2)Non-Resident -any individual living outside the corporate limits of City.

(c)Daily Admission for City outdoor swimming pool.

(1)Youth (ages 3-17)

a.Resident \$4.00

b.Non-Resident \$5.00

(2)18 years of age up to 59 years of age

a.Resident \$5.00

b.Non-Resident \$6.00

(3)60 years of age or more

a.Resident \$3.00

b.Non-Resident \$4.00

(4)Group Rate - during regular pool hours only, and not applicable to any other rates stated herein, groups of 20 or more individuals will receive a \$.50 discount off the daily admission rate and the right to re-entry all day. Group rate applicants must present at the same time to receive the Group Rate discount.

(d)Season Pass for City outdoor swimming pool.

(1)Youth (ages 3-17)

a.Resident \$60.00

b.Non-Resident \$85.00

(2)18 years of age up to 59 years of age

a.Resident \$80.00

b.Non-Resident \$100.00

(3)60 years of age or more

- a.Resident \$45.00
- b.Non-Resident \$55.00

(4)Family (up to five family members)

- a.Resident \$120.00
- b.Non-Resident \$155.00

(5)Family (each additional family member after five family members)

- a.Resident \$10.00
- b.Non-Resident \$10.00

(6)Korte Recreation Center members who have a valid annual membership through Labor Day receive a 20 percent discount on season passes

Section 3. That this Ordinance shall be known as Ordinance No. _____ and shall be effective upon adoption with implementation date of March 1, 2024.

This Ordinance adopted by the City Council of the City of Highland, Illinois and deposited and filed in the office of the City Clerk on the _____ day of _____, 2024, the vote taken by ayes and nays and entered upon the legislative records as follows:

AYES:

NAYS:

ABSENT:

APPROVED:

Kevin B. Hemann, Mayor
City of Highland,
Madison County, Illinois

ATTEST:

Barbara Bellm, City Clerk
City of Highland,
Madison County, Illinois



HIGHLAND

PARKS & RECREATION... The *FUN* Theory!

To: City Manager, Chris Conrad
From: Mark Rosen, Director of Parks & Recreation
Date: February 5, 2024
Subject: Madison County PEP Grant

Recommendation

I am recommending city council to approve a resolution for the Madison County PEP Grant. This is an annual per-capita grant.

Discussion

This grant will provide \$54,940.00 to go toward the purchase of new playground at Silver Lake Park and Glik Park. In addition, we intend to replace hanging baskets that are placed on light poles around the Square.

Fiscal Impact

Total Project Costs:	\$55,025.73
County Funding Requested:	<u>\$54,940.00</u>
Impact to P & R Budget:	\$85.73

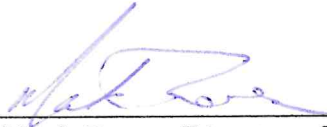

Recommended By: Mark Rosen, Director of Parks & Recreation

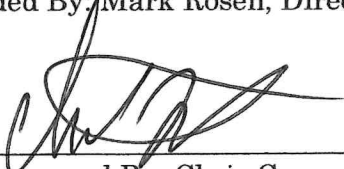

Approved By: Chris Conrad, City Manager

RESOLUTION NO. _____

**RESOLUTION AUTHORIZING THE MAYOR AND/OR CITY MANAGER
TO APPLY FOR PARK COMMISSION FUNDS
FROM MADISON COUNTY, ILLINOIS**

WHEREAS, the City of Highland, Madison County, Illinois (hereinafter “City”), is a non-home rule municipality duly established, existing and operating in accordance with the provisions of the Illinois Municipal Code (Section 5/1-1-1 et seq. of Chapter 65 of the Illinois Compiled Statutes); and

WHEREAS, the City of Highland, Illinois, proposes to apply for Park Enhancement Funding (“PEP”) funds for the following project(s):

1. Playground Equipment;
2. Hanging Baskets

(See **Exhibit A**); and

WHEREAS, the funding for the projects may exceed the actual amount granted from PEP funds in which the City of Highland, Illinois, agrees to fund the completion of the project from another source; and

NOW, THEREFORE, BE IT RESOLVED that the City Council of the City of Highland, Illinois, authorizes the filing of the above-listed applications to Madison County in adherence to all applicable rules and regulations of the PEP program; and

BE IT FURTHER RESOLVED that the City Council of the City of Highland, Illinois, hereby directs and designates the Mayor and/or City Manager to act as the authorized representative in connection with the filing of the aforementioned applications and all concurrent meetings and hearings associated with the project approval process.

Passed by the City Council of the City of Highland, Illinois, and deposited and filed in the Office of the City Clerk, on the _____ day of _____, 2024, the vote being taken by ayes and noes, and entered upon the legislative records, as follows:

AYES:

NOES:

ABSENT:

APPROVED:

Kevin B. Hemann, Mayor, City of Highland,
Madison County, Illinois

ATTEST:

Barbara Bellm
City Clerk
City of Highland
Madison County, Illinois



**INSTRUCTIONS FOR SUBMITTAL OF
FY 2024 PARK AND RECREATION PEP GRANTS**

This application contains the program guidelines, project application pages and park board resolution. When submitting the grant application return pages 7-11 along with bids or quotes. Please submit one unbound original signed grant application proposal.

The items included in this package are:

- Request for Proposal (RFP)
- Grant Agreement
- Applicant Information
- Proposed Budget & Scope of Project
- Grant Application Checklist
- Signed Resolution

Specific Instructions

1. Please submit **ONE** original, **UNBOUND** copy. Grant Applications should be stapled in the upper left hand corner.
2. Read and sign the Grant Agreement (page 7)
3. Complete and sign the Applicant Information Page (page 8-9)
4. Complete the Budget and Scope of Project Page (page 10). Please make sure to provide detailed locations of the project(s).
5. Include copies of bids or quotes for all proposed project activities. Applications that have no bids or quotes will not be funded.
6. Include copies of information pertaining to projects to be completed with grant funds, including but not limited to photos, equipment specifications.
7. Please indicate what provisions will be made for people with disabilities in compliance with the Americans with Disabilities Act and the Illinois Accessibility Code. All projects applications that include construction **MUST** include a sign-off from IMPACT, an engineer or architect. Applications missing the provisions for persons with disabilities will not be funded.
8. Resolution approving submission of the 2024 PEP Grant (Page 11). Applications that are missing the Resolution signed by their governing board will not be funded.
9. Purchases should follow your city or park district bid ordinances, in accordance to Illinois Park code, 70 ILSC 1205/ et. Seq. If the park district does not have bid process, Madison County procurement policy must be followed. Each purchase made by the park must have a minimum of three (3) bids if the park district does not have a formal procurement policy. Failure to provide bids, quotes or estimates with your grant application will result in your grant not being funded. Any construction/labor job that is bid out must use the State Prevailing Wage Rate. The community will be required to obtain and monitor time sheets from the contractor.
10. Required bid documents will be required with the submission of invoices or reimbursements.



2024

[MADISON COUNTY PARKS AND RECREATION COMMISSION]

***Applications must be submitted no later than by 4:00 P.M., on February 16, 2024, to the Madison County Community Development office, 157 N. Main, Suite 312, Edwardsville, IL 62025.** If you would like an electronic version of this application, please e-mail us. Please direct all questions to:

Holly Klausing
Madison County Community Development
157 N. Main St., Suite 312
Edwardsville, IL 62025
hmklausing@madisoncountyil.gov
(618) 296-4247

Application Check List

- ONE original, UNBOUND copy.** Grant applications should be stapled in the upper left hand corner.
 - Signed Grant agreement
 - Completed and signed Applicant Information
 - Completed Budget and Scope of Project Page
 - Copies quotes for all proposed funding. Required bid documents must be submitted with invoices.
 - Copies of information pertaining to projects to be completed with grant funds, including but not limited to photos, equipment specifications.
 - Provisions for people with disabilities.
 - Resolution approving submission of the 2024 PEP Grant.
-

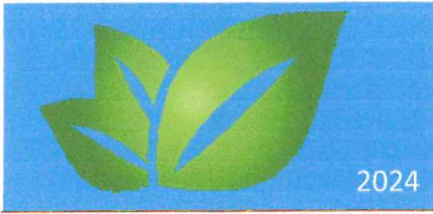

REQUEST FOR PROPOSALS

MADISON COUNTY PARK AND RECREATION GRANT COMMISSION PARK ENHANCEMENT PROGRAM

The Madison County Park and Recreation Grant Commission (hereafter Commission), is announcing a request for proposals for the 2024 PEP Grant Program. This grant program is designed to assist park districts and municipal parks and recreation departments within Madison County to develop and enhance their parks. The goal of the program is to provide immediate assistance to the park districts and departments. The Commission plans to have the grants in place following approval by the Madison County Board on **March 13, 2024**. This grant program is designed to supplement, not replace, or reduce levels of funding set in a community's budget for park operations.

ELIGIBLE APPLICANTS:

Eligible applicants are park districts, municipal park and recreation departments, and local units of government within Madison County, Illinois.

Eligible applicants are:

- Park districts, municipal park and recreation departments, local units of government within Madison County.
- The municipality must have a park commission, board or committee designated to oversee the park operations and maintenance.
- The municipality and/or park district must have a park and/or recreation area that is owned and operated by the municipality or park district.

GRANT COORDINATION:

In an effort to reduce administrative costs and with the permission of the Madison County Board and its Chairman, the Commission has been allowed to utilize the services of the Madison County Community Development (MCCD) offices and their staff to accept applications and coordinate processing.

GRANT DEADLINE

Completed applications are due at Madison County Community Development, 157 N. Main St., Suite 312, Edwardsville, IL 62025, **no later than 4:00pm on February 16, 2024.**

GRANT AWARD NOTIFICATION

Notification of grants to be awarded will be made after the **March 13, 2024**, Madison County Board Meeting.

OWNERSHIP REQUIREMENT

Land and equipment purchased with PEP funds must be owned and maintained by the park district and/or local unit of government applying for funding.

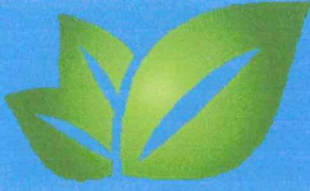

MAXIMUM GRANT AMOUNT

- For the 2024 PEP grant, the maximum grant amount shall be determined based upon the population of the municipality that has a park department or the park district generally serving the municipality.
- The maximum grant amount shall be \$5.50 per capita based upon the 2020 census.
- Special census' that were conducted prior to the 2020 census are no longer valid.
- Population figures shall not be duplicated in cases of city/township. Residents will only be counted in one population area.
- If there is a dispute between city/township/district, it is up to the city/township/district to accurately provide proof of population courtesy of tax bodies, addresses, etc.
- For our smaller communities a grant minimum of \$15,000 will be awarded if the \$5.50 per capita total is less than the \$15,000 amount.

ELIGIBLE EXPENDITURES

Madison County PEP grant funding must be used for projects that enhance the use of public parks that are open to the public. The Grants Committee, Parks and Recreation Advisory Committee and Madison County Community Development hold the right to determine final eligibility.

Eligible types of capital improvements include but are not limited to the following:

- Playground equipment
- Plants, shrubs, trees, flowers, etc.
- Fencing
- Recreation equipment – basketballs, softballs, bleachers, etc.
- Land acquisition to expand existing park
- Benches, fountains, picnic tables, grill, etc.
- Facility improvements such as athletic fields and courts
- Park restrooms that are ADA accessible/compliant
- Park walking paths
- Lake/pond improvements
- Gazebos
- Pet parks
- Greenhouses
- AED's
- First time construction of concession stand
- ADA parking for park lots
- Park signage*
- Major recreation facilities*
- Mowers

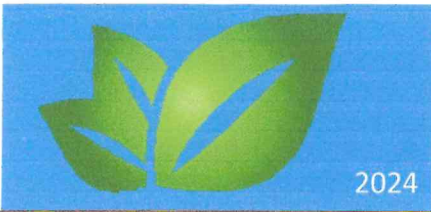

INELIGIBLE EXPENDITURES

The funds may not be used for administration purposes and operating costs. If there is a membership fee to your park or recreation complex, then equipment purchases for that park or recreation complex are ineligible unless approved.*

Ineligible types of grants are as follows:

- Architect or engineering design fees
- Staff salaries, benefits
- Transportation & mileage
- Maintenance supplies
- Digital cameras or other electronic office equipment such as LCD monitors, gaming systems and games and projection screens
- Weight or fitness equipment, unless there is free membership
- General office equipment/supplies
- Improvements made to staff or office spaces such as adding carpeting, adding a drop ceiling, air conditioning a break room
- Pop-up tents/tents
- Road/parking improvements*
- Maintenance sheds/other areas not open to the public*
- Other wheeled equipment*
- Concession stand equipment*

***Maintenance sheds, signage, other wheeled vehicles, concession stand equipment and major recreation facilities will be considered for PEP Grant funds on a case-by-case basis. Additional support documentation shall be submitted demonstrating the benefit of the project to the community's residents and to the park and recreation program the governmental entity provides. The Commission will accept written requests for these projects no later than February 16, 2024 by 4:00pm. A determination of the project selection will be made at the subsequent Park Commission meeting to be held on March 1, 2024 at 8:00am. If the project is not awarded, an alternative project may be submitted.**

MATCHING FUND REQUIREMENT

For the 2024 PEP, no matching funds are required. However, the PEP Grant may be used as match funding for other park grants.

EVALUATION

The Commission will evaluate all complete proposals received by the deadline. Additional information may be asked of the grantees.



PURCHASING REQUIREMENTS

Purchases should follow your city or park district bid ordinances, in accordance to Illinois Park code, 70 ILCS 1205/ et. Seq. If the park district does not have bid process, Madison County procurement policy must be followed. Each purchase made by the park must have a minimum of three (3) bids if the park district does not have a formal procurement policy. Failure to provide bids, quotes or estimates with your grant application will result in your grant not being funded. Any construction/labor job that is bid out must use the State Prevailing Wage Rate. The community will be required to obtain and monitor time sheets from the contractor.

REPORTING REQUIREMENTS

Within ninety (90) days of completion of project, the grantee must send a report to Grant Commission via MCCC. This report should document all activities pertaining to the original grant request, e.g. photos of the equipment purchased, photos of equipment in use or on location such as playground equipment.

PUBLIC RELATIONS

Madison County Community Development will coordinate public relations support on the respective projects funded by the park and recreation PEP Grants. Based on the scope of the grant and project, the support will include news and photo releases. Additional information on the public relations support can be obtained by contact Holly Klausung at (618) 296-4247 or hmklusung@madisoncountyl.gov.

PAYMENT SCHEDULE

Payments will not be processed without completed W9's

PEP Grant funding can be paid out using either of the following options at the discretion of the park district or municipality.

- **Payment Option 1:** Funds may be distributed directly to the vendors. To accomplish this, the community/park district should submit to MCCC, the original invoice accompanied by a cover letter from the community requesting the direct vendor payment and W-9 for the vendor. All bid documentation as well as a copy of the letter of award to that vendor, must be on file at MCCC before payment will be made. Bid documentation must be turned in with each invoice request or the invoice will not pay the bill. ***Past due invoices will only be paid on a reimbursement basis***
- **Payment Option 2:** The entire grant amount can be reimbursed to the community after the project is completed. In order for a payment to be released, we will need a letter from the community requesting reimbursement, as well as a copy of all invoices and receipts, and all cancelled checks for the item(s) purchased. All bid documentation as well as a copy of the letter of award to that vendor, must be on file at MCCC before reimbursement will be made.

MODIFICATION OF REQUESTS FOR PROPOSALS

It is the intent of the Commission to provide these grants according to the terms above but shall not be bound by this procedure for future grant awards. Any conflicts and all final decisions will be determined by majority vote of the Park and Recreation Grants Commission.

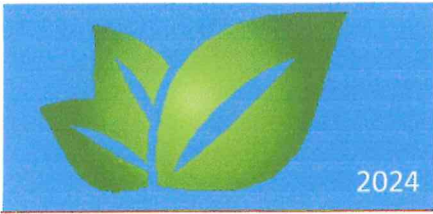

MADISON COUNTY PARK AND RECREATION GRANTS COMMISSION PARK ENHANCEMENT PROGRAM (PEP) GRANT AGREEMENT & CERTIFICATIONS

- 1. The grant amount cannot exceed the maximum grant allowed to the entity as outlined in the Request for Proposals. The grant award shall be for the specified project only. Salaries, mileage, transportation costs, shall not be paid with grant funds.
2. Upon acceptance of the application by the Commission Board, and the Grants Committee, and Madison County Board, the grantee agrees to submit invoices or receipts for the project to MCCD, along with a request for payment.
3. The grantee agrees to include the source of funding in press releases, articles, or public dedication ceremonies regarding the project or programs utilizing PEP funding. The grantee is responsible for contacting their current Madison County Board Member to coordinate a press release, etc., that relates to the project or programs using PEP funding.
4. The grantee agrees to use the PEP funds outlined in this application no later than April 1, 2025.
5. No equipment or materials purchased with PEP funds will be used for purposes other than those stated in this application.
6. All Purchases must be made in accordance with grantee's local bid ordinances, bid policies, state statutes or by the provisions contained in these grant documents.
7. There shall be no transfer of ownership of any equipment/land purchased with these funds without notification and approval by the Madison County Park and Recreation Grants Commission.

I have read the above certifications and agree to honor them as written. I certify with my signature that the information contained in this application is accurate to the best of my knowledge and that I am authorized to execute this application for my community.

Mark Rosen
Name/Title

Signature

Highland Parks & Rec
Name of Park District

February 9, 2024
Date

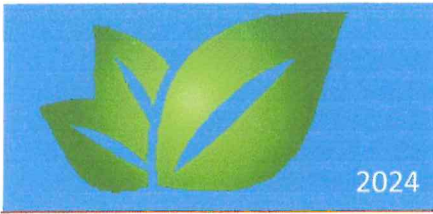

**APPLICANT INFORMATION FOR THE 2024
MADISON COUNTY PARK &
RECREATION GRANT COMMISSION
PARK ENHANCEMENT PROGRAM (PEP)**

February 9, 2024
Date

Highland Parks & Recreation
Name of District

P.O. Box 218 Highland 62249
Address City Zip

Mark Rosen Dir. Parks & Rec 651-8899 mdrosen@highlandil.gov
Contact Person Title Phone # E-mail Address

P.O. Box Highland 62249
Address City Zip

Please certify with your signature that the information contained in this application is accurate to the best of your knowledge and that you are authorized to execute this application for your community.

Signature

Please enter totals from attached proposal budget

A. Total Project Costs: \$55,025.73

B. County Funding Requested: \$54,940.00

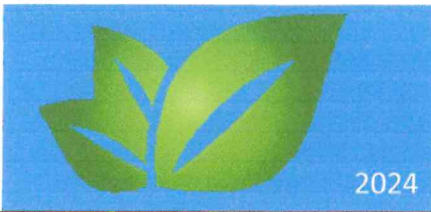

**PROVISIONS FOR PEOPLE WITH DISABILITIES
Required for all Projects**

Please indicate what provisions will be made for people with disabilities in compliance with the Americans with Disabilities Act and the Illinois Accessibility Code. All projects **MUST** include a sign-off from IMPACT, CIL, a certified engineer or certified architect. The sign-off is a recommendation or certification on how to bring the project(s) into ADA compliance. It is expected that each community/park district incorporate these recommendations into their application.

It is also permissible to choose pre-fab products (picnic tables, bleachers) that are certified by a reputable company as ADA accessible. However, it is still the municipality/park districts responsibility to insure that pathways leading up to the modified/improved areas are ADA compliant/accessible as well.

Also, please note that some purchases, like drinking fountains, would require an accessible drinking fountain option. Information about accessible equipment can also be obtained from IMPACT, CIL.

The City of Highland's purchases will be from playground companies that meet and/or exceed ADA accessible requirements. In the situations where access is limited however, the department staff will install accessible ramps, sidewalks, etc. for guests with special needs to access the play features.



PROPOSED BUDGET & SCOPE OF PROJECT

Name of Community

TOTAL ESTIMATED COSTS

\$55,025.73

PARK COMMISSION
FUNDING REQUESTED

\$54,940.00

Scope of Project: (Include the name and address of the park(s))

* Glik Park – 12525 Sportsman Road: A Gravity Cube will be installed to replace a 30-year old rail-rider that has become a maintenance issue as well as having obsolete parts to make repairs.

* Silver Lake Park – 3035 Highland Park Road: Two (2) new play features will be installed near pavilions.

The first item for Pavilion #4 will be a dual swing set. The second item will be at Pavilion #5 and is a climbing net apparatus. (please refer to photos attached)

* Downtown Square – 914 Main Street: Purchase six (6) hanging flower baskets that are exact matches for baskets that are in need of being replaced.

The application must be submitted no later than 4:00 P.M., on February 16, 2024, to the Madison County Community Development.

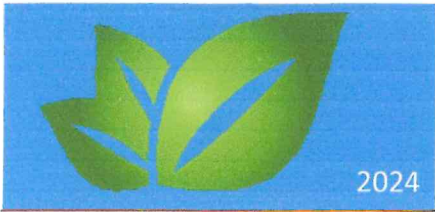

RESOLUTION

Resolution authorizing the Mayor/Supervisor/Park Board
To Apply for Park Commission Funds
From Madison County

WHEREAS, the _____ (village, city, township or park board) proposes to apply for PEP funds for the following project(s):

_____ ; and

WHEREAS, the funding for the projects may exceed the actual amount granted from PEP funds in which the village, city, township or park board of _____ agrees to fund the completion of the project from another source;

NOW, THEREFORE, BE IT RESOLVED that the official board of the village, city, township or park board of _____ authorizes the filing of the above listed applications to Madison County in adherence to all applicable rules and regulations of the PEP program; and

BE IT FURTHER RESOLVED that the official board of the village, city, township or park board of _____ hereby directs and designates the chief elected official to act as the authorized representative in connection with the filing of the aforementioned applications and all concurrent meetings and hearings associated with the project approval process.

PASSED this _____ day of _____, 2024.

Signature of elected official

Attested by Clerk/Secretary



HUTCHINSON RECREATION & DESIGN
 1000 EDGEWATER PT STE 101
 LAKE SAINT LOUIS, MO 63367

BID A

Name/Address		
Highland Parks Mark Rosen #1 Nagel Drive Highland, IL. 62249		
Date	Quotation #	REP
12/13/23	13118	BJH

Terms
See Attached

Quantity	Description	Total
1	Miracle Gravity Cube	21,574.00T
1	Freight - UNLOADING/STORAGE OF EQUIPMENT IS NOT INCLUDED IN DELIVERED PRICE.	
	Additional Add On Options (Included in Total):	
1	Equipment Installation Only (For Additional Installation options not listed on quote please view Proposal Facts). Please note items by other: Storage of Equipment, Site work, Site Excavation, Site Restoration, Drainage, Safety Surfacing, Safety Surfacing Install, etc. If you would like pricing on any of these additional items please let us know.	
1	Unload Equipment On-Site For Storage / Security By Other.	
	PLEASE NOTE: REMOVAL OF EXISTING EQUIPMENT AND FOOTINGS BY OTHER PUSHING BACK EXISTING SAFETY SURFACING TO DIRT BASE AND RE-INSTALL BY OTHER FILLING OF FOOTING HOLES FROM EQUIPMENT REMOVAL BY OTHER Tax Exempt	0.00

The acceptance signature below serves as authorization to order the items quoted & indicates acceptance of the listed prices and terms enclosed. Signature will not substitute for a Purchase Order.

Total \$21,574.00

Unloading, storage and installation of equipment upon arrival is not included in above pricing unless specifically noted on quote.

Acceptance Signature: _____

Printed Name: _____

Phone: (800) 848.5616

www.hutchinson-recreation.com

Fax: (314) 332.2877

NOTE: Purchase orders & checks for equipment should be made out to Hutchinson Recreation & Design.

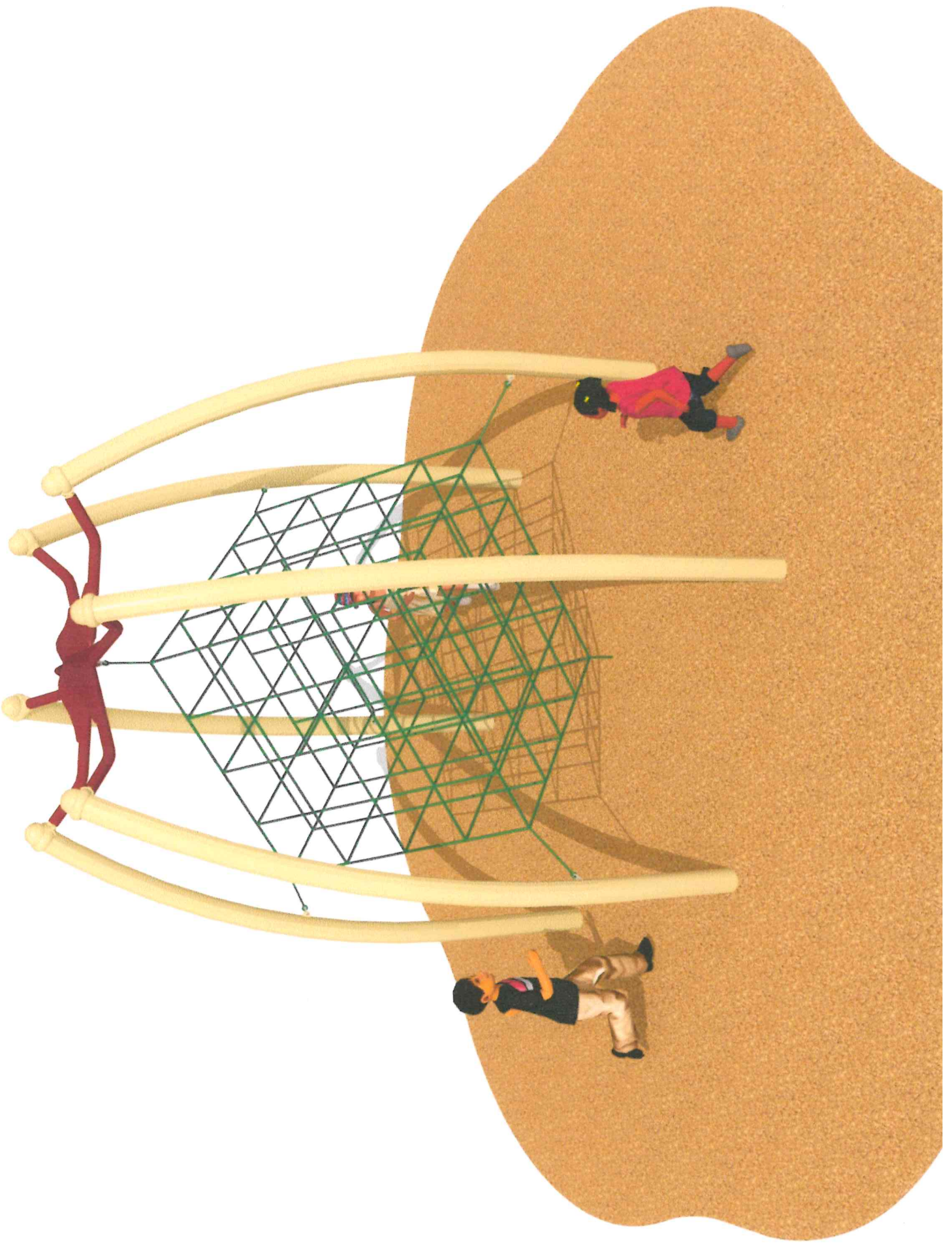

Glik Park - Opt A
Highland, IL

AGE GROUP: 5-12
USE GROUP: 1-1
BASE GROUND PLAY ACTIVITIES: TOTAL: 0
ELEVATED PLAY ACTIVITIES ACCESSIBLE BY TRANSFER: 0
ELEVATED PLAY ACTIVITIES ACCESSIBLE BY RAMP: 0
GROUND LEVEL ACTIVITY TYPE: 1
GROUND LEVEL QUANTITY: 1

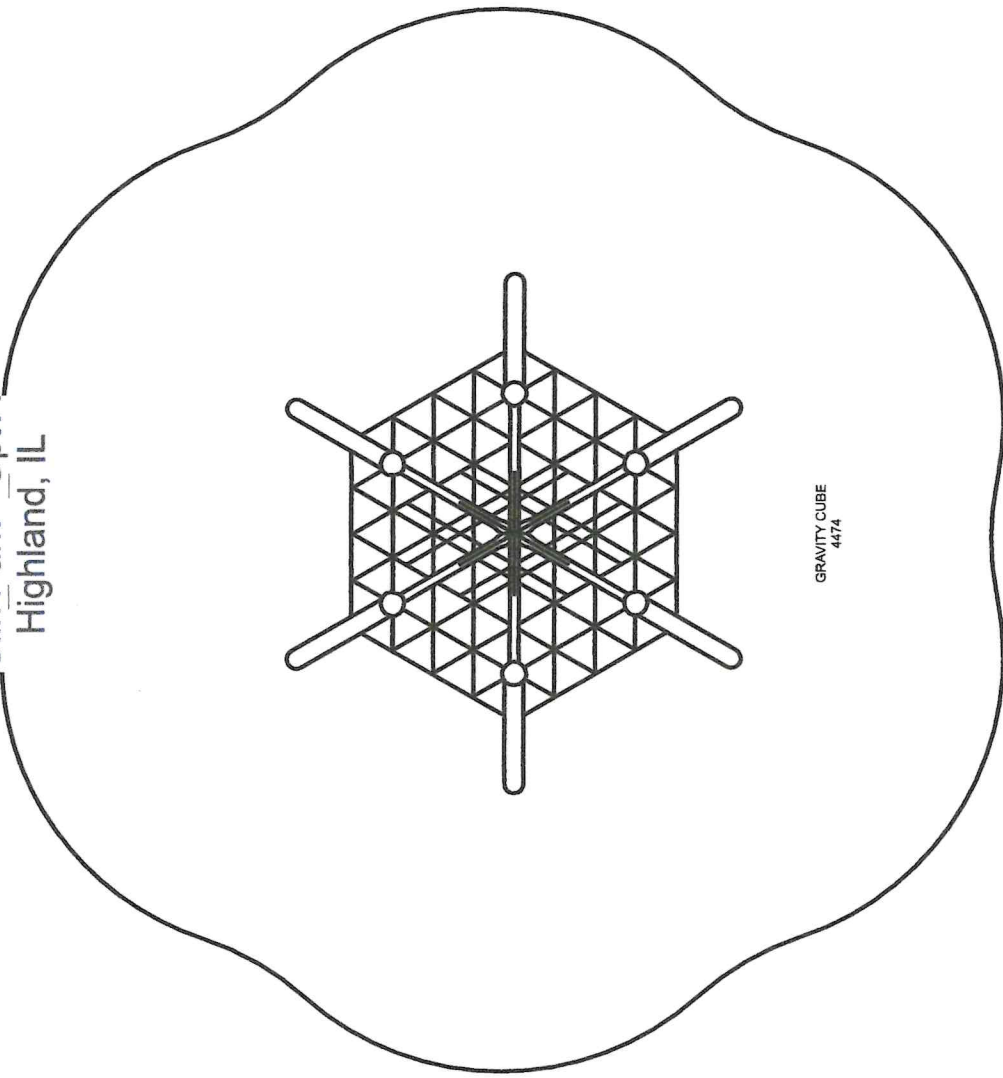

GRAVITY CUBE
4474



HUTCHINSON RECREATION & DESIGN
 1000 EDGEWATER PT. STE 101
 LAKE SAINT LOUIS, MO
 PHONE NO: (314) 436-5000
 FAX NO: (314) 332-2877
 GROUND SPACE: 12'-0" x 10'-0"
 PROTECTIVE AREA: 23'-6" x 22'-0"
 DRAWN BY: Brad Hutchinson
 DATE: 12/5/23

R0043_45265662628
 COMPLIES TO ASTM/CPSC
 COMPLIES TO ADA

To promote safe and proper equipment use by children, Miracle recommends the installation of either a Miracle safety sign or other appropriate safety signage near each play system's main entry point(s) to inform parents and supervisors of the age appropriateness of the play system and general rules for safe play.

THE PLAY COMPONENTS IDENTIFIED IN THIS PLAN ARE IPEMA CERTIFIED. THE USE AND LAYOUT OF THESE COMPONENTS CONFORM TO THE REQUIREMENTS OF ASTM F1487.

AN ENERGY ABSORBING PROTECTIVE SURFACE IS REQUIRED UNDER & AROUND ALL PLAY SYSTEMS



Playgrounds Fun & Easy!

PlayPower LT Farmington, Inc.
878 E. US Hwy 60
Monett, MO 65708
1-800-325-8828

Bill To:

Highland Parks and Recreation
ATTN: Mark Rosen
1 Nagle Drive
Highland IL 62249

Project Name & Location:

Highland Parks and Recreation
Rinderer Park
2548 Veterans Parkway
Highland IL 62249
Parts

Prepared by:

All Inclusive Rec
Sam Lawson
PO Box 72
Farmington, MO 63640
(309) 361-3364 (phone)
saml@allinclusiverec.com

Ship To Address:

Silver Lake Park
3099 Highland Park Rd.
Highland, IL 62249

End User:

Highland Parks and Recreation
Mark Rosen
(618) 651-8899
mdrosen@highlandil.gov

Quote Number:

Quote Date: 12/13/2023

Valid For: 30 Days From Quote Date

Table with 5 columns: Ref No., Description, Qty, Unit Price, Total Price. Rows include NRG Double Web Crawler, Engineered wooden safety surfacing, and Install Web Crawler and Fibar.

Subtotal: \$19,911.00
Freight: \$1,152.00
Total With(out) Tax: \$21,063.00

Make Purchase Orders Out To:
PlayPower LT Farmington, Inc.
878 E US Hwy 60
Monett, Missouri, USA 65708

Make Checks Payable To:
PlayPower LT Farmington, Inc.

Remit Purchase Orders To:
PlayPower LT Farmington, Inc
c/o All Inclusive Rec LLC
Sam Lawson
PO Box 72
Farmington MO 63640
saml@allinclusiverec.com
309-361-3364

Remit Checks To:
PlayPower LT Farmington, Inc.
P.O. Box 734155
Dallas, TX 75373-4155





GameTime c/o Cunningham Recreation
 PO Box 240981
 Charlotte, NC 28224
 800.438.2780
 704.525.7356 FAX

12/12/2023
 Quote #
 168405-01-01

City of Highland - Swings

City of Highland
 Attn: Mark Rosen
 1 Nagel Drive
 Highland, IL 62249
 Phone: 618-651-8899
 Fax:618-651-1387
 mdrosen@highlandil.gov

Ship to Zip 62249

Quantity	Part #	Description	Unit Price	Amount
1	38115	GameTime - Tree Swing	\$10,046.00	\$10,046.00
1	8910	GameTime - Belt Seat 3 1/2"Od(8910)	\$384.00	\$384.00
1	8696	GameTime - Encl Seat 3 1/2"(8696)	\$478.00	\$478.00
Contract: OMNIA #2017001134			Sub Total	\$10,908.00
			Discount	(\$740.68)
			Freight	\$1,501.41
			Total	\$11,668.73

Comments

* MATERIALS ONLY: Quotation does not include any site work, off-loading, storage, safety surfacing, or installation.

* Customer responsible for borders and safety surfacing (or priced upon request).

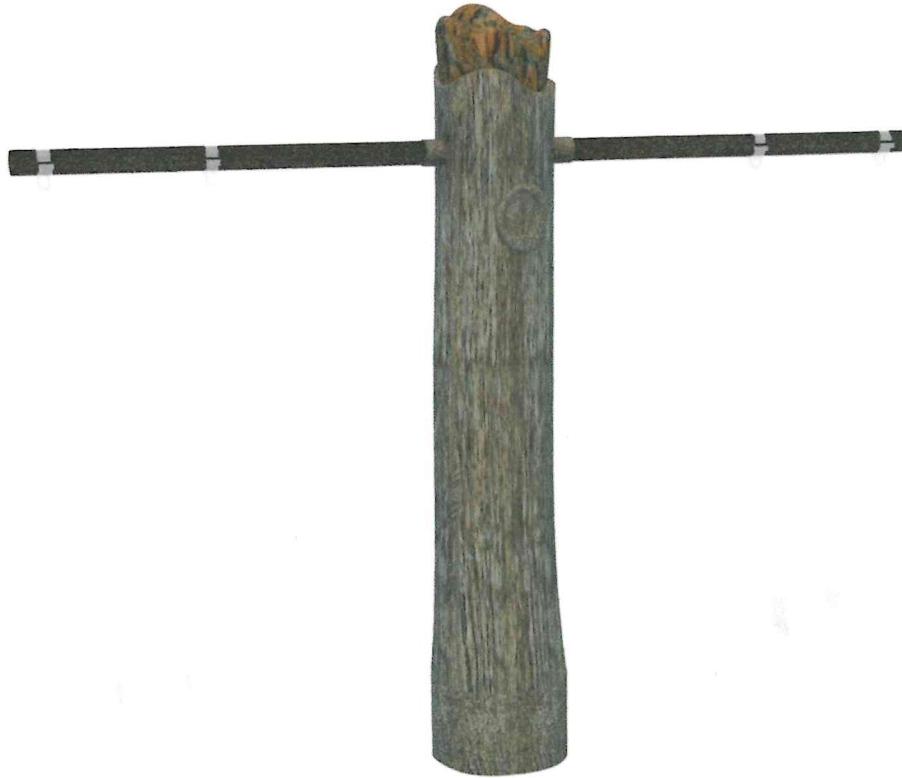

Tree Swing

Tree Swing Frame is a tree-themed swing frame that can hold up to two swing seats. This swing frame provides an eye-catching and memorable addition to any schools, parks, or other large youth organizations. Swing seats are sold separately.

FEATURES AND BENEFITS:

- Tree-theming adds character to any playground
- Promotes social interaction and processing sensory information
- Increases spatial awareness and helps develop gross and fine motor skills
- Enhances core strength

SPECIFICATIONS

Model 38115

Number:

Fall Height: 8' (2.44 m)

Use Zone: 31'-0" x 24'-0"
(9.45m x 7.31m)

GameTime offers a limited lifetime warranty on uprights, hardware, and connections. Visit gametime.com/warranty for full warranty information.

Payment

Order Summary

6 Items

6 x English Garden Hanging Baskets

Choose Size 22" Diameter
Self Watering Reservoir
Fiberglass Liner None



\$720.00

Subtotal

\$720.00

Shipping

--

Tax

\$0.00

Total (USD)

\$720.00



Customer

Email

Subscribe to our newsletter.

Already have an account? Sign in now

Or continue with



Shipping

Billing

ORDINANCE NO. _____

**ORDINANCE DECLARING PERSONAL PROPERTY OF THE CITY OF HIGHLAND
SURPLUS AND AUTHORIZING ITS SALE AND/OR DISPOSAL, SPECIFICALLY
PERSONAL PROPERTY FROM CITY HALL**

WHEREAS, the City of Highland, Madison County, Illinois (hereinafter “City”), is a non-home rule municipality duly established, existing and operating in accordance with the provisions of the Illinois Municipal Code (Section 5/1-1-1 et seq. of Chapter 65 of the Illinois Compiled Statutes); and

WHEREAS, 65 ILCS 5/11-76-4 provides that whenever a municipality in the state of Illinois owns any personal property which, in the opinion of a simple majority of the corporate authorities then holding office, is no longer necessary or useful to, or in the best interests of the municipality to keep, a majority of the corporate authorities at any regular or special meeting called for that purpose, may: (1) by Ordinance authorize the sale of such personal property in whatever manner they designate with or without advertising the sale; or (2) may authorize any municipal officer to convert that personal property to the use of the City; or (3) may authorize any municipal officer to convey or turn in any specified article of personal property as part payment on a new purchase of any similar article; and

WHEREAS, the City currently owns personal property from City Hall, including:

City Hall Surplus Property

- | | |
|-------------------------------------|-----------------------|
| (18) Lateral File Cabinets | (5) Office Chairs |
| (10) 4 drawer File Cabinets | (1) Postage Meter |
| (6) 2 Drawer File Cabinet | (2) Bathroom Fixtures |
| (2) 3 Drawer Wood Top File Cabinets | (1) Water Fountain |
| (40) Cubicle Walls | Kitchen Cabinets |
| (8) Office Desks | (2) Toliets |
| (3) Bookshelves | (1) Urinal |

(“City Hall Surplus Property”); and

WHEREAS, in the opinion of this City Council, the City Hall Surplus Property is no longer necessary or useful to, or in the best interests of the City to retain, and should be declared surplus personal property; and

WHEREAS, the City Manager has informed the City Council the City Hall Surplus Property will be sold for the highest value possible, or disposed of if they are deemed to have little or no value; and

WHEREAS, the City Manager has informed City Council the City Hall Surplus Property will no longer be needed by City due to City Hall being renovated; and

WHEREAS, City has determined the City Manager, or his designee, is permitted to sell the surplus personal property, specifically the City Hall Surplus Property, for the maximum value

that can be obtained, or to dispose of the surplus personal property where appropriate, to be determined solely by the City Manager, or his designee; and

WHEREAS, City has determined it to be in the best interest of public health, safety, general welfare and economic welfare to declare the aforementioned personal property surplus, and sell and/or dispose of the same.

NOW, THEREFORE, BE IT ORDAINED by the City Council of the City of Highland, Illinois, as follows:

Section 1. The foregoing recitals are incorporated herein as findings of the City Council of the City of Highland, Illinois.

Section 2. The City personal property, specifically the City Hall Surplus Property, is hereby declared no longer useful to the City or necessary for City purposes, that the City personal property is declared surplus, and that it is in the best interest of the City to sell and/or dispose of the same.

Section 3. The City Manager, or his designee, is directed and authorized to sell and/or dispose of the surplus personal property, as the City Manager, or his designee, sees fit.

Section 4. The City Manager, or his designee, is directed and authorized to sell the surplus personal property for the maximum value that can be obtained, or to dispose of the surplus personal property where appropriate, to be determined solely by the City Manager, or his designee.

Section 5. This Ordinance shall be known as Ordinance No. _____ and shall be in full force and effect from and after its passage, approval, and publication in pamphlet form as provided by law.

Passed by the City Council and approved by the Mayor of the City of Highland, Illinois, and deposited and filed in the office of the City Clerk on the _____ day of _____, 2024, the vote being taken by ayes and noes and entered upon the legislative record as follows:

AYES:

NOES:

APPROVED:

Kevin B. Hemann, Mayor, City of Highland
Madison County, Illinois

ATTEST:

Barbara Bellm, City Clerk, City of Highland
Madison County, Illinois



City of Highland
1115 Broadway, PO Box 218
Highland, IL 62249

To: Honorable Mayor Hemann and City Council

From: Chris Conrad-City Manager

Date: January 31, 2024

Re: Council chambers raised floor

I am submitting for your review and approval the proposal for raised floor solution for the council chambers.

I have attached the proposal from Indoff who the council previously approved our working with for the council chambers portion of this project.

This proposal is a sole source purchase for the purchase and installation of Teccrete TC1250 Raised Access Flooring System. This raised floor will be installed in the lowest level of the council chambers and will raise the current lowest level, identified in the attached drawing as level 4, to the same level as level 3. The raised floor solution will both allow easy access for current and future technology additions and installation; lessen the incline of the current ADA ramp into the room making the room easier to navigate for citizens with ADA concerns; and is a substantial enough product that it will easily blend naturally into the room.

Teccrete is a specialty product. In discussing this option both with our Indoff representative and the Project Manager from Korte Luitjohan on the larger city hall project, this would be an ideal and quality product for the purpose. The Korte Luitjohan representative was familiar with the product and has used in it other commercial applications; they further recommended that the City contract directly with the manufacturer for the purchase and installation of the product and advised that they could work with the company on any issues of transition between the raised and existing floor and the installation of carpet on the floor after installation.



City of Highland
1115 Broadway, PO Box 218
Highland, IL 62249

Budget Impact: The proposal cost is **\$33,050.00**. In discussion of the pricing with our KL project manager, he believed this to be a fair price and includes specific field measurements, purchase and installation of the raised floor.

As a reminder, the council chambers project was not part of the original bid contract with Korte and Luitjohan. Due to escalating pricing, we chose to wait and make sure we had the necessary funding available to add the council chambers project. So this contract is above the contracted amount with Korte-Luitjohan, but within the budget expectations for the overall project.

This proposal does not include AV equipment or monitors, those will be purchased in-house through our IT department or through a separate contract with Indoff who is consulting on the larger issue of AV solutions and sound remediation and masking.

We respectfully request the council approve the sole source purchase of this specialty raised floor product from Indoff/Teccrete.

I have attached for your review the floor drawing; the bid sheet from Indoff and the product catalog from Teccrete.

RESOLUTION NO. _____

RESOLUTION WAIVING COMPETITIVE BIDDING REQUIREMENT AND APPROVING AND AUTHORIZING THE EXECUTION OF AN AGREEMENT WITH INDOFF, ON BEHALF OF TECCRETE, FOR PURCHASE OF PRODUCTS, MATERIALS, AND ALL LABOR FOR A RAISED FLOOR SOLUTION SYSTEM IN THE CITY COUNCIL CHAMBERS

WHEREAS, the City of Highland, Madison County, Illinois (hereinafter “City”), is a non-home rule municipality duly established, existing and operating in accordance with the provisions of the Illinois Municipal Code (Section 5/1-1-1 et seq. of Chapter 65 of the Illinois Compiled Statutes); and

WHEREAS, City Council has been advised of the need for a new raised floor in the City Council Chambers; and

WHEREAS, the City Manager has informed the City Council that the Teccrete raised floor will be installed in the lowest level of the council chambers and will raise the current lowest level to the same level as the current level 3; and

WHEREAS, the City Manager has informed the City Council that the Teccrete raised floor solution will allow easy access for current and future technology additions and installation in the Council Chambers, lessen the incline of the current ADA ramp into the Council Chambers making the room easier to navigate for citizens with ADA concerns, and is a substantial enough product that it will easily blend naturally into the Council Chambers; and

WHEREAS, Indoff has provided a proposal to for the purchase and installation of the TC 1250 Teccrete Raised Access Floor System for a price of \$33,050.00 (“Indoff Proposal”) (*See Exhibit A*); and

WHEREAS, City Council deems it to be in the best interests of City to waive the competitive-bidding requirement and to agree to the Indoff Proposal as attached (*See Exhibit A*); and

WHEREAS, the City Council also finds that the City Manager and/or Mayor should be authorized and directed, on behalf of the City of Highland, to execute whatever documents are necessary to waive the competitive-bidding requirement and agree to the Indoff Proposal as attached (*See Exhibit A*).

NOW, THEREFORE, BE IT RESOLVED, by the City Council of the City of Highland as follows:

Section 1. The foregoing recitals are incorporated herein as findings of the City Council of the City of Highland, Illinois.

Section 2. City shall waive normal and ordinary bidding procedures, and the Indoff Proposal (*See Exhibit A*) is approved.

Section 3. The City Manager and/or Mayor is authorized and directed, on behalf of the City of Highland, to execute and date whatever documents may be necessary enter the Indoff Proposal (*See Exhibit A*) for \$33,050.00

Section 4. This Resolution shall be known as Resolution No. _____ and shall be effective upon its passage and approval in accordance with law.

Passed by the City Council of the City of Highland, Illinois, and deposited and filed in the Office of the City Clerk, on the _____ day of _____, 2024, the vote being taken by ayes and noes, and entered upon the legislative records, as follows:

AYES:

NOES:

APPROVED:

Kevin B. Hemann
Mayor
City of Highland
Madison County, Illinois

ATTEST:

Barbara Bellm
City Clerk
City of Highland
Madison County, Illinois



QUOTE

Quote Date 11/09/2023

8691651

Carol Eckhoff
Email: carol.eckhoff@indoff.com
Phone: 303-995-5272 Fax:

Bill To: City of Highland
12990 Troxler Avenue
Highland, IL 62249

Ship To: City of Highland
12990 Troxler Avenue
Highland, IL 62249

Customer	Purchase Order Number	Department/Tag
419574	8 25 2023	City Hall raised floor
Sales Person	Date Requested	
Carol Eckhoff	2023-11-09	

Customer Instructions

Qty	UM	Item	Description	Unit Price	Extended Price
10.00	HR	Design Programming	field measure and design	30.00	300.00
1.00	LO	Teccrete raised floor	INSTALLATION OF THE TC1250 TECCRETE RAISED ACCESS FLOOR SYSTEM. FLOOR PANELS TO BE BARE NO FINISH INSTALLED ON AN ALL STEEL CORNER LOCK PEDESTAL SYSTEM RAMPS: MODIFICATION TO BE BUILT WITH RAISED FLOOR COMPONENTS PER PLAN STEP: NOT INCLUDED FASCIA: NOT INLCUDED GUARDRAILS ALUM: NOT INCL. HANDRAILS ALUM: NOT INCL FLOOR FINISHES: NOT INCLUDED BY OTHERS CUT OUTS: UP TO 6 3 GROMMETS INCLUDED AIR FLOW PANELS: NOT INCLUDED PANEL LIFTER: 2 - INCLUDED PRE-MARK FOR PEDESTAL: NOT INCLUDED FLOOR SEALER: NOT INCLUDED BY OTHERS FLOOR PROTECTION: KRAFT PAPER INSTALLED ONE TIME INCLUDED EXCLUSIONS: ANY AND ALL MECHANICAL OR ELECTRICAL DEVICES, PERFORATED PANELS OR AIR FLOW DEVICES, COVEBASE, GROUNDING, CUT OUTS, LIFTS AND HOISTS TO UPPER FLOORS, CARPET, BOND, AFTER HOURS WORK, PLENUM DIVIDER, SALES TAX, BOND CONCRETE ANCHORS, UNION LABOR	32,750.00	32,750.00

Sub-total	33,050.00
* Estimated Tax	0.00
Quote Total	(USD) 33,050.00

Thank you for your business and your support!

HIGHLAND CITY
COUNCIL CHAMBERS

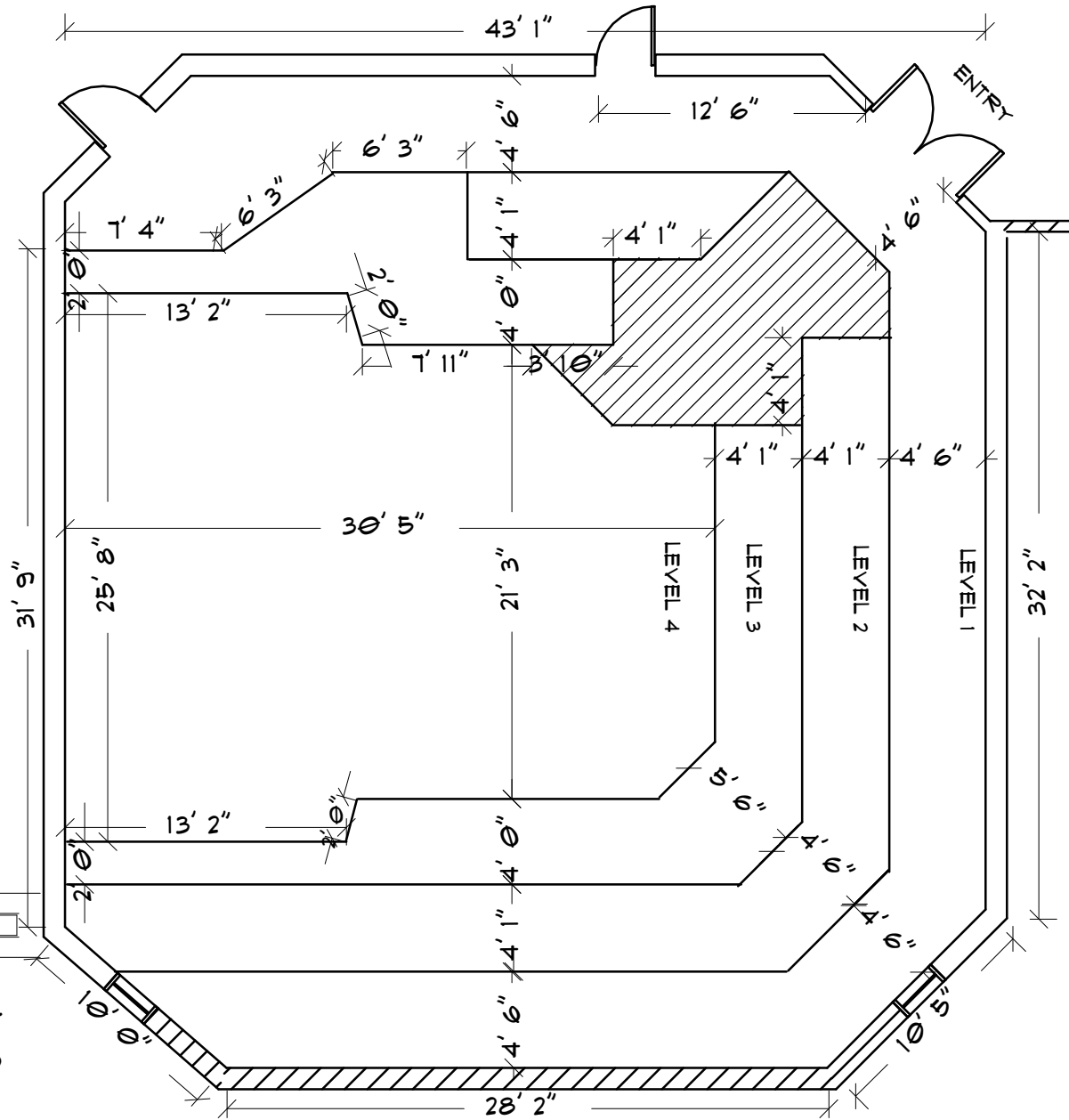
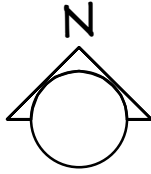



THE TECRETE SYSTEM

An industry leader for over 30 years the TecCrete system is the original concrete surface panel. It has become the leading choice for architects and developers who demand best in class performance and value for their critical building systems. TecCrete is available in both corner-lock and gravity-held configurations.

UNDERSTRUCTURE

Bolted stringer and corner-lock systems

PANEL DIMENSIONS

Imperial - 24" x 24"

THICKNESS

Nominal 1.125" or 1.5"



FEATURES

- Steel pan and concrete composite construction delivers industry leading static and dynamic loading performance
- Solid feel underfoot and high level of acoustical performance
- Height Adjustable from 3"-54"
- Pedestal lock and positioning system for easier installation
- Flat bottom and uniform thickness maximizes underfloor clearance
- 58% recycled content (LEED MR 4.1 & 4.2)
- Greenguard Gold Certification
- Industry Leading 3 Year Standard Structural Warranty

TECCRETE

ACCESSORY CUT-OUTS

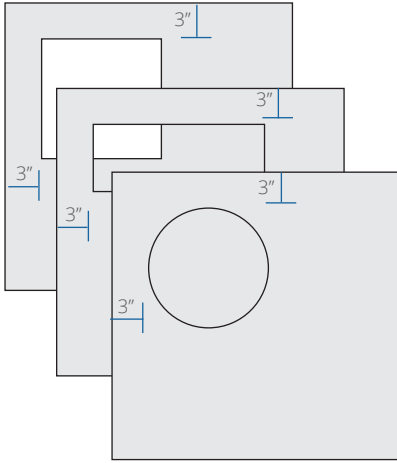

Material Properties

Concentrated Load (min)

Uniform Load (min)

Rolling Load
(10/10,000 Pass)

TC 1250

1250 lbs (567 kg)

600 lbs (272 kg)

1300 lbs /900 lbs
(590 kg/408 kg)

TC 1500

1500 lbs (680 kg)

700 lbs (318 kg)

1500 lbs /1250 lbs
(680 kg/567 kg)

TC 1500SL

1500 lbs (680 kg)

700 lbs (318 kg)

1500 lbs /1250 lbs
(680 kg/567 kg)

TC 2000

2000 lbs (907 kg)

800 lbs (363 kg)

1750 lbs /2000 lbs
(794 kg/907 kg)

TC 2500

2500 lbs (1134 kg)

900 lbs (408 kg)

2000lbs /2000 lbs
(907 kg/907 kg)

CORNER-LOCK SYSTEM

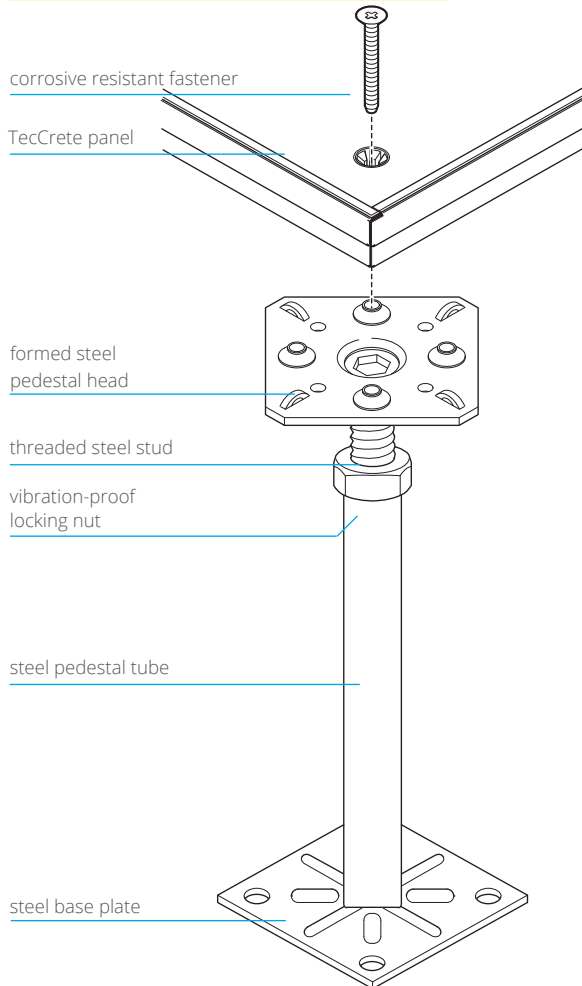

BOLTED STRINGER SYSTEM

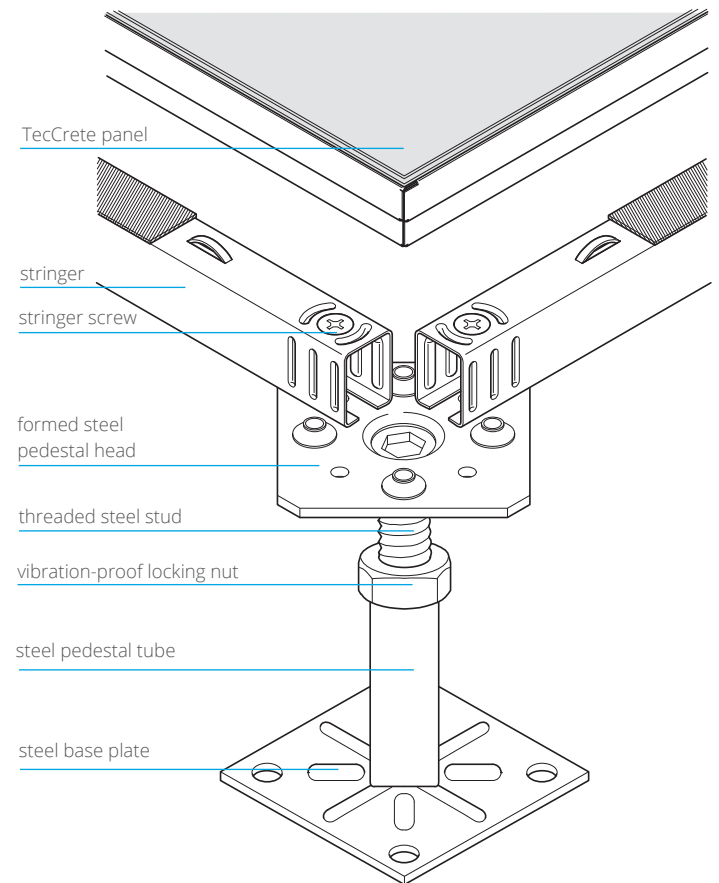



Memo To: Chris Conrad, City Manager
From: Angela Imming, Dir. Technology and Innovation
Date: Jan. 21, 2024
Subject: Joint Purchase Program for Security Appliance Licenses

Recommendation:

I respectfully recommend council approval to utilize the State of Illinois Joint Purchasing Program to renew our support for the Palo Alto security appliance.

Discussion:

The Palo Alto solution offers security both at the wide area network layer (at the point where the Internet reaches HCS) by recognizing ddos attack algorithms and stopping them before hitting the City or HCS customers. It offers zero day threat malware protection (threats that are as new as that very day) as well as protection to our servers, our PCs and general city network.

Financial Impact:

CDW is an approved vendor under the State of Illinois Joint Purchasing Program. Ideally, and as we offer security services to other commercial customers, we would have a pair of appliances to ensure high availability. However, the budget for 2023-2024 did include and was approved with this purchase. The lowest quote is for a single appliance for \$50,545.40.

The Joint Purchasing Program is outlined in the City of Highland's purchasing policy copied below:

State of Illinois

City employees are authorized to obtain goods and services using the State of Illinois Joint Purchasing program. When available through the State program, it is not necessary for City employees to obtain quotes or to competitively bid the goods or services which are sought. Employees shall be responsible, however, for ensuring that the goods or services are of a quality sufficient to meet the City's needs and that pricing is competitive.

When making purchases using the State's assigned vendor, employees shall submit a purchase order to the vendor directly and shall include the State of Illinois contract number and the City's assigned Joint Purchasing member I.D. number (L2590) on the purchase order. This information should be included on the purchase order.

RESOLUTION NO. _____

**RESOLUTION WAIVING COMPETITIVE BIDDING REQUIREMENT AND
APPROVING AND AUTHORIZING THE EXECUTION OF A PURCHASE
AGREEMENT TO PURCHASE A PALO ALTO SECURITY DEVICE THROUGH THE
STATE OF ILLINOIS JOINT PURCHASING PROGRAM AS A SOLE SOURCE
PURCHASE**

WHEREAS, the City of Highland, Madison County, Illinois (hereinafter “City”), is a non-home rule municipality duly established, existing and operating in accordance with the provisions of the Illinois Municipal Code (Section 5/1-1-1 et seq. of Chapter 65 of the Illinois Compiled Statutes); and

WHEREAS, City Council has been advised of the need for a new Palo Alto security appliance which will offer security at the wide area network layer (at the point where the Internet reaches HCS) by recognizing dDOS attack algorithms, and stopping said algorithms before hitting the City or HCS customers; and

WHEREAS, pursuant to 30 ILCS 525/4.2:

Sec. 4.2. Any governmental unit may, without violating any bidding requirement otherwise applicable to it, procure supplies and services under any contract let by the State pursuant to lawful procurement procedures.

(See State of Illinois Governmental Joint Purchasing Act; 30 ILCS 525 *et seq.*); and

WHEREAS, pursuant to the City of Highland purchasing policy:

State of Illinois

City employees are authorized to obtain goods and services using the State of Illinois Joint Purchasing program. When available through the State program, it is not necessary

for City employees to obtain quotes or to competitively bid the goods or services which are sought. Employees shall be responsible, however, for ensuring that the goods or services are of a quality sufficient to meet the City's needs and that pricing is competitive.

When making purchases using the State's assigned vendor, employees shall submit a purchase order to the vendor directly and shall include the State of Illinois contract number and the City's assigned Joint Purchasing member I.D. number on the purchase order. This information should be included on the purchase order.

(See City of Highland Purchasing Policy); and

WHEREAS, the Director of Technology and Innovation has recommended utilizing the State of Illinois Joint Purchasing Program to purchase the Palo Alto security appliance; and

WHEREAS, the Director of Technology and Innovation has informed City Council that CDW is a registered vendor under the State of Illinois Joint Purchasing program; and

WHEREAS, the Director of Technology and Innovation has informed City Council that a new Palo Alto security device can be purchased from the State of Illinois Joint Purchasing program through the CDW registered vendor for \$50,545.40 ("Quote") (See CDW Quote attached hereto as **Exhibit A**); and

WHEREAS, City Council deems it to be in the best interests of City to waive the competitive-bidding requirement and to purchase the Palo Alto security device through the State of Illinois Joint Purchasing program pursuant to the Quote (**Exhibit A**) as a sole source purchase; and

WHEREAS, the City Council also finds that the City Manager and/or Mayor should be authorized and directed, on behalf of the City of Highland, to execute whatever documents are necessary to waive the competitive-bidding requirement and to purchase the Palo Alto security device through the State of Illinois Joint Purchasing program pursuant to the Quote (**Exhibit A**) as a sole source purchase.

NOW, THEREFORE, BE IT RESOLVED, by the City Council of the City of Highland as follows:

Section 1. The foregoing recitals are incorporated herein as findings of the City Council of the City of Highland, Illinois.

Section 2. The purchase of the Palo Alto security device through the State of Illinois Joint Purchasing program pursuant to the Quote (**Exhibit A**) as a sole source purchase is approved.

Section 3. The City Manager and/or Mayor is authorized and directed, on behalf of the City of Highland, to execute and date whatever documents may be necessary to purchase the Palo Alto security device through the State of Illinois Joint Purchasing program pursuant to the Quote (**Exhibit A**) as a sole source purchase.

Section 4. This Resolution shall be known as Resolution No. _____ and shall be effective upon its passage and approval in accordance with law.

Passed by the City Council of the City of Highland, Illinois, and deposited and filed in the Office of the City Clerk, on the _____ day of _____, 2024, the vote being taken by ayes and noes, and entered upon the legislative records, as follows:

AYES:

NOES:

APPROVED:

Kevin B. Hemann, Mayor
City of Highland
Madison County, Illinois

ATTEST:

Barbara Bellm, City Clerk
City of Highland
Madison County, Illinois



Thank you for choosing CDW. We have received your quote.

Hardware Software Services IT Solutions Brands Research Hub

QUOTE CONFIRMATION

MIKE RUSSELL,

Thank you for considering CDW•G for your technology needs. The details of your quote are below. **If you are an eProcurement or single sign on customer, please log into your system to access the CDW site.** You can search for your quote to retrieve and transfer back into your system for processing.

For all other customers, click below to convert your quote to an order.

This quote is subject to CDW's Third Party Cloud Services Order Form Terms and Conditions set forth at <https://www.cdw.ca/content/cdwca/en/terms-conditions/third-party-cloud-services-order-form-terms-and-conditions.html>.

Convert Quote to Order

QUOTE #	QUOTE DATE	QUOTE REFERENCE	CUSTOMER #	GRAND TOTAL
NSBV539	1/17/2024	PALO	4299026	\$50,545.40

QUOTE DETAILS

ITEM	QTY	CDW#	UNIT PRICE	EXT. PRICE
Palo Alto Networks Advanced URL Filtering - subscription license renewal (1 Mfg. Part#: PAN-PA-5220-ADVURL-HA2-R Electronic distribution - NO MEDIA Contract: MARKET	1	6744350	\$11,410.83	\$11,410.83
Palo GlobalProtect Gateway for PA-5220 - subscription license renewal (1 ye Mfg. Part#: PAN-PA-5220-GP-HA2-R UNSPSC: 43233204 Contract: MARKET	1	4757496	\$7,607.22	\$7,607.22
Palo Partner Enabled Premium Support - extended service agreement (renewal) Mfg. Part#: PAN-SVC-BKLN-5220-R UNSPSC: 81111811 Contract: MARKET	1	5454969	\$9,474.96	\$9,474.96
Palo Alto Networks Advanced Threat Prevention - subscription license renewa Mfg. Part#: PAN-PA-5220-ATP-HA2-R Electronic distribution - NO MEDIA Contract: MARKET	1	7068711	\$11,410.83	\$11,410.83
Palo Alto Networks Advanced WildFire - subscription license renewal (1 year Mfg. Part#: PAN-PA-5220-AWF-HA2-R Electronic distribution - NO MEDIA Contract: MARKET	1	7344484	\$10,641.56	\$10,641.56

These services are considered Third Party Services, and this purchase is subject to CDW's [Third Party Cloud Services Terms and Conditions](#),

unless you have a written agreement with CDW covering your purchase of products and services, in which case this purchase is subject to such other written agreement.

The third-party Service Provider will provide these services directly to you pursuant to the Service Provider's standard terms and conditions or such other terms as agreed upon directly between you and the Service Provider. The Service Provider, not CDW, will be responsible to you for delivery and performance of these services. Except as otherwise set forth in the Service Provider's agreement, these services are non-cancellable, and all fees are non-refundable.

SUBTOTAL	\$50,545.40
SHIPPING	\$0.00
SALES TAX	\$0.00
GRAND TOTAL	\$50,545.40

PURCHASER BILLING INFO	DELIVER TO
Billing Address: CITY OF HIGHLAND ATTN: ACCOUNTS PO BOX 218 HIGHLAND, IL 62249-0218 Phone: (618) 654-9891 Payment Terms: NET 30-VERBAL	Shipping Address: CITY OF HIGHLAND MIKE RUSSELL 192 WOODCREST DR HIGHLAND, IL 62249-1266 Shipping Method: DROP SHIP-GROUND
	Please remit payments to: CDW Government 75 Remittance Drive Suite 1515 Chicago, IL 60675-1515



Sales Contact Info

Elijah Johnson | (866) 339-3646 | elijah@cdwg.com

LEASE OPTIONS			
FMV TOTAL	FMV LEASE OPTION	BO TOTAL	BO LEASE OPTION
\$50,545.40	\$1,355.12/Month	\$50,545.40	\$1,565.39/Month

Monthly payment based on 36 month lease. Other terms and options are available. Contact your Account Manager for details. Payment quoted is subject to change.

Why finance?

- Lower Upfront Costs. Get the products you need without impacting cash flow. Preserve your working capital and existing credit line.
- Flexible Payment Terms. 100% financing with no money down, payment deferrals and payment schedules that match your company's business cycles.
- Predictable, Low Monthly Payments. Pay over time. Lease payments are fixed and can be tailored to your budget levels or revenue streams.
- Technology Refresh. Keep current technology with minimal financial impact or risk. Add-on or upgrade during the lease term and choose to return or purchase the equipment at end of lease.
- Bundle Costs. You can combine hardware, software, and services into a single transaction and pay for your software licenses over time! We know your challenges and understand the need for flexibility.

General Terms and Conditions:

This quote is not legally binding and is for discussion purposes only. The rates are estimate only and are based on a collection of industry data from numerous sources. All rates and financial quotes are subject to final review, approval, and documentation by our leasing partners. Payments above exclude all applicable taxes. Financing is subject to credit approval and review of final equipment and services configuration. Fair Market Value leases are structured with the assumption that the equipment has a residual value at the end of the lease term.

Need Help?



My Account



Support



Call 800.800.4239

[About Us](#) | [Privacy Policy](#) | [Terms and Conditions](#)

This order is subject to CDW's Terms and Conditions of Sales and Service Projects at

<http://www.cdw.com/content/terms-conditions/product-sales.aspx>

For more information, contact a CDW account manager.

© 2024 CDW•G LLC, 200 N. Milwaukee Avenue, Vernon Hills, IL 60061 | 800.808.4239

ORDINANCE NO. _____

AN ORDINANCE AMENDING CHAPTER 6, OF THE CODE OF ORDINANCES, CITY OF HIGHLAND, ALCOHOLIC LIQUOR, TO INCREASE THE NUMBER OF D1 LIQUOR LICENSES TO EIGHT, AND TO INCREASE THE NUMBER OF D2 LIQUOR LICENSES TO TWELVE

WHEREAS, the City of Highland, Madison County, Illinois (hereinafter “City”), is a non-home rule municipality duly established, existing and operating in accordance with the provisions of the Illinois Municipal Code (Section 5/1-1-1 et seq. of Chapter 65 of the Illinois Compiled Statutes); and

WHEREAS, City has determined it necessary to provide flexibility and additional authority to the Liquor Commissioner to issue and enforce City liquor licenses; and

WHEREAS, City has authority to define, regulate, issue, and collect fees associated with liquor licenses; and

WHEREAS, City has authority to determine the number, kind, and classification of [liquor] licenses to be issued . . . 235 ILCS 5/4-1; and

WHEREAS, City has the authority to establish [liquor] license fees for the various kinds of licenses to be issued. 235 ILCS 5/4-1; and

WHEREAS, Chapter 6 of the City Code of Ordinances, Alcoholic Liquor, currently defines “Restaurant” as follows:

Restaurant means any public place kept, used, maintained, advertised, and held out to the public as a place where meals are served, and where meals actually are served and regularly served, such space being provided with adequate and sanitary kitchen and dining room equipment and capacity and having employed therein a sufficient number and kind of employees to prepare, cook and serve suitable food for its guests. (See 235 ILCS Sec.5/1-3.23)

and;

WHEREAS, Chapter 6 of the City Code of Ordinances, Alcoholic Liquor, currently defines Class “D1” liquor licenses as follows:

6-2-6 CLASSIFICATION - FEE – LIMITATION.

Every person engaged in the retail sale of alcoholic liquor in the city shall pay an annual license fee. Such licenses shall be divided into the following classes:

(4) Class "D1" and class "D2" licenses: Restaurants. Class "D1" and class "D2" licenses shall authorize the sale of alcoholic liquor of all varieties at retail for

consumption on the premises in conjunction with the operation of a restaurant, as well as retail sale of alcoholic liquor in the original package off premises. In addition:

- a. Class "D1" license will not permit the licensee to operate video gaming terminals upon the premises. The annual fee for such license shall be \$500.00.
- b. Class "D2" license may permit the licensee to operate video gaming terminals upon the premises. Class "D2" licenses may permit the licensee to operate video gaming terminals upon the premises, subject to the following conditions:
 1. Any person who displays a video gaming terminal for play or operation by the public shall have, as a prerequisite to receiving any class "D2" license from the city, a valid license issued by the state gaming board for each such video gaming terminal. The cancellation, suspension, or revocation of any such license by the state gaming board shall result in the automatic cancellation, suspension, or revocation of the city's Class "D2" license without refund of any portion of the license fee. An applicant for the class "D2" license shall submit to the city finance director a copy of the license issued by the state gaming board for each video gaming terminal to be played or operated on the licensed premises.
 2. Any liquor license issued by the city to any liquor licensee pursuant to this chapter, including but not limited to any licensed fraternal establishment or licensed veterans establishment (as defined in the Video Gaming Act, 230 ILCS 40/5), that displays a video gaming terminal for play or operation within its premises in violation of this subsection shall be immediately revoked.
 3. No more than six video gaming terminals may be located on any class "D2" licensee's premises.
 4. Every class "D2" licensee shall comply with the provisions of the Video Gaming Act, 230 ILCS 40/1 et seq., as amended, and all rules, regulations, and restrictions imposed by the state gaming board, as amended.
 5. The operation of video gaming terminals shall not be permitted during the hours alcoholic liquor sales are prohibited.
 6. Video gaming shall be located in a clearly demarcated area that is restricted to persons over 21 years of age.

The annual fee for a class "D2" license shall be \$500.00.

and

WHEREAS, Chapter 6 of the City Code of Ordinances, Alcoholic Liquor, currently limits the number of City Liquor licenses issued as follows:

6-2-6 CLASSIFICATION - FEE – LIMITATION.

(9) Limitation on Number of Licenses Issued.

- a. By separate ordinance, the City Council may set a limitation upon the number of licenses to sell alcoholic liquor at retail to be issued for each above classification of license.
- b. As licenses are revoked, expire without renewal, or for any reason cease to exist, the total number of licenses for each classification shall automatically be reduced until the total number of licenses issued for each class shall not exceed the number authorized by the City Council.
- c. If any establishment selling alcoholic liquor is annexed to and becomes a part of the City, the various alcoholic liquor licenses as enumerated in this Section shall be increased in number only in the class which the annexed establishment qualifies provided the annexed establishment holds a current valid liquor license from the governmental entity from which the establishment was annexed and from the State of Illinois.
- d. The following limits are established on the number of licenses to sell alcoholic beverages and/or permit video gaming in the City:

Class A1	5
Class A2	6
Class B	5 (Unlimited)
Class C	6 (Unlimited)
Class D1	7
Class D2	10
Class E	2 (Unlimited)
Class F	2 (Unlimited)
Class G	2
Class H1	0 (Unlimited)
Class H2	1

WHEREAS, City has determined it to be in the best interests of public health, safety, general welfare and economic welfare to increase the number of D1 liquor licenses from seven (7) to eight (8) licenses; and

WHEREAS, City has determined the additional D1 liquor license will be issued to a qualified applicant by way of separate resolution.

WHEREAS, City has determined it to be in the best interests of public health, safety, general welfare and economic welfare to increase the number of D2 liquor licenses from ten (10) to twelve (12) licenses; and

WHEREAS, City has determined the additional D2 liquor licenses will be issued to qualified applicants by way of separate resolution.

NOW, THEREFORE, BE IT ORDAINED, by the City Council of the City of Highland as follows:

Section 1. The foregoing recitals are incorporated herein as findings of the City Council of the City of Highland, Illinois.

Section 2. Chapter 6, of the Code of Ordinances, City of Highland, shall now read:

6-2-6 CLASSIFICATION - FEE – LIMITATION.

(9) Limitation on Number of Licenses Issued.

- a. By separate ordinance, the City Council may set a limitation upon the number of licenses to sell alcoholic liquor at retail to be issued for each above classification of license.
- b. As licenses are revoked, expire without renewal, or for any reason cease to exist, the total number of licenses for each classification shall automatically be reduced until the total number of licenses issued for each class shall not exceed the number authorized by the City Council.
- c. If any establishment selling alcoholic liquor is annexed to and becomes a part of the City, the various alcoholic liquor licenses as enumerated in this Section shall be increased in number only in the class which the annexed establishment qualifies provided the annexed establishment holds a current valid liquor license from the governmental entity from which the establishment was annexed and from the State of Illinois.
- d. The following limits are established on the number of licenses to sell alcoholic beverages and/or permit video gaming in the City:

Class A1	5
Class A2	6
Class B	5 (Unlimited)
Class C	6 (Unlimited)
Class D1	8
Class D2	12
Class E	2 (Unlimited)
Class F	2 (Unlimited)
Class G	2
Class H1	0 (Unlimited)
Class H2	1

Section 3. The number of D1 liquor licenses will be increased from seven (7) licenses to eight (8) licenses.

Section 4. The additional D1 liquor license will be issued to a qualified applicant by way of separate resolution.

Section 5. The number of D2 liquor licenses will be increased from ten (10) licenses to twelve (12) licenses.

Section 6. The additional D2 liquor licenses will be issued to qualified applicants by way of separate resolutions.

Section 7. This ordinance shall be in full force and effect from and after its passage, approval, and publication in pamphlet form as provided by law.

Passed by the City Council and approved by the Mayor of the City of Highland, Illinois, and deposited and filed in the office of the City Clerk on the ____ day of _____, 2024, the vote being taken by ayes and noes and entered upon the legislative record as follows:

AYES:

NOES:

APPROVED:

Kevin B. Hemann, Mayor
City of Highland
Madison County, Illinois

ATTEST:

Barbara Bellm, City Clerk
City of Highland
Madison County, Illinois

RESOLUTION NO. _____

RESOLUTION ISSUING A “D1” LIQUOR LICENSE TO GAUCHOS ARGENTINIAN STEAKHOUSE LLC, PURSUANT TO CHAPTER 6, OF THE CODE OF ORDINANCES, CITY OF HIGHLAND, ENTITLED ALCOHOLIC LIQUOR

WHEREAS, the City of Highland, Madison County, Illinois (hereinafter “City”), is a non-home rule municipality duly established, existing and operating in accordance with the provisions of the Illinois Municipal Code (Section 5/1-1-1 et seq. of Chapter 65 of the Illinois Compiled Statutes); and

WHEREAS, City has determined it necessary to provide flexibility and additional authority to the Liquor Commissioner to issue and enforce City liquor licenses; and

WHEREAS, City has authority to define, regulate, issue, and collect fees associated with liquor licenses; and

WHEREAS, City has authority to determine the number, kind, and classification of [liquor] licenses to be issued . . . 235 ILCS 5/4-1; and

WHEREAS, City has the authority to establish [liquor] license fees for the various kinds of licenses to be issued. 235 ILCS 5/4-1; and

WHEREAS, Gauchos Argentinian Steakhouse LLC (hereinafter “Gauchos”) desires to obtain a “D1” restaurant (no video gaming) liquor license; and

WHEREAS, Gauchos submitted an Application for a Retail Liquor Dealer’s License to City (*see* Application attached hereto as **Exhibit A**); and

WHEREAS, Chapter 6 of the City Code of Ordinances, Alcoholic Liquor, currently defines “Restaurant” as follows:

Restaurant means any public place kept, used, maintained, advertised, and held out to the public as a place where meals are served, and where meals actually are served and regularly served, such space being provided with adequate and sanitary kitchen and dining room equipment and capacity and having employed therein a sufficient number and kind of employees to prepare, cook and serve suitable food for its guests. (*See* 235 ILCS Sec.5/1-3.23)

and;

WHEREAS, Chapter 6 of the City Code of Ordinances, Alcoholic Liquor, currently defines Class “D1” liquor licenses as follows:

6-2-6 CLASSIFICATION - FEE – LIMITATION.

Every person engaged in the retail sale of alcoholic liquor in the city shall pay an annual license fee. Such licenses shall be divided into the following classes:

(4) Class "D1" and class "D2" licenses: Restaurants. Class "D1" and class "D2" licenses shall authorize the sale of alcoholic liquor of all varieties at retail for consumption on the premises in conjunction with the operation of a restaurant, as well as retail sale of alcoholic liquor in the original package off premises. In addition:

a. Class "D1" license will not permit the licensee to operate video gaming terminals upon the premises. The annual fee for such license shall be \$500.00.

and

WHEREAS, Gauchos's Application for Retail Liquor Dealer's License (**Exhibit A**) has been approved by the Mayor / Liquor Commissioner; and

WHEREAS, City Council recently passed an Ordinance increasing the number of "D1" liquor licenses available from seven (7) to eight (8); and

WHEREAS, City has determined there is one "D1" liquor license currently available to be issued to Gauchos; and

WHEREAS, City has determined it to be in the best interests of public health, safety, general welfare and economic welfare to issue Gauchos a "D1" Liquor License; and

WHEREAS, the Liquor Commissioner reserves the right to ensure all aspects of City Code have been complied with prior to issuance of the "D1" liquor license to Gauchos; and

WHEREAS, the City Manager and/or Mayor is authorized and directed to execute any documents necessary to issue a "D1" liquor license to Gauchos.

NOW, THEREFORE, BE IT RESOLVED, by the City Council of the City of Highland as follows:

Section 1. The foregoing recitals are incorporated herein as findings of the City Council of the City of Highland, Illinois.

Section 2. City shall issue a "D1" liquor license to Gauchos.

Section 3. This resolution shall be in full force and effect from and after its passage, approval, and publication in pamphlet form as provided by law.

Passed by the City Council and approved by the Mayor of the City of Highland, Illinois, and deposited and filed in the office of the City Clerk on the ____ day of _____, 2024, the vote being taken by ayes and noes and entered upon the legislative record as follows:

AYES:

NOES:

APPROVED:

Kevin B. Hemann, Mayor
City of Highland
Madison County, Illinois

ATTEST:

Barbara Bellm, City Clerk
City of Highland
Madison County, Illinois

APPLICATION
FOR RETAIL LIQUOR DEALERS LICENSE
CITY OF HIGHLAND

This application properly completed and signed must be filed with the City Clerk and must be accompanied by a remittance in the proper amount, made payable to the City of Highland.

The undersigned individual or partnership hereby makes application for a RETAIL LIQUOR DEALERS LICENSE and submits the following information:

1. Applicant: OSCAR FARIÑA
(GIVE NAME OF INDIVIDUAL OR NAMES OF PARTNERS/CORPORATION ---TYPE OR PRINT CLEARLY)
 2. Trade, Partnership or Assumed Name Gauchos ARGENTINIAN STEAKHOUSE LLC
 3. Give date partnership/corporation was formed under name given on Line 1: 9 - 26 - 2019
Month Day Year
 4. Location of above place of business 1014 Laurel St, Highland IL 62249
NUMBER STREET CITY STATE ZIP CODE
 5. Has your assumed name been filed with the County Clerk?

 6. Are alcoholic liquors stored but not sold at any location other than the one given above?
NO
- If "yes", give location: _____
- | NUMBER | STREET | CITY | STATE | ZIP CODE |
|--------|--------|------|-------|----------|
|--------|--------|------|-------|----------|
7. Check principal kind of business:

<input checked="" type="checkbox"/> Restaurant	<input type="checkbox"/> Tavern	
<input type="checkbox"/> Hotel	<input type="checkbox"/> Grocery Store	<input type="checkbox"/> Amusement Place
<input type="checkbox"/> Club	<input type="checkbox"/> Package Store	<input type="checkbox"/> Department Store
<input type="checkbox"/> Country Club	<input type="checkbox"/> Gaming Hall	<input type="checkbox"/> Convenience Store
 8. Give name and address of owner of premises: OSCAR FARIÑA Warson Development LLC
2 N McNamee Ave 3rd FL, St. Louis, MO 63105
 9. Has a Liquor License been revoked at this location within the past year? NO
 10. State the full name, address and date of birth of the person who you intend to be the Manager or Operator of said establishment, if License is issued: OSCAR J. FARIÑA
15114 Sportsmen Rd Trenton IL 62293 / 12-16-1981
- A. Is such manager a resident of the City of Highland, Illinois? [] YES NO
11. If "yes", how long and address of person _____

12. Is this business located within 100 feet of any church, school, hospital, home for the aged or indigent persons or for veterans, their wives or children or any naval or military station? NO
- A. If answer to the above is "yes", is your place of business a hotel offering restaurant service, a regularly organized club, a food shop, or other place where the sale of liquor is not the principal business carried on? _____
- B. If answer to (A) is "yes", on what date was business started? _____
13. Have any manufacturers, importing distributor or distributor directly or indirectly paid or agreed to pay for this license, advanced money, or anything else of value. Except as specifically permitted in the Act, or any credit, (Other than merchandising credit in the ordinary course of business as specifically permitted in the Act), or is such a person directly or indirectly interested in the ownership, conduct or operation of the place of business? NO If answer is "yes", give particulars _____
- _____
- _____

14. Applicant Information: Name OSCAR J FARINA Telephone 618-696-2339

A. Residence Address 15114 SPORTSMAN Rd Trenton IL 62293
NUMBER STREET CITY STATE ZIP CODE

B. Place of Birth: CARACAS, VENEZUELA
NAME OF CITY, COUNTY AND STATE

Date of Birth: 12 - 16 - 1981
Month Day Year

C. Are you a citizen of the United States? YES If a naturalized citizen, time and place of naturalization? _____

D. Have you ever been convicted of a felony or otherwise disqualified to receive the license applied for by reason of any matter or thing contained in the Illinois Liquor Control Act or the Municipal Liquor Code? [] YES [X] NO If "yes", name court of conviction _____

E. Have you ever made application for a liquor license for any other premises? YES
 Date: 2019/2016 State disposition of application: IL

Give address: 823 Lincoln Hwy, Fairview Heights, IL, 62208
813 Seibert Rd, Scott AFB, IL 62225

F. Are you or is any other person, directly or indirectly interested in your place of business, a public official as defined in Sec 2 (14) Art VI of the Illinois Liquor Control Act? NO If so, office held? _____

G. Has any license previously issued to you by any State or local authorities been SUSPENDED? NO Date: _____

If so, state reasons therefor: _____

Where: _____
CITY COUNTY STATE

H. Has any license previously issued to you by any State or local authorities been REVOKED? NO Date: _____

If so, state reasons therefor: _____

Where: _____
CITY COUNTY STATE

I. Will you comply with the Local Liquor Code and Regulations in connection therewith? yes

15. Co-Applicant information: Name _____

A. Residence Address _____
NUMBER STREET CITY STATE ZIP CODE

B. Place of Birth: _____
NAME OF CITY, COUNTY AND STATE

Date of Birth: _____
Month Day Year

C. Are you a citizen of the United States? _____ If a naturalized citizen, time and place of naturalization? _____

D. Have you ever been convicted of a felony or otherwise disqualified to receive the license applied for by reason of any matter or thing contained in the Illinois Liquor Control Act or the Municipal Liquor Code? [] YES [] NO If "yes", name court of conviction _____

E. Have you ever made application for a liquor license for any other premises? _____

Date: _____ State deposition of application: _____

Give address: _____

F. Are you or is any other person, directly or indirectly interested in your place of business, a public official as defined in Sec 2 (14) Art VI of the Illinois Liquor Control Act? _____ If so, office held? _____

G. Has any license previously issued to you by any State or local authorities been SUSPENDED? _____ Date: _____

If so, state reasons therefor: _____

Where: _____

CITY

COUNTY

STATE

H. Has any license previously issued to you by any State or local authorities been REVOKED? _____ Date: _____

If so, state reasons therefor: _____

Where: _____

CITY

COUNTY

STATE

I. Will you comply with the Local Liquor Code and Regulations in connection therewith? _____

16. State the Names, Home addresses and DOB of all officers and directors of said Corporation:

Name (Last,First,MI)

Home Address (Street, City, State, Zip)

Date of Birth

17. If a majority interest in the stock of the Corporation is owned by one person, or his nominees, state the name and address of such person: _____

18. State the location and description of the premises or place of business which is to be operated under this license: (Attach a detailed diagram of property noting exits, entrances, location of bar, coolers and specific areas where retail liquor may be sold and consumed including and outside areas.)

Street Address: 1014 Laurel St. Highland IL 62249

Owner of Property: WARSON DEVELOPMENT LLC
Last First MI

Address: 2 N Meramee Ave 3rd FL, ST Louis MO 63105
Street/ PO Box City State Zip

Lease from: Month July Day 1 Year 2023 TO
Month July Day 1 Year 2028

(Attach copy of lease to this application)

19. As to any officer, the proposed Manager, or any Director of the Corporation, or a Stockholder owning more than five percent (5%) in the aggregate of the stock in said Corporation, state as follows: Have any of the above ever made application for similar license at a different premises?

Yes

A. If yes, the disposition and date of said application _____

B. State whether any of the above had a previous license revoked by the State, United States Government, or any political subdivision or city? NO

C. If yes, the reasons therefor _____

20. List Name, Addresses and Phone Numbers of five (5) references:

Tim O'Donnell	Highland, IL	(618) 660-8875
Name	Address	Phone

Simon Henao	Syracuse, NY	(618) 434-6029
Name	Address	Phone

David Schlafly	St. Louis, MO	(314) 941-0188
Name	Address	Phone

David Anthony	O'Fallon, IL	(618) 791-5619
Name	Address	Phone

Breck Nelson	Greenville, IL	(309) 357-2613
Name	Address	Phone

**AFFIDAVIT
(PLEASE READ CAREFULLY BEFORE SIGNING)**

I (We) do solemnly swear (or affirm) that the statements given above are true and correct to the best of my (our) knowledge and belief; that I (We) will comply with all regulations of Federal, State and Local Liquor Control Laws; that a copy of an ordinance governing the sale at retail of alcoholic liquors and beverages in this municipality has been furnished to me (us); that I (We) understand the same, and agree to comply with all the provisions set forth therein.

I (We) agree to submit a copy of the State of Illinois Retail Dealers License when received. I shall attach to this application a financial statement listing all assets and liabilities of all owners. I shall attach certificates of proof of coverage for dram shop insurance.

I (We) swear (or affirm) that I (We) will not violate any of the laws of the State of Illinois or of the United States of America in the conduct of the place of business described herein and that the statements contained in this application are true and correct and are made for the purpose of inducing the City of Highland, Illinois to issue the license herein applied for

SUBSCRIBED AND SWORN TO BEFORE ME THIS 24 DAY OF JANUARY, A.D., 2024

Sarah Sloan

Notary Public

(SEAL)



APPLICANT(S) SIGNATURE(S):

[Signature]

CLERK

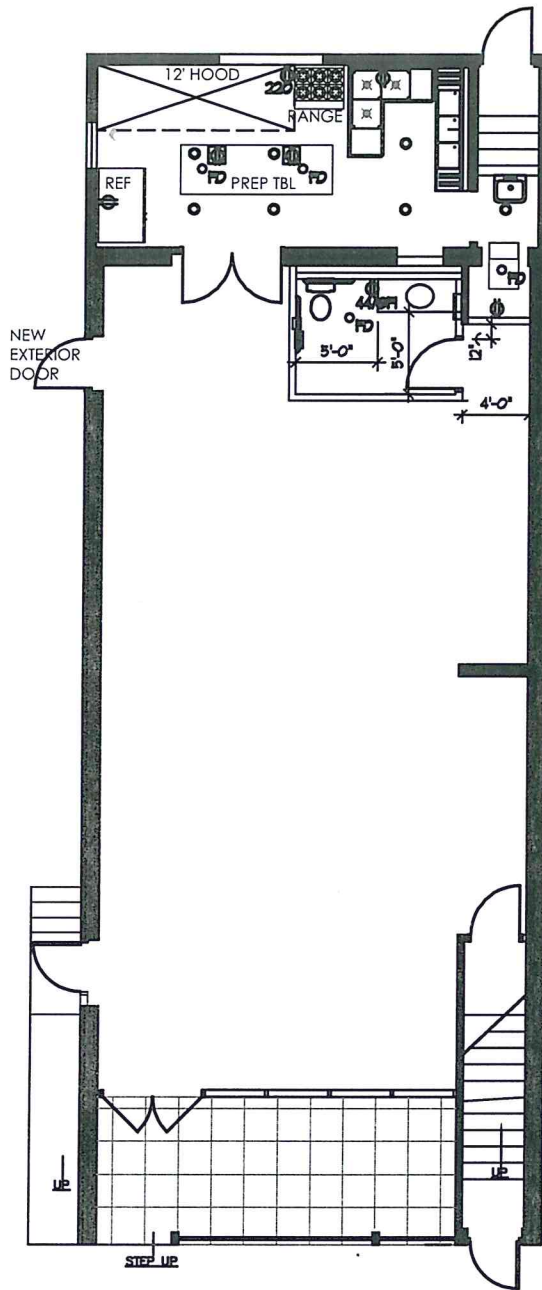

LEGEND

- 3 COMP SINK BY TENANT
PROVIDE WATER SUPPLY
AND DRAIN
- ICE MAKER BY TENANT
PROVIDE WATER LINE AND DRAIN
- PROVIDE CAN LIGHT
- PROVIDE ELECTRICAL RECEPTACLE (110 EXCEPT
WHERE 220 IS NOTED)
- FLOOR DRAIN
- CEILING MTD 110 RECEPTACLE

NOTES

ALL EQUIPMENT PROVIDED AND INSTALLED BY
TENANT

SCHLAFLY
CORPORATION

Oscar
1014 Laurel St
Highland, Illinois

NOT TO SCALE
5-27-2023

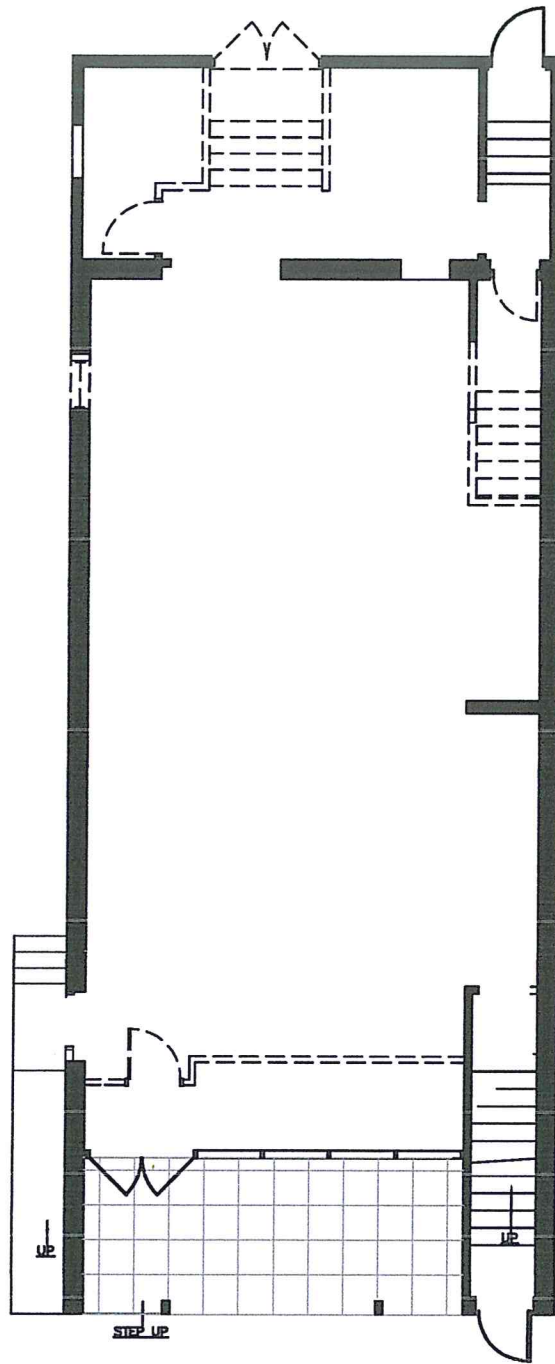

Demolition



SCHLAFLY
CORPORATION

Oscar
1014 Laurel St
Highland, Illinois

NOT TO SCALE

LINEA
DESIGN, INC

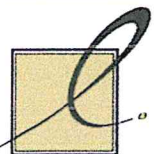

144 W LOCKWOOD AVE SUITE NUMBER 150
WEBSTER GROVES, MISSOURI 63119 314-721-0044

Loyet

ARCHITECTS

Outside Plug for
Sucker

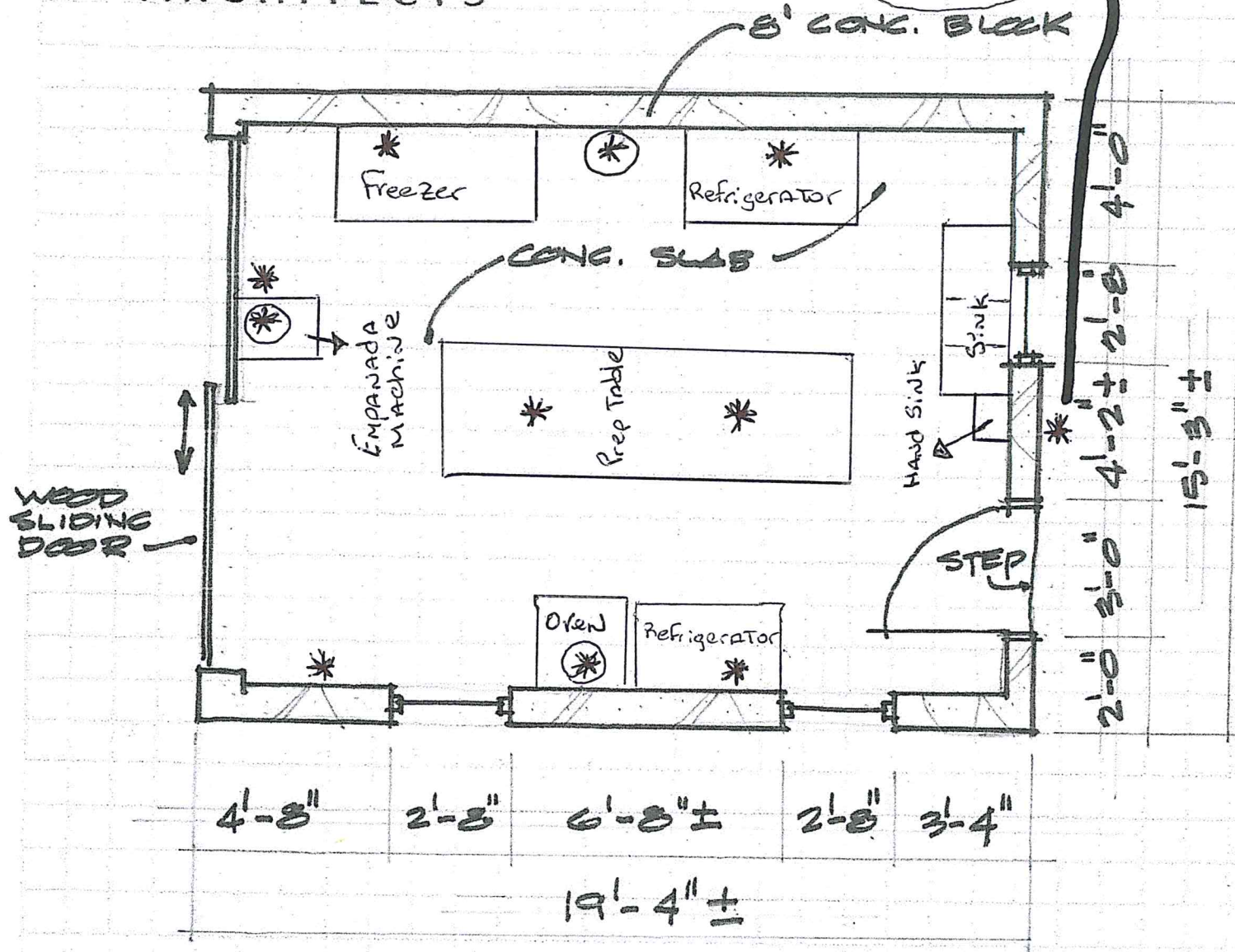

EXISTING GARAGE BUILDING

SCALE

1/4" = 1'-0"

* 110 V outlets

⊛ 220 V outlets

Reference

4 Bar Receptacle

* Receptacle 110V

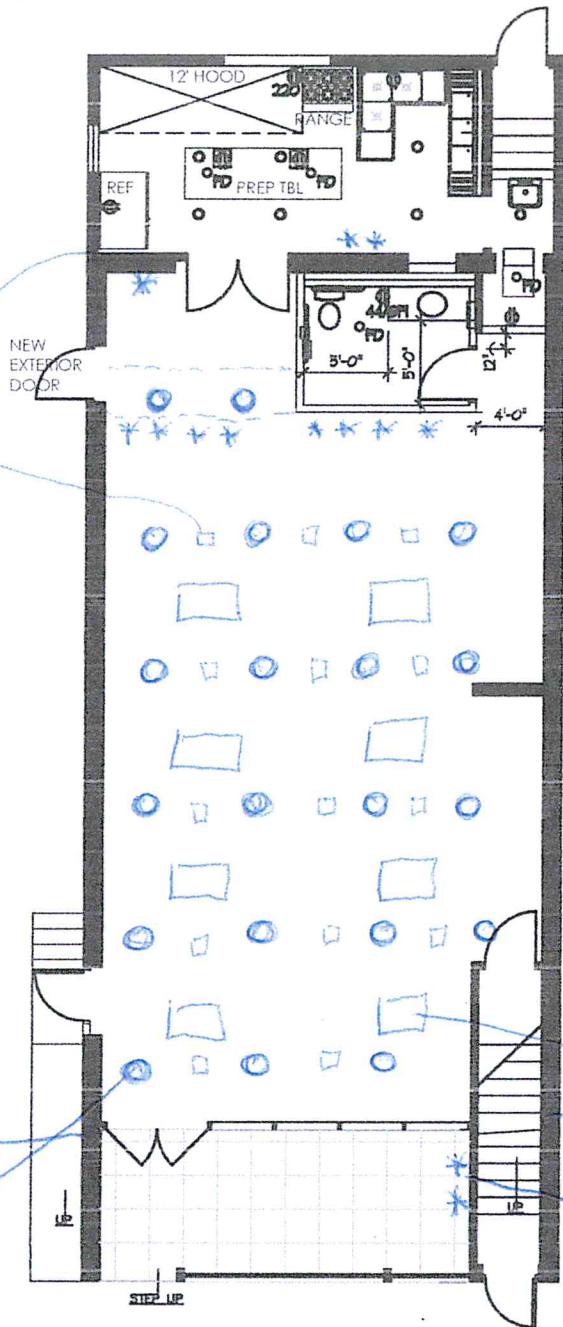

LEGEND

- 3 COMP SINK BY TENANT
PROVIDE WATER SUPPLY AND DRAIN
- ICE MAKER BY TENANT
PROVIDE WATER LINE AND DRAIN
- PROVIDE CAN LIGHT
- PROVIDE ELECTRICAL RECEPTACLE (110 EXCEPT WHERE 220 IS NOTED)
- FLOOR DRAIN
- CEILING MID 110 RECEPTACLE

NOTES

ALL EQUIPMENT PROVIDED AND INSTALLED BY TENANT

JUNCTION BOX For Lamps

110V Receptacle every 10 FT Top of wall AND bottom of wall

110V Receptacle every 10 FT Top of wall bottom of wall

EXTRACTORS (8)

CAN LIGHT

Receptacle Top of wall 10 FT of ground

SCHLAFLY CORPORATION

Oscar
1014 Laurel St
Highland, Illinois

NOT TO SCALE
5-27-2023

RESOLUTION NO. _____

**RESOLUTION ISSUING A “D2” LIQUOR LICENSE TO SDS STORES, INC., D/B/A
EDDIES RISE N’ DINE, PURSUANT TO CHAPTER 6, OF THE CODE OF
ORDINANCES, CITY OF HIGHLAND, ENTITLED ALCOHOLIC LIQUOR**

WHEREAS, the City of Highland, Madison County, Illinois (hereinafter “City”), is a non-home rule municipality duly established, existing and operating in accordance with the provisions of the Illinois Municipal Code (Section 5/1-1-1 et seq. of Chapter 65 of the Illinois Compiled Statutes); and

WHEREAS, City has determined it necessary to provide flexibility and additional authority to the Liquor Commissioner to issue and enforce City liquor licenses; and

WHEREAS, City has authority to define, regulate, issue, and collect fees associated with liquor licenses; and

WHEREAS, City has authority to determine the number, kind, and classification of [liquor] licenses to be issued 235 ILCS 5/4-1; and

WHEREAS, City has the authority to establish [liquor] license fees for the various kinds of licenses to be issued. 235 ILCS 5/4-1; and

WHEREAS, SDS Stores, Inc. d/b/a Eddies Rise N’ Dine (hereinafter “Eddies”) desires to obtain a “D2” restaurant (video gaming) liquor license; and

WHEREAS, Eddies submitted an Application for a Retail Liquor Dealer’s License to City (*see* Application attached hereto as **Exhibit A**); and

WHEREAS, Chapter 6 of the City Code of Ordinances, Alcoholic Liquor, currently defines “Restaurant” as follows:

Restaurant means any public place kept, used, maintained, advertised, and held out to the public as a place where meals are served, and where meals actually are served and regularly served, such space being provided with adequate and sanitary kitchen and dining room equipment and capacity and having employed therein a sufficient number and kind of employees to prepare, cook and serve suitable food for its guests. (See 235 ILCS Sec.5/1-3.23)

and;

WHEREAS, Chapter 6 of the City Code of Ordinances, Alcoholic Liquor, currently defines Class “D2” liquor licenses as follows:

6-2-6 CLASSIFICATION - FEE – LIMITATION.

Every person engaged in the retail sale of alcoholic liquor in the city shall pay an annual license fee. Such licenses shall be divided into the following classes:

(4) Class "D1" and class "D2" licenses: Restaurants. Class "D1" and class "D2" licenses shall authorize the sale of alcoholic liquor of all varieties at retail for consumption on the premises in conjunction with the operation of a restaurant, as well as retail sale of alcoholic liquor in the original package off premises. In addition:

- a. Class "D1" license will not permit the licensee to operate video gaming terminals upon the premises. The annual fee for such license shall be \$500.00.
- b. Class "D2" license may permit the licensee to operate video gaming terminals upon the premises. Class "D2" licenses may permit the licensee to operate video gaming terminals upon the premises, subject to the following conditions:
 1. Any person who displays a video gaming terminal for play or operation by the public shall have, as a prerequisite to receiving any class "D2" license from the city, a valid license issued by the state gaming board for each such video gaming terminal. The cancellation, suspension, or revocation of any such license by the state gaming board shall result in the automatic cancellation, suspension, or revocation of the city's Class "D2" license without refund of any portion of the license fee. An applicant for the class "D2" license shall submit to the city finance director a copy of the license issued by the state gaming board for each video gaming terminal to be played or operated on the licensed premises.

2. Any liquor license issued by the city to any liquor licensee pursuant to this chapter, including but not limited to any licensed fraternal establishment or licensed veterans establishment (as defined in the Video Gaming Act, 230 ILCS 40/5), that displays a video gaming terminal for play or operation within its premises in violation of this subsection shall be immediately revoked.
3. No more than six video gaming terminals may be located on any class "D2" licensee's premises.
4. Every class "D2" licensee shall comply with the provisions of the Video Gaming Act, 230 ILCS 40/1 et seq., as amended, and all rules, regulations, and restrictions imposed by the state gaming board, as amended.
5. The operation of video gaming terminals shall not be permitted during the hours alcoholic liquor sales are prohibited.
6. Video gaming shall be located in a clearly demarcated area that is restricted to persons over 21 years of age.

The annual fee for a class "D2" license shall be \$500.00.

and

WHEREAS, Eddies Application for Retail Liquor Dealer's License (**Exhibit A**) has been approved by the Mayor / Liquor Commissioner; and

WHEREAS, City Council recently passed an Ordinance increasing the number of "D2" liquor licenses available from ten (10) to twelve (12); and

WHEREAS, City has determined there is a "D2" liquor license currently available to be issued to Eddies; and

WHEREAS, City has determined it to be in the best interests of public health, safety, general welfare and economic welfare to issue Eddies a "D2" Liquor License; and

WHEREAS, the Liquor Commissioner reserves the right to ensure all aspects of City Code have been complied with prior to issuance of the "D2" liquor license to Eddies; and

WHEREAS, the City Manager and/or Mayor is authorized and directed to execute any documents necessary to issue a "D2" liquor license to Eddies.

NOW, THEREFORE, BE IT RESOLVED, by the City Council of the City of Highland as follows:

Section 1. The foregoing recitals are incorporated herein as findings of the City Council of the City of Highland, Illinois.

Section 2. City may issue a "D2" liquor license to Eddies.

Section 3. This resolution shall be in full force and effect from and after its passage, approval, and publication in pamphlet form as provided by law.

Passed by the City Council and approved by the Mayor of the City of Highland, Illinois, and deposited and filed in the office of the City Clerk on the _____ day of _____, 2024, the vote being taken by ayes and noes and entered upon the legislative record as follows:

AYES:

NOES:

APPROVED:

Kevin B. Hemann
Mayor
City of Highland
Madison County, Illinois

ATTEST:

Barbara Bellm
City Clerk
City of Highland
Madison County, Illinois

APPLICATION
FOR RETAIL LIQUOR DEALERS LICENSE
CITY OF HIGHLAND

This application properly completed and signed must be filed with the City Clerk and must be accompanied by a remittance in the proper amount, made payable to the City of Highland.

The undersigned individual or partnership hereby makes application for a RETAIL LIQUOR DEALERS LICENSE and submits the following information:

1. Applicant: SDS Stores, Inc.
(GIVE NAME OF INDIVIDUAL OR NAMES OF PARTNERS/CORPORATION ---TYPE OR PRINT CLEARLY)
2. Trade, Partnership or Assumed Name DBA - Eddies Rise N' Dine
3. Give date partnership/corporation was formed under name given on Line 1: 10/18/04
Month Day Year
4. Location of above place of business 12475 IL-143, Highland, IL. 62249
NUMBER STREET CITY STATE ZIP CODE
5. Has your assumed name been filed with the County Clerk?

6. Are alcoholic liquors stored but not sold at any location other than the one given above?
No
If "yes", give location: _____
NUMBER STREET CITY STATE ZIP CODE
7. Check principal kind of business:

<input checked="" type="checkbox"/> Restaurant	<input type="checkbox"/> Tavern
<input type="checkbox"/> Hotel	<input type="checkbox"/> Grocery Store
<input type="checkbox"/> Club	<input type="checkbox"/> Package Store
<input type="checkbox"/> Country Club	<input type="checkbox"/> Gaming Hall
	<input type="checkbox"/> Amusement Place
	<input type="checkbox"/> Department Store
	<input type="checkbox"/> Convenience Store
8. Give name and address of owner of premises: 7680 St Rt 161, Germantown, IL. 62245
9. Has a Liquor License been revoked at this location within the past year? No
10. State the full name, address and date of birth of the person who you intend to be the Manager or Operator of said establishment, if License is issued: Don Schomaker, 8/9/56 (same as #8)

A. Is such manager a resident of the City of Highland, Illinois? YES NO

11. If "yes", how long and address of person _____

12. Is this business located within 100 feet of any church, school, hospital, home for the aged or indigent persons or for veterans, their wives or children or any naval or military station? No

A. If answer to the above is "yes", is your place of business a hotel offering restaurant service, a regularly organized club, a food shop, or other place where the sale of liquor is not the principal business carried on? _____

B. If answer to (A) is "yes", on what date was business started? _____

13. Have any manufacturers, importing distributor or distributor directly or indirectly paid or agreed to pay for this license, advanced money, or anything else of value. Except as specifically permitted in the Act, or any credit, (Other than merchandising credit in the ordinary course of business as specifically permitted in the Act), or is such a person directly or indirectly interested in the ownership, conduct or operation of the place of business? No If answer is "yes", give particulars _____

14. Applicant Information: Name Don Schomaker

A. Residence Address 7680 State Rt 161, Germantown, IL. 62245
NUMBER STREET CITY STATE ZIP CODE

B. Place of Birth: Breese, Clinton County, IL.
NAME OF CITY, COUNTY AND STATE

Date of Birth: 8/9/56
Month Day Year

C. Are you a citizen of the United States? Yes If a naturalized citizen, time and place of naturalization? _____

D. Have you ever been convicted of a felony or otherwise disqualified to receive the license applied for by reason of any matter or thing contained in the Illinois Liquor Control Act or the Municipal Liquor Code? [] YES [] NO If "yes", name court of conviction No

E. Have you ever made application for a liquor license for any other premises? Yes

Date: Jan, 2020 State disposition of application: IL.

Give address: Applebee's 13975 Progress Drive, Breese IL., 62230

F. Are you or is any other person, directly or indirectly interested in your place of business, a public official as defined in Sec 2 (14) Art VI of the Illinois Liquor Control Act? No If so, office held? _____

G. Has any license previously issued to you by any State or local authorities been SUSPENDED? No Date: _____

If so, state reasons therefor: _____

Where: _____
CITY COUNTY STATE

H. Has any license previously issued to you by any State or local authorities been REVOKED? No Date: _____

If so, state reasons therefor: _____

Where: _____
CITY COUNTY STATE

I. Will you comply with the Local Liquor Code and Regulations in connection therewith? Yes

15. Co-Applicant information: Name _____

A. Residence Address _____
NUMBER STREET CITY STATE ZIP CODE

B. Place of Birth: _____
NAME OF CITY, COUNTY AND STATE

Date of Birth: _____
Month Day Year

C. Are you a citizen of the United States? _____ If a naturalized citizen, time and place of naturalization? _____

D. Have you ever been convicted of a felony or otherwise disqualified to receive the license applied for by reason of any matter or thing contained in the Illinois Liquor Control Act or the Municipal Liquor Code? [] YES [] NO If "yes", name court of conviction _____

E. Have you ever made application for a liquor license for any other premises? _____

Date: _____ State deposition of application: _____

Give address: _____

F. Are you or is any other person, directly or indirectly interested in your place of business, a public official as defined in Sec 2 (14) Art VI of the Illinois Liquor Control Act? _____ If so, office held? _____

G. Has any license previously issued to you by any State or local authorities been SUSPENDED? _____ Date: _____

If so, state reasons therefor: _____

Where: _____

CITY COUNTY STATE

H. Has any license previously issued to you by any State or local authorities been REVOKED? _____ Date: _____

If so, state reasons therefor: _____

Where: _____

CITY COUNTY STATE

I. Will you comply with the Local Liquor Code and Regulations in connection therewith? _____

16. State the Names, Home addresses and DOB of all officers and directors of said Corporation:

Name (Last,First,MI) Home Address (Street, City, State, Zip) Date of Birth

Don Schomaker 7680 St Rt 161, Germantown IL, 62244 8/9/56

17. If a majority interest in the stock of the Corporation is owned by one person, or his nominees, state the name and address of such person: Don Schomaker

18. State the location and description of the premises or place of business which is to be operated under this license: (Attach a detailed diagram of property noting exits, entrances, location of bar, coolers and specific areas where retail liquor may be sold and consumed including and outside areas.)
Street Address: 12475 IL-143, Highland, IL. 62293

Owner of Property: Schomaker Don F.
Last First MI

Address: 7680 St Rt 161 Germantown, IL 62245
Street/ PO Box City State Zip

Lease from: Month We own it. Day _____ Year _____ TO

Month No Lease Day _____ Year _____

(Attach copy of lease to this application)

19. As to any officer, the proposed Manager, or any Director of the Corporation, or a Stockholder owning more than five percent (5%) in the aggregate of the stock in said Corporation, state as follows: Have any of the above ever made application for similar license at a different premises?

A. If yes, the disposition and date of said application No

B. State whether any of the above had a previous license revoked by the State, United States Government, or any political subdivision or city? _____

C. If yes, the reasons therefor _____

20. List Name, Addresses and Phone Numbers of five (5) references:

MJ Kellner Springfield IL 217-483-1700

Name	Address	Phone
------	---------	-------

Southern Wine,	Mt. Vernon, IL.	800-776-0180
----------------	-----------------	--------------

Name	Address	Phone
------	---------	-------

Breese Journal,	Breese IL.	618-526-7211
-----------------	------------	--------------

Name	Address	Phone
------	---------	-------

Cick Fritz,	Belleville IL.	618-420-0522
-------------	----------------	--------------

Name	Address	Phone
------	---------	-------

Bradford Bank	Highland IL.	618-664-2200
---------------	--------------	--------------

Name	Address	Phone
------	---------	-------

1st Federal Savings,	Mascoutah IL	618-5662343
----------------------	--------------	-------------

AFFIDAVIT
(PLEASE READ CAREFULLY BEFORE SIGNING)

I (We) do solemnly swear (or affirm) that the statements given above are true and correct to the best of my (our) knowledge and belief; that I (We) will comply with all regulations of Federal, State and Local Liquor Control Laws; that a copy of an ordinance governing the sale at retail of alcoholic liquors and beverages in this municipality has been furnished to me (us); that I (We) understand the same, and agree to comply with all the provisions set forth therein.

I (We) agree to submit a copy of the State of Illinois Retail Dealers License when received. I shall attach to this application a financial statement listing all assets and liabilities of all owners. I shall attach certificates of proof of coverage for dram shop insurance.

I (We) swear (or affirm) that I (We) will not violate any of the laws of the State of Illinois or of the United States of America in the conduct of the place of business described herein and that the statements contained in this application are true and correct and are made for the purpose of inducing the City of Highland, Illinois to issue the license herein applied for

SUBSCRIBED AND SWORN TO BEFORE ME THIS 17 DAY OF Jan, A.D., 2024



Kelsey Krump
Notary Public

(SEAL)

APPLICANT (S):

[Signature]









RESOLUTION NO. _____

RESOLUTION ISSUING A “D2” LIQUOR LICENSE TO KORTE MEAT PROCESSING, INC., PURSUANT TO CHAPTER 6, OF THE CODE OF ORDINANCES, CITY OF HIGHLAND, ENTITLED ALCOHOLIC LIQUOR

WHEREAS, the City of Highland, Madison County, Illinois (hereinafter “City”), is a non-home rule municipality duly established, existing and operating in accordance with the provisions of the Illinois Municipal Code (Section 5/1-1-1 et seq. of Chapter 65 of the Illinois Compiled Statutes); and

WHEREAS, City has determined it necessary to provide flexibility and additional authority to the Liquor Commissioner to issue and enforce City liquor licenses; and

WHEREAS, City has authority to define, regulate, issue, and collect fees associated with liquor licenses; and

WHEREAS, City has authority to determine the number, kind, and classification of [liquor] licenses to be issued 235 ILCS 5/4-1; and

WHEREAS, City has the authority to establish [liquor] license fees for the various kinds of licenses to be issued. 235 ILCS 5/4-1; and

WHEREAS, Korte Meat Processing, Inc. (hereinafter “Korte”) desires to obtain a “D2” restaurant (video gaming) liquor license; and

WHEREAS, Korte submitted an Application for a Retail Liquor Dealer’s License to City (*see* Application attached hereto as **Exhibit A**); and

WHEREAS, Chapter 6 of the City Code of Ordinances, Alcoholic Liquor, currently defines “Restaurant” as follows:

Restaurant means any public place kept, used, maintained, advertised, and held out to the public as a place where meals are served, and where meals actually are served and regularly served, such space being provided with adequate and sanitary kitchen and dining room equipment and capacity and having employed therein a sufficient number and kind of employees to prepare, cook and serve suitable food for its guests. (See 235 ILCS Sec.5/1-3.23)

and;

WHEREAS, Chapter 6 of the City Code of Ordinances, Alcoholic Liquor, currently defines Class “D2” liquor licenses as follows:

6-2-6 CLASSIFICATION - FEE – LIMITATION.

Every person engaged in the retail sale of alcoholic liquor in the city shall pay an annual license fee. Such licenses shall be divided into the following classes:

(4) Class "D1" and class "D2" licenses: Restaurants. Class "D1" and class "D2" licenses shall authorize the sale of alcoholic liquor of all varieties at retail for consumption on the premises in conjunction with the operation of a restaurant, as well as retail sale of alcoholic liquor in the original package off premises. In addition:

- a. Class "D1" license will not permit the licensee to operate video gaming terminals upon the premises. The annual fee for such license shall be \$500.00.
- b. Class "D2" license may permit the licensee to operate video gaming terminals upon the premises. Class "D2" licenses may permit the licensee to operate video gaming terminals upon the premises, subject to the following conditions:
 1. Any person who displays a video gaming terminal for play or operation by the public shall have, as a prerequisite to receiving any class "D2" license from the city, a valid license issued by the state gaming board for each such video gaming terminal. The cancellation, suspension, or revocation of any such license by the state gaming board shall result in the automatic cancellation, suspension, or revocation of the city's Class "D2" license without refund of any portion of the license fee. An applicant for the class "D2" license shall submit to the city finance director a copy of the license issued by the state gaming board for each video gaming terminal to be played or operated on the licensed premises.

2. Any liquor license issued by the city to any liquor licensee pursuant to this chapter, including but not limited to any licensed fraternal establishment or licensed veterans establishment (as defined in the Video Gaming Act, 230 ILCS 40/5), that displays a video gaming terminal for play or operation within its premises in violation of this subsection shall be immediately revoked.
3. No more than six video gaming terminals may be located on any class "D2" licensee's premises.
4. Every class "D2" licensee shall comply with the provisions of the Video Gaming Act, 230 ILCS 40/1 et seq., as amended, and all rules, regulations, and restrictions imposed by the state gaming board, as amended.
5. The operation of video gaming terminals shall not be permitted during the hours alcoholic liquor sales are prohibited.
6. Video gaming shall be located in a clearly demarcated area that is restricted to persons over 21 years of age.

The annual fee for a class "D2" license shall be \$500.00.

and

WHEREAS, Korte's Application for Retail Liquor Dealer's License (**Exhibit A**) has been approved by the Mayor / Liquor Commissioner; and

WHEREAS, City Council recently passed an Ordinance increasing the number of "D2" liquor licenses available from ten (10) to twelve (12); and

WHEREAS, City has determined there is a "D2" liquor license currently available to be issued to Korte; and

WHEREAS, City has determined it to be in the best interests of public health, safety, general welfare and economic welfare to issue Korte a "D2" Liquor License; and

WHEREAS, the Liquor Commissioner reserves the right to ensure all aspects of City Code have been complied with prior to issuance of the "D2" liquor license to Korte; and

WHEREAS, the City Manager and/or Mayor is authorized and directed to execute any documents necessary to issue a "D2" liquor license to Korte.

NOW, THEREFORE, BE IT RESOLVED, by the City Council of the City of Highland as follows:

Section 1. The foregoing recitals are incorporated herein as findings of the City Council of the City of Highland, Illinois.

Section 2. City may issue a "D2" liquor license to Korte.

Section 3. This resolution shall be in full force and effect from and after its passage, approval, and publication in pamphlet form as provided by law.

Passed by the City Council and approved by the Mayor of the City of Highland, Illinois, and deposited and filed in the office of the City Clerk on the _____ day of _____, 2024, the vote being taken by ayes and noes and entered upon the legislative record as follows:

AYES:

NOES:

APPROVED:

Kevin B. Hemann
Mayor
City of Highland
Madison County, Illinois

ATTEST:

Barbara Bellm
City Clerk
City of Highland
Madison County, Illinois

APPLICATION
FOR RETAIL LIQUOR DEALERS LICENSE
CITY OF HIGHLAND

This application properly completed and signed must be filed with the City Clerk and must be accompanied by a remittance in the proper amount, made payable to the City of Highland.

The undersigned individual or partnership hereby makes application for a RETAIL LIQUOR DEALERS LICENSE and submits the following information:

1. Applicant: Amy Koerckenmeier Korte Meat Processing Inc
(GIVE NAME OF INDIVIDUAL OR NAMES OF PARTNERS/CORPORATION ---TYPE OR PRINT CLEARLY)

2. Trade, Partnership or Assumed Name Korte Meat Processing Inc

3. Give date partnership/corporation was formed under name given on Line 1: _____ 1968

4. Location of above place of business 915 Hemlock Highland IL 62249
NUMBER STREET CITY STATE ZIP CODE

5. Has your assumed name been filed with the County Clerk?
yes

6. Are alcoholic liquors stored but not sold at any location other than the one given above?
no

If "yes", give location: _____
NUMBER STREET CITY STATE ZIP CODE

7. Check principal kind of business:

- | | | |
|---|-------------------------------------|---|
| <input checked="" type="radio"/> Restaurant | <input type="radio"/> Tavern | |
| <input type="radio"/> Hotel | <input type="radio"/> Grocery Store | <input type="radio"/> Amusement Place |
| <input type="radio"/> Club | <input type="radio"/> Package Store | <input type="radio"/> Department Store |
| <input type="radio"/> Country Club | <input type="radio"/> Gaming Hall | <input type="radio"/> Convenience Store |

8. Give name and address of owner of premises: Amy Koerckenmeier 13491 Wildlife Trail
Highland IL 62249

9. Has a Liquor License been revoked at this location within the past year? no

10. State the full name, address and date of birth of the person who you intend to be the Manager or Operator of said establishment, if License is issued: ~~no~~ Amy Koerckenmeier

1-20-1983 13491 Wildlife Trail

A. Is such manager a resident of the City of Highland, Illinois? YES NO

11. If "yes", how long and address of person 40 years 13491 Wildlife Trail

12. Is this business located within 100 feet of any church, school, hospital, home for the aged or indigent persons or for veterans, their wives or children or any naval or military station? NO

A. If answer to the above is "yes", is your place of business a hotel offering restaurant service, a regularly organized club, a food shop, or other place where the sale of liquor is not the principal business carried on? _____

B. If answer to (A) is "yes", on what date was business started? _____

13. Have any manufacturers, importing distributor or distributor directly or indirectly paid or agreed to pay for this license, advanced money, or anything else of value. Except as specifically permitted in the Act, or any credit, (Other than merchandising credit in the ordinary course of business as specifically permitted in the Act), or is such a person directly or indirectly interested in the ownership, conduct or operation of the place of business? NO If answer is "yes", give particulars _____

14. Applicant Information: Name Amy Koerkenmeier Telephone 618 779 7652

A. Residence Address 13491 Wildlife Trail Highland IL 62249
NUMBER STREET CITY STATE ZIP CODE

B. Place of Birth: Breese Clinton IL
NAME OF CITY, COUNTY AND STATE

Date of Birth: Jan. 20 1983
Month Day Year

C. Are you a citizen of the United States? Yes If a naturalized citizen, time and place of naturalization? Breese Hospital

D. Have you ever been convicted of a felony or otherwise disqualified to receive the license applied for by reason of any matter or thing contained in the Illinois Liquor Control Act or the Municipal Liquor Code? YES NO If "yes", name court of conviction _____

E. Have you ever made application for a liquor license for any other premises? NO yes ^{act old} Address

Date: 1-26-26 State disposition of application: Approved

Give address: 810 Deal St Highland IL 62249

F. Are you or is any other person, directly or indirectly interested in your place of business, a public official as defined in Sec 2 (14) Art VI of the Illinois Liquor Control Act? NO yes If so, office held? _____

G. Has any license previously issued to you by any State or local authorities been SUSPENDED? NO Date: _____

If so, state reasons therefor: _____

Where: _____
CITY COUNTY STATE

H. Has any license previously issued to you by any State or local authorities been REVOKED? NO Date: _____

If so, state reasons therefor: _____

Where: _____
CITY COUNTY STATE

I. Will you comply with the Local Liquor Code and Regulations in connection therewith? Yes

15. Co-Applicant information: Name Korte Meab Processing Amy Koerckenmaier

A. Residence Address 13491 Wildlife trail Highland IL 62249
NUMBER STREET CITY STATE ZIP CODE

B. Place of Birth: Breese Madison IL
NAME OF CITY, COUNTY AND STATE

Date of Birth: Jan. 20 1983
Month Day Year

C. Are you a citizen of the United States? Yes If a naturalized citizen, time and place of naturalization? _____

D. Have you ever been convicted of a felony or otherwise disqualified to receive the license applied for by reason of any matter or thing contained in the Illinois Liquor Control Act or the Municipal Liquor Code? YES NO If "yes", name court of conviction NO

E. Have you ever made application for a liquor license for any other premises? Yes

Date: Jan. 26 26 State deposition of application: IL

Give address: 915 Hemlock St Highland IL 62249 ^{New}
810 Deal St Highland IL 62249 Current

F. Are you or is any other person, directly or indirectly interested in your place of business, a public official as defined in Sec 2 (14) Art VI of the Illinois Liquor Control Act? yes no If so, office held? _____

G. Has any license previously issued to you by any State or local authorities been SUSPENDED? no Date: _____

If so, state reasons therefor: _____

Where: _____
CITY COUNTY STATE

H. Has any license previously issued to you by any State or local authorities been REVOKED? no Date: _____

If so, state reasons therefor: _____

Where: _____
CITY COUNTY STATE

I. Will you comply with the Local Liquor Code and Regulations in connection therewith? yes

16. State the Names, Home addresses and DOB of all officers and directors of said Corporation:

<u>Name (Last,First,MI)</u>	<u>Home Address (Street, City, State, Zip)</u>	<u>Date of Birth</u>
Koerbenmeier Army L	13491 Wildlife Trail Highland IL 62249	1-20-83
Korte Kyle D	345 Baden Ave Poahontas IL 62275	1-7-85

17. If a majority interest in the stock of the Corporation is owned by one person, or his nominees, state the name and address of such person: _____

18. State the location and description of the premises or place of business which is to be operated under this license: (Attach a detailed diagram of property noting exits, entrances, location of bar, coolers and specific areas where retail liquor may be sold and consumed including and outside areas.)

Street Address: 915 Hemlock St Highland IL 62249

Owner of Property: Kaerkenmeder Amy L
Last First MI

Address: 915 Hemlock St Highland IL 62249
Street/ PO Box City State Zip

Lease from: Month no Lease Day _____ Year _____ TO
Month _____ Day _____ Year _____

(Attach copy of lease to this application)

19. As to any officer, the proposed Manager, or any Director of the Corporation, or a Stockholder owning more than five percent (5%) in the aggregate of the stock in said Corporation, state as follows: Have any of the above ever made application for similar license at a different premises?

A. If yes, the disposition and date of said application _____

B. State whether any of the above had a previous license revoked by the State, United States Government, or any political subdivision or city? _____

C. If yes, the reasons therefor _____

20. List Name, Addresses and Phone Numbers of five (5) references:

Dave Korte	2825 Final Dr	618 781 5361
Name	Address	Phone
Therese Korte	2825 Final Dr	618 781 5362
Name	Address	Phone
Jim Gutzler	610 Broadway	618 910 1418
Name	Address	Phone
Dan Koerkenmeier	2 Meadowlark Ct	618 654 4378
Name	Address	Phone
Pat Sakel	6 Boyer Ln	618 781 0215
Name	Address	Phone

**AFFIDAVIT
(PLEASE READ CAREFULLY BEFORE SIGNING)**

I (We) do solemnly swear (or affirm) that the statements given above are true and correct to the best of my (our) knowledge and belief; that I (We) will comply with all regulations of Federal, State and Local Liquor Control Laws; that a copy of an ordinance governing the sale at retail of alcoholic liquors and beverages in this municipality has been furnished to me (us); that I (We) understand the same, and agree to comply with all the provisions set forth therein.

I (We) agree to submit a copy of the State of Illinois Retail Dealers License when received. I shall attach to this application a financial statement listing all assets and liabilities of all owners. I shall attach certificates of proof of coverage for dram shop insurance.

I (We) swear (or affirm) that I (We) will not violate any of the laws of the State of Illinois or of the United States of America in the conduct of the place of business described herein and that the statements contained in this application are true and correct and are made for the purpose of inducing the City of Highland, Illinois to issue the license herein applied for

SUBSCRIBED AND SWORN TO BEFORE ME THIS 29 DAY OF Jan., A.D., 2024

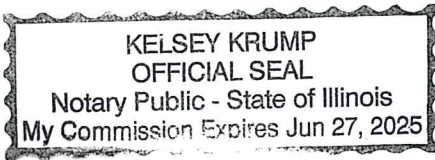

Kelsey Krump
Notary Public

(SEAL)

APPLICANT(S) SIGNATURE(S):

[Handwritten Signature]

CLERK

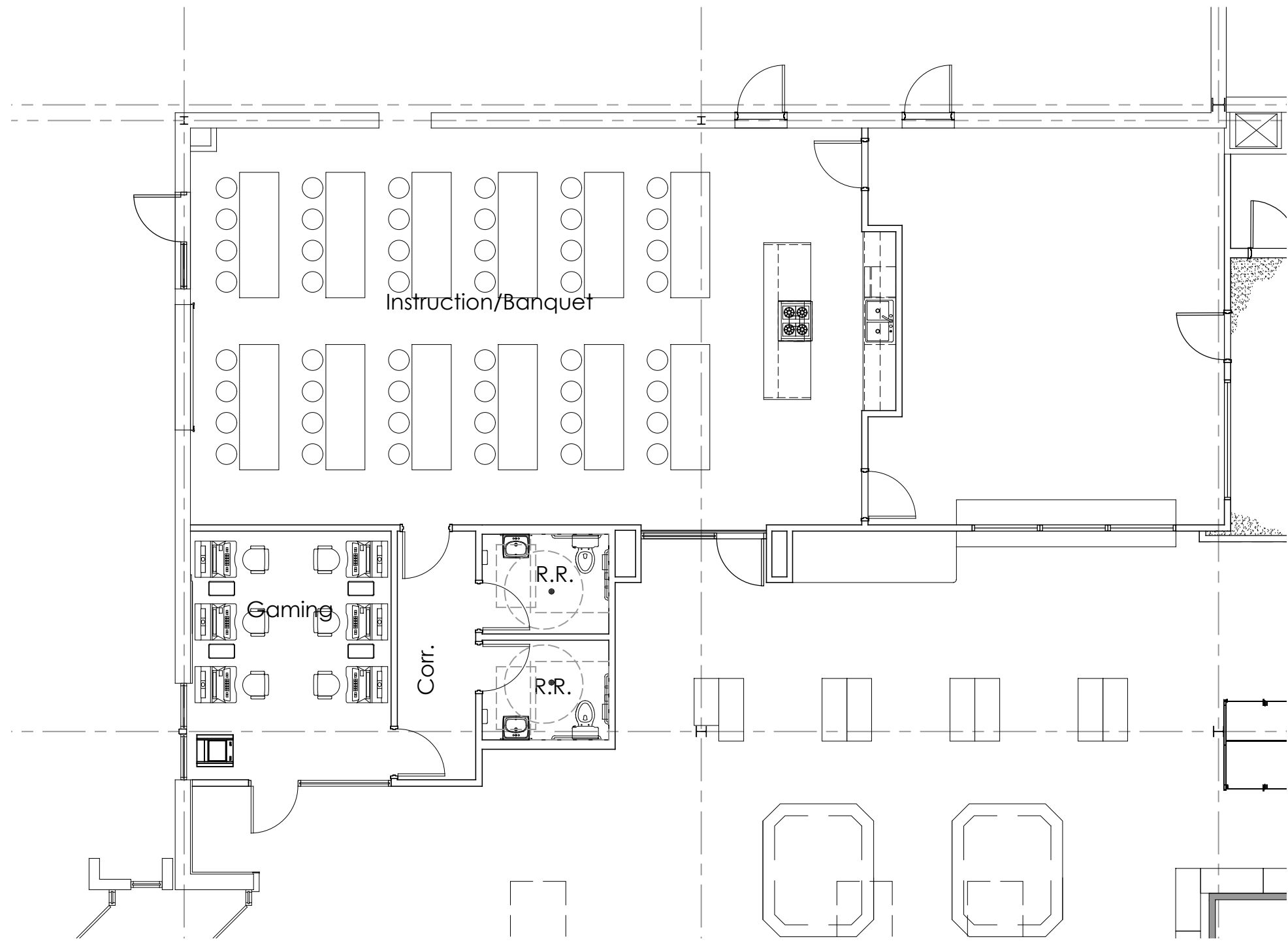



Jackpot
Spot!

3777

Banquet

Menu board with items like TACOS and DRINKS



Inspired
Spot!

Banquet

chen

Order

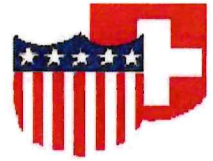

Check No.	Vendor/Employee	Transaction Description	Date	Amount
Fund: 101 Electric Fund				
Department: 000 Balance Sheet Accounts				
14902	JOSEPH DICKENS	Refund Check 021964-000	01/30/2024	2.76
14903	KEELY GRUENENFELDER	Refund Check 023380-000	01/30/2024	15.41
14904	DAMIAN PATCHIN	Refund Check 023615-000	01/30/2024	108.99
Total for Department: 0+D20:D5500 Balance Sheet				127.16
Total for Fund:101 Electric Fund				127.16
Fund: 201 Water Fund				
Department: 000 Balance Sheet Accounts				
14905	RICH ZEIDLIK	Refund Check 008295-000	01/30/2024	227.73
Total for Department: 000 Balance Sheet Accounts				227.73
Total for Fund:201 Water Fund				227.73
Fund: 301 Sewer Fund				
Department: 000 Balance Sheet Accounts				
14905	RICH ZEIDLIK	Refund Check 008295-000	01/30/2024	203.30
Total for Department: 000 Balance Sheet Accounts				203.30
Total for Fund:301 Sewer Fund				203.30
Fund: 713 Solid Waste Fund				
Department: 000 Balance Sheet Accounts				
14902	JOSEPH DICKENS	Refund Check 021964-000	01/30/2024	1.06
14903	KEELY GRUENENFELDER	Refund Check 023380-000	01/30/2024	4.17
Total for Department: 000 Balance Sheet Accounts				5.23
Total for Fund:713 Solid Waste Fund				5.23
Grand Total				563.42

Accepted by City Council February 05, 2024

Mayor: _____

Clerk: _____



CHECK #	VENDOR NAME	INVOICE DESCRIPTION	DEPARTMENT	CHECK/PAYMENT DATE	GROSS AMOUNT
484	APEX HOLDINGS LLC	JOB INCENTIVE PROGRAM	007	01/26/2024	40,625.00
528	FURNITURE REWARDS LLC	2024 SALES TAX INCENTIVE	007	01/26/2024	3,911.30
558	Mastercard	ZOOM.US 01/08/24-02/07/24	007	01/26/2024	15.99
558	Mastercard	JIMMY JOHNS - IDC MEETING 01/03/24	007	01/26/2024	86.24
				TOTAL	44,638.53
483	ALLIED WASTE TRANSPORTATION INC	KRC RECYCLING SERVICES 12/01/23-12/31/23	009	01/26/2024	15.00
487	City Utilities	KRC- UTILITIES	009	01/26/2024	264.53
489	HENRICKSEN & COMPANY INC	KRC NEW LOBBY/MEETING ROOM CHAIRS AND TABLES	009	01/26/2024	8,204.83
489	HENRICKSEN & COMPANY INC	KRC NEW FURNITURE AND INSTALL (TABLES)	009	01/26/2024	3,496.76
497	AMAZON CAPITAL SERVICES	1 QTY CONGO SET OF 4 SWING HANGERS	009	01/26/2024	32.95
545	BETTER NEWSPAPER INC	#10 REG ENVELOPES , #10 WINDOW EVVELOPES	009	01/26/2024	839.30
558	Mastercard	STIFEL THEATRE - YAH GOLDEN GIRLS	009	01/26/2024	352.80
558	Mastercard	WORKBOOTS.COM - RYAN HUMMERT	009	01/26/2024	117.14
558	Mastercard	AMERICAN RED CROSS - LTS FACILITY FEE	009	01/26/2024	300.00
558	Mastercard	2024 MPPA CONFERENCE & EXPO - H HELD	009	01/26/2024	325.00
558	Mastercard	PRECISION LOCKER COMPANY	009	01/26/2024	1,620.04
558	Mastercard	FUN EXPRESS	009	01/26/2024	277.94
558	Mastercard	EREPLACEMENTPARTS.COM	009	01/26/2024	31.16
583	Tech Electronics Inc	2/7/24-5/6-24 PREVENTATIVE MAINT AGREEMENT PERIOD	009	01/26/2024	469.75
585	The Lifeguard Store	LIFEGUARD WHISTLES AND CHEMICAL SUPPLY	009	01/26/2024	119.01
587	TK Elevator Corporation	SERVICE PERIOD 1/12/24-3/31/24	009	01/26/2024	1,407.15
				TOTAL	17,873.36
479	ALLIED WASTE TRANSPORTATION INC	TEMP DUMPSTER SERVICES	011	01/17/2024	4,331.65
480	Southwestern Illinois Council of Mayors	SWICOM MEETING FOR MAYOR AND CITY MANAGER 01/25/24	011	01/17/2024	70.00
481	Highland Community Title LLC	915 2ND ST (THE WUEBBELS FAMILY)	011	01/18/2024	27,967.57
483	ALLIED WASTE TRANSPORTATION INC	RESIDENTIAL TRASH SERVICES 01/01/24-01/31/24	011	01/26/2024	108,687.95
483	ALLIED WASTE TRANSPORTATION INC	TEMP DUMSPTER SERVICES	011	01/26/2024	2,538.78
483	ALLIED WASTE TRANSPORTATION INC	COMMERCIAL TRASH SERVICES 12/01/23-12/31/23	011	01/26/2024	52,566.25
483	ALLIED WASTE TRANSPORTATION INC	COMMERCIAL TRASH SERVICES 12/01/23-12/31/23	011	01/26/2024	4,674.00
487	City Utilities	UTILITES - 1115 BROADWAY	011	01/26/2024	261.47
491	INDOFF INC	DEPOSIT FOR CITY HALL FURNITURE	011	01/26/2024	53,967.76
493	Oates Associates Inc	US RTE 40 & SYCAMORE ST INTERSECTION STUDY& PLANS	011	01/26/2024	2,335.00
497	AMAZON CAPITAL SERVICES	1 QTY 4913 REPLACEMENT PAD BLACK 3 PACK	011	01/26/2024	9.25
497	AMAZON CAPITAL SERVICES	STICKEY NOTES,GLOVES, SHARPIES,HAND SOAP,STENO PAD	011	01/26/2024	252.51
497	AMAZON CAPITAL SERVICES	1 QTY SHARPIE PERMANENT MARKERS	011	01/26/2024	6.94
497	AMAZON CAPITAL SERVICES	2 QTY BLUETOOTH HEADSET	011	01/26/2024	119.98
497	AMAZON CAPITAL SERVICES	1 QTY INTEGRA CORRECTION TAPE	011	01/26/2024	9.98
497	AMAZON CAPITAL SERVICES	12 QTY HEAVY DUTY DISPOSABLE GLOVES	011	01/26/2024	119.88
497	AMAZON CAPITAL SERVICES	1 QTY SHARPIE PERMANENT MARKERS	011	01/26/2024	6.88
505	Belleville News-Democrat	BND SUBSCRIPTION FOR CITY HALL	011	01/26/2024	115.23
515	Constellation NewEnergy Gas Division LLC	GAS SERVICE	011	01/26/2024	1,837.06
519	Drive Social Media	SOCIAL MEDIA MONTHLY SERVICE	011	01/26/2024	2,000.00
533	HIGHLAND AREA CHRISTIAN SERVICE MINISTRY	NOVEMBER 2023 GOOD SAMARITAN	011	01/26/2024	163.14
533	HIGHLAND AREA CHRISTIAN SERVICE MINISTRY	DECEMBER 2023 GOOD SAMARITAN	011	01/26/2024	262.96
534	Highland Communication Services	HCS SERVICES - CITY HALL	011	01/26/2024	597.91
543	JOHN DEERE FINANCIAL	HIGHLAND RURAL KING OPERATING ACCOUNT	011	01/26/2024	2,681.52
546	JULIE Inc	2024 ANNUAL CHARGES FOR JULIE	011	01/26/2024	3,258.45
557	M5 MANAGEMENT GROUP	2023 TAX INCENTIVE REIMBURSEMENT	011	01/26/2024	2,886.54
558	Mastercard	LABOR LAW POSTERS ALL DEPTS	011	01/26/2024	562.10
558	Mastercard	IL MUNICIPAL LEAGUE - C CONRAD	011	01/26/2024	225.00
558	Mastercard	USPS POSTAGE MAIL ERNST FAMILY FARM CK	011	01/26/2024	28.75
560	McKay Auto Parts Inc	1 QTY BATTERY BACKUP GENERATOR CITY HALL/WCC	011	01/26/2024	221.49
568	PONTEM SOFTWARE	CM ONLINE BURIAL SEARCH/ANNUAL SUPPORT MAINTENANCE	011	01/26/2024	2,615.00
570	PRESTIGE BUSINESS EQUIPMENT LLC	#10 WINDOW ENVELOPES, #10 CUSTOM BOTTOM FLAP ENVEL	011	01/26/2024	712.70
571	QUADIANT INC.	POSTAGE MACHINE METER RENTAL 10/01/23-12/31/23	011	01/26/2024	223.82
574	Rotary Club of Highland	1ST QTR DUES/MEALS 07/19/23-09/30/23 CHRIS CONRAD	011	01/26/2024	143.00
574	Rotary Club of Highland	2ND QTR DUES/MEALS 10/01/23-12/31/23 CHRIS CONRAD	011	01/26/2024	116.00
589	TRUTH FREEDOM RECORD	PERFORMANCE 02/03/24 CITY OF HIGHLAND	011	01/26/2024	500.00
591	Verizon Wireless - State	VERIZON WIRELESS CHARGES	011	01/26/2024	4,020.03
599	DENNIS ORSEY	RAMAINING BALANCE DUE THIS QUARTER	011	01/30/2024	389.81
599	DENNIS ORSEY	QUARTERLY RETAINER FOR 01/21/24 THROUGH 04/20/24	011	01/30/2024	1,800.00
600	Mastercard	PADDLE.NET IMAZING UNLIMITED DEVICES	011	02/02/2024	44.99
600	Mastercard	ZOOM.US 12/21/23-01/20/24	011	02/02/2024	219.90
				TOTAL	283,551.25
477	MORROW BROTHERS	2023 FORD VEH#1FTW1P83PKF57753	012	01/16/2024	48,850.00
483	ALLIED WASTE TRANSPORTATION INC	PD RECYCLING SERVICE 12/01/23-12/31/23	012	01/26/2024	45.00
487	City Utilities	UTILITIES - HIGHLAND ROAD COMMUNICATION TOWER	012	01/26/2024	25.00
487	City Utilities	CITY UTILITIES RADIO SHED	012	01/26/2024	25.00
487	City Utilities	CITY UTILITIES P58	012	01/26/2024	180.99
487	City Utilities	CITY UTILITIES WATER FOUNTAIN	012	01/26/2024	10.29
488	GETTY UP 7 INC	FACADE PROGRAM	012	01/26/2024	10,000.00
529	Galls LLC	TACTICAL EAR GADGETS GHOST EAR MOLD & BASE CREW	012	01/26/2024	81.73
553	Leon Uniform Company Inc	LS UNDERVEST SHIRT AND US FLAG BORDER	012	01/26/2024	69.00
553	Leon Uniform Company Inc	SS SHIRT, PANTS, LS SHIRTS, SS UNDER VEST WEGAND	012	01/26/2024	200.24
553	Leon Uniform Company Inc	HORNER-CARGO PANTS, LS SHIRT	012	01/26/2024	171.25
558	Mastercard	SCRIBBLE PROG TO DESIGN MAPS SPECIAL EVENT RUNS	012	01/26/2024	19.00
558	Mastercard	TRACFONE FOR SAFE TEAM	012	01/26/2024	22.50
558	Mastercard	TACTACAM MONTHLY CAMERA FEE	012	01/26/2024	5.00
558	Mastercard	IACP YEARLY MEMBERSHIP	012	01/26/2024	190.00
558	Mastercard	HANDCUFF CASE 2, ZERO 9 CASE FOR TASER	012	01/26/2024	130.97
558	Mastercard	BATON CASE, BODY CAM CASE, CASE TASER, RADIO CASE	012	01/26/2024	297.94
558	Mastercard	UNIFORM EQUIPMENT FOR DUTY BELT	012	01/26/2024	297.94
558	Mastercard	BLOODBORNE AND HAZMAT TRAINING 25 USERS	012	01/26/2024	539.99

558 Mastercard	INTERNATIONAL FEE FOR SCRIBBLEMA	012	01/26/2024	0.17
564 Municipal Electronics Inc	REPAIR STALKER DUAL DSR AMP 40306 AND CERTIFY	012	01/26/2024	214.09
572 QUENCH USA INC	WATER COOLER RENTAL FEE POLICE DEPT	012	01/26/2024	165.00
573 Reding Tire & Battery Inc	CAR 8 OIL CHANGE	012	01/26/2024	43.05
573 Reding Tire & Battery Inc	CAR SRO BATTERY	012	01/26/2024	177.50
573 Reding Tire & Battery Inc	CAR 2 REPLACE ALTERNATOR AIR FILTER & TIRE PATCH	012	01/26/2024	635.69
573 Reding Tire & Battery Inc	CAR 6 WATER PUMP AND OIL CHANGE	012	01/26/2024	524.65
594 Watts Copy Systems Inc.	DETECTIVE COPIER/PRINTER/FAX	012	01/26/2024	39.66
	TOTAL			62,961.65
558 Mastercard	ZOOM.US 12/10/23-01/09/24	013	01/26/2024	15.99
558 Mastercard	DROPPBOX 12/28/23-01/28/24	013	01/26/2024	11.99
558 Mastercard	ALLPAID MADISON COUNTY RECORDER OFFICE	013	01/26/2024	154.43
	TOTAL			182.41
487 City Utilities	UTILITIES - SHED BOAT DOCK	014	01/26/2024	15.00
487 City Utilities	UTILITIES - 184 WOODCREST DR	014	01/26/2024	212.53
487 City Utilities	UTILITIES - BOAT RAMP HYDRANT	014	01/26/2024	10.29
497 AMAZON CAPITAL SERVICES	MOUNTING PLATE,MULTIKEY, NEW FIRE TRUCK UNIT 1515	014	01/26/2024	304.59
497 AMAZON CAPITAL SERVICES	1 QTY DIXON VALVE STORZ MOUNTING PLATE	014	01/26/2024	249.40
497 AMAZON CAPITAL SERVICES	DRILL HOOK WALL MOUNT, WORTHY TOOLS WALL HOOK	014	01/26/2024	131.63
514 Consolidated Fleet Services Inc	FEET OF GROUND LADDERS,HEAT SENSOR,UNIT LADDER	014	01/26/2024	1,783.00
517 DINGES PARTNERS GROUP LLC	ROTARY DISC SAW BLADE BAG FOR NEW TRUCK UNIT 1515	014	01/26/2024	425.11
520 ED M. FELD EQUIPMENT CO. INC.	JAFRIB LDH, 21/2X50FT ARMTEX ATTACK	014	01/26/2024	7,250.10
520 ED M. FELD EQUIPMENT CO. INC.	4 QTY FIRE ARMOR GLOVE, 1 QTY FIRE ARMOR GLOVE	014	01/26/2024	540.00
525 PLUMBERS SUPPLY #215	SUPPLIES FOR NEW FIRE TRUCK UNIT 1515	014	01/26/2024	1,153.62
553 Leon Uniform Company Inc	1 QTY WMNS ENFORCER OXFORD - A SEEGERS	014	01/26/2024	86.00
558 Mastercard	DOMINOS - ACTIVE SHOOTER TRAINING	014	01/26/2024	217.43
558 Mastercard	EL FLANAGANS - FIRE OFFICER TRAINING	014	01/26/2024	92.52
558 Mastercard	WPSG INC PARTS NEW FIRE ENGINE UNIT #1515	014	01/26/2024	346.80
558 Mastercard	LOWES - PARTS NEW FIRE ENGINE UNIT #1515	014	01/26/2024	188.53
559 MCFA DEATH BENEFIT	DEATH BEN ASSES - #1471 R BOXDORFER OF MEADOWBROOK	014	01/26/2024	69.00
559 MCFA DEATH BENEFIT	DEATH BEN ASSES - #1472 HAROLD HAMANN OF HAMEL	014	01/26/2024	69.00
559 MCFA DEATH BENEFIT	DEATH BEN ASSES - #1473 ROBERT KILLEBREW OFE ALTON	014	01/26/2024	69.00
579 SIGNS & DESIGNS BY RONNIE DEIEN LLC	WRAP FOR NEW FIRE TRUCK UNIT 1515	014	01/26/2024	3,187.50
	TOTAL			16,401.05
478 Kohnen Concrete Products Inc.	4 QTY PARKING CURB BLUE	016	01/17/2024	192.00
478 Kohnen Concrete Products Inc.	11 QTY PARKING CURB YELLOW	016	01/17/2024	528.00
478 Kohnen Concrete Products Inc.	12 QTY PARKING CURB YELLOW	016	01/17/2024	550.00
487 City Utilities	SENIOR CENTER- UTILITIES	016	01/26/2024	355.34
487 City Utilities	SPINDLER PARK- UTILITIES	016	01/26/2024	25.00
487 City Utilities	BRAD'S SHED- UTILITIES	016	01/26/2024	45.91
487 City Utilities	GLIK PARK- UTILITIES	016	01/26/2024	262.28
487 City Utilities	GLIK PAVILION- UTILITIES	016	01/26/2024	25.00
487 City Utilities	WCC- UTILITIES	016	01/26/2024	1,891.84
487 City Utilities	WCC- UTILITIES	016	01/26/2024	115.94
487 City Utilities	SQUARE/FOUNTAIN- UTILITIES	016	01/26/2024	897.45
487 City Utilities	PARK RD BATHROOM PAV WATER- UTILITIES	016	01/26/2024	55.91
487 City Utilities	HIGHLAND PARK RD- UTILITIES	016	01/26/2024	25.00
487 City Utilities	SPORTSMAN RD NE BATHROOM- UTILITIES	016	01/26/2024	25.00
487 City Utilities	KRC GARDENS- UTILITIES	016	01/26/2024	25.00
487 City Utilities	BROADWAY- UTILITIES	016	01/26/2024	25.34
487 City Utilities	SE TENNIS COURTS- UTILITIES	016	01/26/2024	25.00
487 City Utilities	VETERANS HONOR PKWY BATHROOMS- UTILITIES	016	01/26/2024	25.00
487 City Utilities	HIGHLAND PARK RD ADA RESTROOM- UTILITIES	016	01/26/2024	25.00
487 City Utilities	MAIN ST BATHROOM- UTILITIES	016	01/26/2024	806.05
502 Aviston Lumber Company	PARKS - PICNIC TABLE MAINT.	016	01/26/2024	237.60
502 Aviston Lumber Company	PARKS - PICNIC TABLE MAINT.	016	01/26/2024	84.06
502 Aviston Lumber Company	PARKS - PICNIC TABLE MAINT.	016	01/26/2024	128.57
502 Aviston Lumber Company	PARKS - PICNIC TABLE MAINT.	016	01/26/2024	210.60
512 City Of Highland	PLUMBING NEW CONST COMM/IND/MULTI FAM	016	01/26/2024	150.00
532 Hediger's Backhoe Inc.	DOG PARK PUMP	016	01/26/2024	600.00
532 Hediger's Backhoe Inc.	DOG PARK PUMP	016	01/26/2024	200.00
550 Kohnen Concrete Products Inc.	MANHOLE MAINT/REPLACEMENT	016	01/26/2024	945.00
566 Northtown Auto & Tractor	BATTERY FOR RAM DUMP TRUCK	016	01/26/2024	355.52
578 Schulte Supply Inc	DOUBLE WALL SOLID DRAINAGE PIPE-PARKS	016	01/26/2024	1,140.00
582 SUMNER ONE INC.	WCC PRINTER MONTHLY BILL	016	01/26/2024	60.00
592 Village Locksmith	GLIK PARK- SCHLAGE KEYPAD ENTRY	016	01/26/2024	427.96
600 Mastercard	GODADDY.COM DOMAIN RENEWAL HIGHLANDILSPORTS.COM	016	02/02/2024	22.17
	TOTAL			10,487.54
487 City Utilities	UTILITIES - S&A	017	01/26/2024	64.74
487 City Utilities	UTILITIES - S & A	017	01/26/2024	644.15
487 City Utilities	UTILITIES - S & A	017	01/26/2024	78.46
493 Oates Associates Inc	2023 STP APPLICATION NFOR SOUTH POPLAR STREET	017	01/26/2024	5,517.50
493 Oates Associates Inc	6TH STREET - RECONSTRUCT. PH 2 & 3	017	01/26/2024	13,537.61
502 Aviston Lumber Company	12CDT - 1/2 4X8 CDX TREATED PLYWOOD	017	01/26/2024	164.56
510 Cargill Incorporated	SALT - 104.36 TON, \$78.19 PER TON	017	01/26/2024	8,159.90
513 COMPUSTITCH SCREEN PRINT	1 SHIRT-LOGO EMBROIDERY RYAN H	017	01/26/2024	9.00
516 Curry & Associates Engineers Inc	RECONSTRUCT. OLD HIGHLAND CITY LAKE SPILLWAY	017	01/26/2024	786.48
516 Curry & Associates Engineers Inc	FORCE MAIN GRAVITY SEWER, PUMP STATION @VHP/RTE 40	017	01/26/2024	1,827.00
518 Dr. Wood Trees & Landscape	SECTOR 1 TREE WORK, & REMOVALS, STUMPS REMOVED	017	01/26/2024	5,387.50
521 EJ EQUIPMENT INC.	2 Main Brooms & 5 Gutter Brooms for Street Sw.	017	01/26/2024	1,969.29
535 Highland Optimist Club	GARBAGE BAGS FOR CENTRAL PURCHASING	017	01/26/2024	905.00
558 Mastercard	MUNCIE POWER PRODUCTS	017	01/26/2024	490.04
560 McKay Auto Parts Inc	AIR FILTER, FEMALE COUPLER 1 2 IN	017	01/26/2024	88.04
575 RUSH TRUCK CENTERS OF MISSOURI INC	TRUCK PARTS FOR S&A-BY SCOTT/KELLY-OCT. '23 INV.	017	01/26/2024	1,041.60
575 RUSH TRUCK CENTERS OF MISSOURI INC	TRUCK PARTS FOR S&A-BY SCOTT/KELLY-OCT. '23 INV.	017	01/26/2024	445.00
575 RUSH TRUCK CENTERS OF MISSOURI INC	TRUCK PARTS FOR S&A-BY SCOTT/KELLY-OCT. '23 INV.	017	01/26/2024	77.90
575 RUSH TRUCK CENTERS OF MISSOURI INC	TRUCK PARTS FOR S&A-BY SCOTT/KELLY-OCT. '23 INV.	017	01/26/2024	2,595.00
575 RUSH TRUCK CENTERS OF MISSOURI INC	TRUCK PARTS FOR S&A-BY SCOTT/KELLY-OCT. '23 INV.	017	01/26/2024	2,864.60
576 RYAN HELLMANN	RURAL KING - 3 SHORT SLEEVE T-SHIRTS	017	01/26/2024	60.88
593 Warning Lites of Southern IL. LLC	SQUARE SIGN POSTS	017	01/26/2024	3,905.20
593 Warning Lites of Southern IL. LLC	SWEATSHIRT CLASS 3 LEVEL 3 HOODED - JARED S.-S&A	017	01/26/2024	43.44
	TOTAL			50,662.89

486	CDG ENGINEERS INC	Professional Engineering XCon study.	101	01/26/2024	13,828.80
486	CDG ENGINEERS INC	Professional Engineering XCon study.	101	01/26/2024	3,457.20
487	City Utilities	UTILITIES- PP	101	01/26/2024	123.56
487	City Utilities	UTILITIES- PP	101	01/26/2024	25.00
497	AMAZON CAPITAL SERVICES	1 QTY DURACELL 3V LITH BATTERY	101	01/26/2024	14.99
498	Ameren Illinois	GAS SERVICE	101	01/26/2024	2,267.39
500	ANIXTER INC.	QUOTE # U00742222.00	101	01/26/2024	122.61
506	BEST ONE TIRE & SERVICE OF CLINTON COUNTY	TRUCK 10 TIRES	101	01/26/2024	925.30
511	Cee Kay Supply Inc	RENTAL 300 NITROGEN	101	01/26/2024	11.58
541	Itron Inc	FCS SFTW MAINTENCE,IMADRIIVEYENDPOINTS,SUBCRPTION	101	01/26/2024	6,830.78
542	JANSEN CHEVROLET CO INC	TRUCK 99 INSPECTION	101	01/26/2024	51.00
558	Mastercard	TRAINING FOR LORA TEBBE	101	01/26/2024	249.00
558	Mastercard	TRAINING FOR BILL FRANKE	101	01/26/2024	249.00
558	Mastercard	TRAINING FOR BILL FRANKE	101	01/26/2024	1,695.00
560	McKay Auto Parts Inc	SHOP SUPPLIES	101	01/26/2024	57.45
588	Transworld Systems Inc	DECEMBER COLLECTION AGENCY DUES	101	01/26/2024	12.49
				TOTAL	29,921.15
485	C.T.R CONCRETE & BUILDERS INC.	GARAGE DOORS, LABOR/MATERIALS	102	01/26/2024	12,869.00
487	City Utilities	UTILITIES- PP	102	01/26/2024	15.00
487	City Utilities	UTILITIES- PP	102	01/26/2024	10.29
487	City Utilities	UTILITIES- PP	102	01/26/2024	58.84
487	City Utilities	UTILITIES- PP	102	01/26/2024	35.29
487	City Utilities	UTILITIES- PP	102	01/26/2024	49.86
487	City Utilities	UTILITIES- PP	102	01/26/2024	25.00
526	Ferrelgas	PROPANE REFILL FOR POWER PLANT	102	01/26/2024	205.93
544	Johnstone Supply	ORFICES FOR SHOP HEATERS	102	01/26/2024	109.76
544	Johnstone Supply	THERMOSTAT FOR SHOP HEATER	102	01/26/2024	170.26
558	Mastercard	REFUND FROM BCL	102	01/26/2024	-185.14
558	Mastercard	SHOP ITEMS FOR NEW SHOP	102	01/26/2024	1,439.60
558	Mastercard	HERBICIDE CLASS OPERATORS GENERAL	102	01/26/2024	200.00
558	Mastercard	HERBICIDE CLASS APPLICATORS RIGHT OF WAY	102	01/26/2024	150.00
558	Mastercard	HOME DEPOT	102	01/26/2024	92.16
561	Meyer Electrical & Farm Inc	PLUG ENDS FOR HEATER CORD	102	01/26/2024	283.69
				TOTAL	15,529.54
494	T.R. MILLER MILL CO. INC.	35 QTY REA SD C3 40' POLE ET 1.00	104	01/26/2024	16,857.75
497	AMAZON CAPITAL SERVICES	2 -REPLACEMENTMILWAUKEE 18V BAT, 1-2PK LITH BATTER	104	01/26/2024	225.97
498	Ameren Illinois	GAS CHARGES- ELECTRIC	104	01/26/2024	49.90
500	ANIXTER INC.	Quote # U00739936.00	104	01/26/2024	349.44
506	BEST ONE TIRE & SERVICE OF CLINTON COUNTY	TRUCK 52 TIRE BALANCE & ROTATION	104	01/26/2024	210.00
527	Fletcher Reinhardt Company	SHOP SUPPLIES	104	01/26/2024	2,512.31
527	Fletcher Reinhardt Company	PGMS-4072 GUY WIRE MARKER 8" B PROFILE	104	01/26/2024	526.00
530	GEBKE BROS OUTDOOR PWR EQUIP. INC.	VEHICLE INSPECTIONS #50 GENE'S TRUCK	104	01/26/2024	39.00
530	GEBKE BROS OUTDOOR PWR EQUIP. INC.	VEHICLE INSPECTIONS #222 TREE TRUCK	104	01/26/2024	39.00
558	Mastercard	FILLED 300 NITROGEN	104	01/26/2024	92.26
569	Power Line Supply	SHOP SUPPLIES	104	01/26/2024	170.00
				TOTAL	21,071.63
482	4COM Inc	JANUARY 2024 PROGRAMMING	111	01/17/2024	60,804.77
487	City Utilities	UTILITIES - 192 WOODCREST DR	111	01/26/2024	2,021.39
487	City Utilities	UTILITES - 192 WOODCREST DR OFFICE	111	01/26/2024	307.06
497	AMAZON CAPITAL SERVICES	2 QTY 4N1 BRAIDED MULTI CHARGING CABLE FOR CELL	111	01/26/2024	21.98
497	AMAZON CAPITAL SERVICES	2 QTY USB TYPE C CABLE FAST CHARGING 3 PK	111	01/26/2024	19.98
497	AMAZON CAPITAL SERVICES	3- FIBER OPTICAL SPLITTER, 2- FIBER OPTICALSPLITTE	111	01/26/2024	54.95
497	AMAZON CAPITAL SERVICES	1 QTY RECHARGEABLE BATTERY PACK	111	01/26/2024	14.99
497	AMAZON CAPITAL SERVICES	5 QTY HDMI ADAPTER 2 PKY	111	01/26/2024	44.90
497	AMAZON CAPITAL SERVICES	1 QTY REPLACEMENT BATTERY FOR LETTNER	111	01/26/2024	29.77
497	AMAZON CAPITAL SERVICES	WIRELESS BLUETOOTH EARPIECE, POLYGOM IP PHONE	111	01/26/2024	170.99
497	AMAZON CAPITAL SERVICES	1 QTY LABEL PRINTER, 5 QTY 8 PORT GIGABIT SWITCH	111	01/26/2024	361.69
501	ARELION	ETHERNET VIRTUAL PRIVATE LINE (01/02/24-02/29/24)	111	01/26/2024	4,230.00
501	ARELION	ETHERNET CLJENT PORT 10G (01/02/24-02/29/24)	111	01/26/2024	50.00
503	BALLY SPORTS ST. LOUIS	DECEMBER VIDEO FEE	111	01/26/2024	9,165.66
509	CALIX INC.	CLOUD FOUNDATION SOLUTION AND SUPPORT JAN. 2024	111	01/26/2024	348.58
523	Fastenal	50 QTY 1/4" EPDM COL CLAMP	111	01/26/2024	35.35
539	ILLINOIS TELECOMMUNICATIONS ACCESS CORP.	LOCAL EXCHANGE CARRIER&INTERCONNECTEDVOIP&WIRELESS	111	01/26/2024	14.02
548	KGP Logistics Inc	PREMIER 1 PLEX FACEPLATE	111	01/26/2024	307.68
551	Langhauser Sheet Metal Co	WASHED FILTER ON DEHUMIDIFIER	111	01/26/2024	140.00
565	NEXSTAR BROADCASTING INC.	DECEMBER VIDEO CONTENT FEE - KTVI-FOX	111	01/26/2024	5,701.80
565	NEXSTAR BROADCASTING INC.	DECEMBER VIDEO CONTENT FEE - KPLR-CW	111	01/26/2024	2,112.76
565	NEXSTAR BROADCASTING INC.	DECEMBER VIDEO CONTENT FEE - CN-BASIC	111	01/26/2024	503.88
582	SUMNER ONE INC.	COPIER/LEASE USAGE	111	01/26/2024	151.79
586	TIVO PLATFORM TECHNOLOGIES LLC	NCPT 866.5ACCTS.144 NDVRADDTLUSAGE.467.5 STREAMS	111	01/26/2024	7,775.41
597	Zobrist Signs	ST ROSE ROAD EAST OF HIGHLAND	111	01/26/2024	100.00
598	CALIX INC.	SOLUTION & SUPPORT 12/01/23 TO 12/31/23	111	01/26/2024	336.40
600	Mastercard	DREAMSTIME.COM STOCK PHOTOGRAPHY SUBCRPTION	111	02/02/2024	25.00
600	Mastercard	DYN*DYN.COM	111	02/02/2024	5.00
600	Mastercard	FACEBOOK.COM 11/28/23-12/27/23	111	02/02/2024	319.95
600	Mastercard	FACEBOOK.COM 12/28/23-12/28/23	111	02/02/2024	14.05
600	Mastercard	FACEBOOK.COM 12/28/23-01/03/24	111	02/02/2024	68.75
				TOTAL	95,258.55
487	City Utilities	UTILITIES - WTP	202	01/26/2024	25.00
487	City Utilities	UTILITIES - WTP	202	01/26/2024	25.00
487	City Utilities	UTILITIES - WTP	202	01/26/2024	3,269.68
487	City Utilities	UTILITIES - WTP	202	01/26/2024	38.24
492	KORTE & LUITJOHN CONSTR I	FOR PERIOS 12/31/21 #2 HWTP METERS, ADD RAW VALVE	202	01/26/2024	13,828.63
497	AMAZON CAPITAL SERVICES	1 QTY RPJC 11X14 PICTURE FRAME	202	01/26/2024	12.74
499	American Water Capitol Corporation	WTP - BELLEVILLE LAB TESTS	202	01/26/2024	475.00
504	BARNETT PEST SOLUTIONS	WTP - ONSLAUGHT - Jan.- 2 MAIN, 2 OUT BUILDINGS	202	01/26/2024	130.00
508	Brenntag Mid South Inc	SODIUM HYDROXIDE, CHLORINE	202	01/26/2024	5,845.00
537	Illinois Electric Inc	ANNUAL HOIST INSPECTIONS MARCH 2023-NOV. INV. LATE	202	01/26/2024	1,000.00
538	Illinois Section AWWA	ISAWWA LEADERSHIP SERIES - SESSION# 2 OCT.-GARY P.	202	01/26/2024	40.00
540	INDUSTRIAL MOTOR REPAIR	REPAIR BOOSTER PUMP 4	202	01/26/2024	1,950.29
540	INDUSTRIAL MOTOR REPAIR	HIGH SERVICE PUMP 1 REPAIRS	202	01/26/2024	3,021.07

555 Luby Equipment Services	BOOSTER GENERATOR REPAIR - POWER MOD., BATTERY	202	01/26/2024	2,665.27
			TOTAL	32,325.92
487 City Utilities	UTILITIES - W&S	203	01/26/2024	55.91
487 City Utilities	UTILITIES - W&S	203	01/26/2024	27.00
487 City Utilities	UTILITIES - W&S	203	01/26/2024	229.53
495 UNITED SYSTEMS & SOFTWARE INC.	ITRON 1000W ENCODER 2 PORT/CONNECTORS	203	01/26/2024	15,830.63
502 Aviston Lumber Company	R-11 15" KRAFT FACED 155 SQ FT.	203	01/26/2024	77.41
502 Aviston Lumber Company	CONC. ANCHOR SCREW,2X4 PINE FIR #2, OSB	203	01/26/2024	124.26
522 Essenpreis Plumbing & Htg	WATTS T&O, WATTS SED.	203	01/26/2024	33.14
524 Fehrmann Garage Doors Inc	14' TSO1LS HEAVY DUTY COMMERCIAL, REPLACE CABLES	203	01/26/2024	1,550.00
542 JANSEN CHEVROLET CO INC	IL. SAFETY INSPECTION - TRUCK # 717	203	01/26/2024	61.00
542 JANSEN CHEVROLET CO INC	IL. SAFETY INSPECTION- TRUCK #12	203	01/26/2024	51.00
542 JANSEN CHEVROLET CO INC	IL. SAFETY INSPECTION - TRUCK # 22	203	01/26/2024	51.00
542 JANSEN CHEVROLET CO INC	IL. SAFETY INSPECTION -TRUCK # 49	203	01/26/2024	51.00
542 JANSEN CHEVROLET CO INC	IL. SAFETY INSPECTION -TRUCK # 6	203	01/26/2024	51.00
547 K&J DESIGN LLC	DUMP TRUCK DOOR DECALS	203	01/26/2024	75.00
560 McKay Auto Parts Inc.	SPIN ON FLUID FILTER, SW20 SYNBLEND	203	01/26/2024	49.34
563 Midwest Municipal Supply Inc	12" HYMAX COUPLING	203	01/26/2024	892.21
563 Midwest Municipal Supply Inc	12" HUMAX COUPLING	203	01/26/2024	892.21
567 O'Reilly Automotive Inc.	1 QTY WIPER BLADE, 1 QTY WIPER BLADE	203	01/26/2024	40.78
578 Schulte Supply Inc	12"X30" REPAIR CLAMP	203	01/26/2024	1,232.44
578 Schulte Supply Inc	8"X15" REPAIR CLAMP	203	01/26/2024	345.18
578 Schulte Supply Inc	12"X15" REPAIR CLAMP	203	01/26/2024	566.60
578 Schulte Supply Inc	AERVO BLUE MARKING PAINT	203	01/26/2024	129.84
578 Schulte Supply Inc	6"X15" REPAIR CLAMP	203	01/26/2024	284.00
580 Spaeth Welding Inc	REPAIR STEEL TANK , SAND, PAINT, PRIME	203	01/26/2024	716.00
581 Steve Schmitt Inc	TRUCK # 708 - DOOR HINGE SPRING REPAIR	203	01/26/2024	353.15
596 Wilke Truck Service Inc.	FAI SAND- TICKET #94562 -14.05 TON , \$14.25 P/T	203	01/26/2024	49.16
			TOTAL	23,818.79
487 City Utilities	UTILITIES - PW	301	01/26/2024	165.91
558 Mastercard	TRAINING - DOUGHNUTS - MOTOR MART	301	01/26/2024	27.06
595 WELLS FARGO VENDOR FIN SERV	RICOH COPIER IM C3500	301	01/26/2024	211.15
			TOTAL	404.12
547 K&J DESIGN LLC	DUMP TRUCK DOOR DECALS	303	01/26/2024	75.00
			TOTAL	75.00
487 City Utilities	UTILITIES - WRF	304	01/26/2024	25.00
487 City Utilities	UTILITIES - WRF	304	01/26/2024	25.00
487 City Utilities	UTILITIES - WRF	304	01/26/2024	25.00
487 City Utilities	UTILITIES - WRF	304	01/26/2024	25.00
487 City Utilities	UTILITIES - WRF	304	01/26/2024	61.55
487 City Utilities	UTILITIES - WRF	304	01/26/2024	61.55
487 City Utilities	UTILITIES - WRF	304	01/26/2024	170.70
526 Ferrellgas	PROPANE FOR HWRF	304	01/26/2024	489.06
530 GEBKE BROS OUTDOOR PWR EQUIP. INC.	WRF - TRUCK # 51 INSPECTION	304	01/26/2024	39.00
531 Hawkins Inc	DEMURRAGE	304	01/26/2024	40.00
554 London Shoe Shop	SAFETY BOOTS - BRIAN BERBERICH	304	01/26/2024	200.00
584 Teklab Inc	HWRF ANNUAL SAMPLING	304	01/26/2024	1,585.00
584 Teklab Inc	HWRF ANNUAL SAMPLING	304	01/26/2024	1,515.50
			TOTAL	4,262.36
487 City Utilities	UTILITIES - WRF	305	01/26/2024	25.00
549 KIMBERLY A COLE	REVIEW, PROJECT MGMT., DATA MGMT, TEMPLATE REV.	305	01/26/2024	8,025.97
			TOTAL	8,050.97
487 City Utilities	UTILITIES - 1122 BROADWAY	401	01/26/2024	504.63
490 HFS Bureau of Fiscal Operations- GEMT	PROCEDURE CODE A0427&A0429(2022) QTR 3&4	401	01/26/2024	29,576.75
490 HFS Bureau of Fiscal Operations- GEMT	PROCEDURE CODE A0427&A0429 (2023) QTR 1&2	401	01/26/2024	57,500.33
496 Airgas USA LLC	OXYGEN	401	01/26/2024	249.55
496 Airgas USA LLC	OXYGEN	401	01/26/2024	27.04
507 Bound Tree Medical LLC	EMS SUPPLIES	401	01/26/2024	1,073.36
536 HSHS Medical Group Inc	DRUG SCREEN, CHAIN OF CUSTODY - L SCHUHARDT	401	01/26/2024	37.00
536 HSHS Medical Group Inc	PHYSICAL, PRE-PLACEMENT L SCHUHARDT	401	01/26/2024	60.00
552 LARRY HOLT	OVERPAYMENT EMS- ACCOUNT PAID IN FULL	401	01/26/2024	150.00
553 Leon Uniform Company Inc	1 QTY SHIELD FLEXTech 1/4 ZIP/EMS LOGO	401	01/26/2024	109.00
553 Leon Uniform Company Inc	EMS UNIFORMS	401	01/26/2024	1,912.00
553 Leon Uniform Company Inc	2 QTY WMNS STRYKE PANTS	401	01/26/2024	175.00
558 Mastercard	FLAG DESK INC	401	01/26/2024	350.20
562 MICK'S GARAGE INC.	AMBULANCE INSPECTION #1542	401	01/26/2024	39.00
577 NORTH CENTRAL EMS CORPORATION	1 QTY STRYKE EMS PANTS	401	01/26/2024	75.98
590 United Health Care Medicare Solutions	AMBULANCE OVERPAYMENT - CHARLEEN A DOWNS	401	01/26/2024	305.89
			TOTAL	92,145.73
487 City Utilities	OUTDOOR POOL- UTILITIES	503	01/26/2024	100.63
			TOTAL	100.63
487 City Utilities	CEMETERY- UTILITIES	715	01/26/2024	35.29
487 City Utilities	CEMETERY CHAPEL- UTILITIES	715	01/26/2024	25.00
556 Luijohan Flooring Inc	CEMETERY- BREAKROOM PART	715	01/26/2024	371.80
592 Village Locksmith	CEMETERY SHED- SCHLAGE KEYPAD ENTRY	715	01/26/2024	471.96
			TOTAL	904.05
			GRAND TOTAL	810,627.12